

GASPARDO

MASCHIO GASPARDO S.p.A.

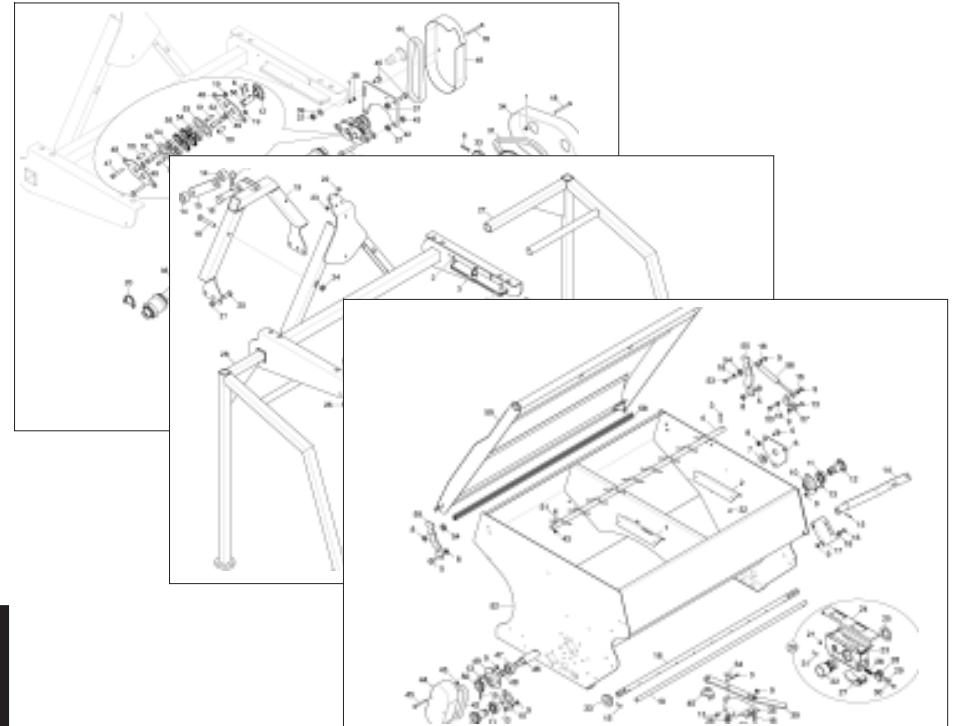

VITIGREEN

Cod: G19530711 2010-04

- *) Valido per Paesi UE
- *) Valid for EU member countries
- *) Valable dans les Pays UE
- *) Gilt für EU-Mitgliedsländer
- *) Válido para Países UE

- IT** PARTI DI RICAMBIO
- EN** SPARE PARTS
- DE** ERSATZTEILE
- FR** PIÈCES DÉTACHÉES
- ES** PIEZAS DE REPUESTO

PARTI DI RICAMBIO**SPARE PARTS****ERSATZTEILE****PIECES DÉTACHÉES****RESPUESTOS**

Le ordinazioni delle parti di ricambio vanno fatte presso i nostri concessionari di zona e devono essere sempre corredate dalle seguenti indicazioni:

- **Tipo, modello e numero di matricola dell'attrezzatura.** Tali dati sono stampigliati nell'apposita targhetta di cui è dotata ogni attrezzatura.

- **Numero di codice della parte richiesta** rilevabile dal catalogo ricambi.

- **Descrizione del particolare e quantità richiesta.**

- **Numero della tavola.**

- **Mezzo di trasporto.** Nel caso questa voce non sia specificata, la Ditta Costruttrice, pur dedicando a questo servizio una particolare cura, non risponde di eventuali ritardi di spedizione dovuti a cause di forza maggiore.

Le spese di trasporto si intendono sempre a carico del destinatario. La merce viaggia a rischio e pericolo del committente anche se venduta franco destino.

NOTA: Il termine **(Dx) Destro** o **(Sx) Sinistro** della macchina o di parti di essa, è inteso guardando la macchina dalla parte posteriore. Le eccezioni saranno indicate.

Orders must be transmitted through our area dealers and should always include the following indications:

- **Type, model and serial number of the machine.** *These data are punched on the data plate with which every implement is equipped.*

- **Code number of the required spare part.** *This will be found in the spare parts catalogue.*

- **Description of the part and required quantity.**

- **Table number.**

- **Means of dispatch.** *If this item is not indicated, the Manufacturer, while dedicating particular care to this service, shall not be held responsible for delays in delivery caused by cases of force majeure.*

Transport expenses shall always be at the consignee's charge. The goods travel at the purchaser's risk and peril even when sold ex destination.

NOTE: *The symbols (Dx) right and (Sx) left, concerning the machine or single parts of it, are referred, as in the figure, to a rear view of them. Exceptions will be indicated.*

Die Bestellungen müssen bei unseren Gebietshändler aufgegeben werden. Bei der Bestellung sind stets die folgenden Angaben zu machen:

- **Typ, Modell und Serien-Nummer des Geräts.** Diese Daten stehen auf dem Typenschild, mit dem jedes Gerät versehen ist.

- **Artikel Nr. der erforderlichen Ersatzteile.** Diese stehen im Ersatzteil-Katalog.

- **Beschreibung des Ersatzteils und die erforderliche Stückzahl.**

- **Tafelnummer.**

- **Versandmittel.** Wenn dieser Punkt nicht spezifiziert wird, haftet die Herstellerfirma nicht für etwaigen Lieferverzug aufgrund höherer Gewalt, auch wenn er diesen Service besonders aufmerksam abwickelt. Die Frachtkosten gehen dagegen immer zu Lasten des Empfängers. Die Ware reist auf Gefahr und Risiko des Auftraggebers, auch wenn frei Haus Verkauft vereinbart worden ist.

N.B.: Die Merkzeichen **(Dx) rechts** und **(Sx) links** betreffen eine rückwärtige Aussicht der Maschine oder Teile von ihr (siehe Bild). Ausnahmen werden gezeigt.

Les ordres doivent être effectués auprès de nos concessionaires de zone en précisant les indications suivantes:

- **Type, modèle et numéro de série de la machine.** *Ces données sont gravées sur la plaque d'identification de chaque outil.*

- **Numéro de code de la pièce détachée** indiqué sur le catalogue des pièces détachées.

- **Description de la pièce et quantité requise.**

- **Numéro de plan.**

- **Moyen d'expédition.** *Si cette rubrique n'est pas indiquée, le Constructeur, bien que soucieux de ce service, ne répond pas des retards d'expédition pour des causes de force majeure.*

Les frais de transport sont toujours à la charge du destinataire. La marchandise voyage aux risques et périls de l'acheteur même si vendue franco de port.

N.B.: *Les références (Dx) droit et (Sx) gauche de la machine ou des parties de la même, est entendue, comme de la figure, en regardant la machine de derriere dans le sens de marche.*

Los pedidos han de efectuarse en nuestros consesionarios de zona y deben incluir siempre las siguientes indicaciones:

- **Tipo, modelo y número de matricula del equipo.** Dichos datos están impresos en la relativa placa presente en el equipo.

- **Número de código de la parte requerida** presente en el catálogo respuestas.

- **Descripción de la pieza y cantidad requerida.**

- **Numero de ilustración.**

- **Medio de transporte.** En caso que este ítem no esté especificado, el Fabricante, aún prestando la debidas consideraciones para este aspecto, no responde por eventuales retardos de env'o debidos a causas de fuerza mayor. Los gastos de transporte se consideran siempre a cargo del destinatario. La mercadería viaja bajo riesgo y peligro del comprador, incluso cuando se vende franco destino.

N.B.: La refencia **(Dx) derecha** o **(Sx) izquierda** de la máquina o de sus componentes, se entiende, como en la figura, mirando la máquina por la parte trasera. Se indicarán las excepciones.

<i>Nr. Tav.</i>	<i>Descrizione - Description</i>	<i>Pag.</i>
TAV. 010	Tramoggia	4
TAV. 020	Teliao	6
TAV. 030	Trasmissione	8

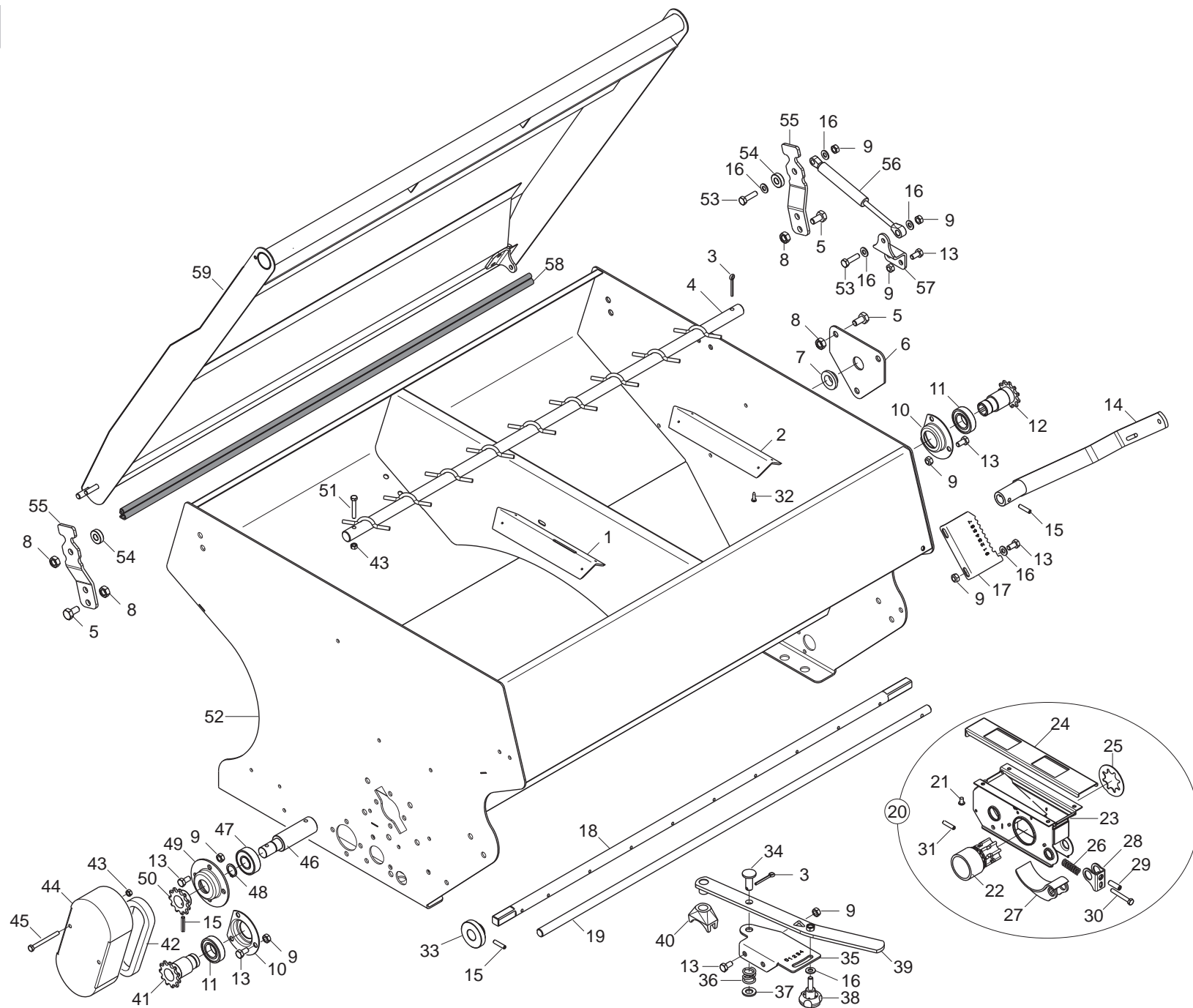

TELAIO ANTERIORE

TAV. 010

Pos.	Cod.	Descrizione	Description	Description	Benennung	Descripcion
1	17521430	DIFFUSORE SEME CENTRALE COMPL				
2	17521420	DIFFUSORE SEME COMPL				
3	F02200162	COPIGLIA 3 X20 1336 ZN	SPLINT PIN 3 X20 1336 GALVAN.	GOUPILLE 3 X20 1336 ZN	SPLINT 3 X20 1336 ZN	PASADOR 3 X20 1336 ZN
4	17521290	ALBERO MESCOLO VITIGREEN				
5	F01020470	VITE 10X20 5739 8.G ZN	BOLT 10X20 5739 8.G GALVANIZED	VIS 10X20 5739 8.G ZN	SCHRAUBE 10X20 5739 8.G ZN	TORNILLO 10X20 5739 8.G ZN
6	16910910	CHIUSURA PER ALBERO MESCOLO	MIXER SHAFT CLOSURE	FERMETURE ARBRE MELANGEUR	VERSCHLUSS MISCHERWELLE	CIERRE EJE MEZCLADOR
7	19004420	BOCCOLA SUPP.ASSE AGITATORE	UPPER STIRRER SHAFT BUSH	DOUILLE SUPP. AXE AGITATEUR	OBERE BUCHSE R_HRWELLENACHSE	MANGUITO SOP.EJE AGITADOR
8	F01220233	DADO TRISTOP M10	NUT TRISTOP M10	ECROU TRISTOP M10	MUTTER TRISTOP M10	TUERCA TRISTOP M10
9	F01220222	DADO TRISTOP M 8	NUT- TRISTOP M 8	ECROU TRISTOP M 8	MUTTER TRISTOP M 8	TUERCA TRISTOP M 8
10	22230086	SUPPORTO CUSCINETTO TAGLIATO	CUT BEARING SUPPORT	SUPPORT PALIER COUPE	HALTERUNG LAGER MIT SCHNITT	SOPORTE COJINETE CORTADO
11	F04010135	CUSCINETTO 6005 2RS	BEARING 6005 2RS	ROULEMENT 6005 2RS	LAGER 6005 2RS	COJINETE 6005 2RS
12	16930330	PIGNONE DISTRIBUZIONE SEME	GALVAN. PINION DISTR.	PIGNON DISTRIB. ZN	RITZEL VERTEIL. ZN	PINION DISTRIB. ZN
13	F01020432	VITE 8 X16 5739 8.G ZN	BOLT 8X16 5739 8.G GALVANIZED	VIS 8X16 5739 8.G ZN	SCHRAUBE 8X16 5739 8.G ZN	TORNILLO 8X16 5739 8.G ZN
14	16920460	LEVA REGOLAZIONE TASTATORI	FEELER ADJUSTING LEVER	LEVIER DE REGLAGE DES TATEURS	TASTERREGULIERHEBEL	PALANCA DE REGULAC. DE PALPAD
15	F02100110	SPINA EL.6 X26 DIN 1481	PIN EL. 6 X26 DIN 1481	FICHE EL.6 X26 DIN 1481	SPANNSTIFT 6 X26 DIN 1481	CLAVIJA EL.6 X26 DIN 1481
16	F01410051	RONDELLA D8 UNI 6592 ZN	WASHER D8 UNI 6592 GALVANIZED	RONDELLE D8 UNI 6592 ZN	UNTERLEGSSCHEIBE D8 UNI 6592 ZN	ARANDELA D8 UNI 6592 ZN
17	16920360	SUPPORTO REGOLAZ. TASTATORI ZN	REGULATION SUPPORT	SUPPORT REGLAGE	EINSTELLERHALTERUNG	SOPORTE REGULACIÉN
18	17521310	ASSE DISTRIBUZIONE ZN				
19	17521300	ASSE TASTATORI ZN VITIGREEN				
20	16920270	DISTRIBUTORE S COMPL.	COMPL. DISTRIBUTOR S	DISTRIBUTEUR S COMPL.	STREUER S KOMPL.	DISTRIBUIDOR S COMPL.
21	F02250148	RIVETTO STRAPPO 6X12 ALL	PULL RIVET 6X12 ALL	RIVET A RUPTURE 6X12 ALU	REISSNIETE 6X12 ALL	REMACHE DESGAR. 6X12 ALL
22	19004371	RULLO DISTRIBUTORE SEME	SEED DISTRIBUTION ROLLER	ROULEAU DISTRIBUTEUR GRAINES	SAATGUTSTREUWALZE	RODILLO DISTRIBUIDOR SEMILLAS
23	16930190	SCATOLA DISTRIBUZIONE S	S DISTRIBUTION BOX	BOITE DE DISTRIBUTION S	STREUUNGSKASTEN S	CAJA DE DISTRIBUCION S
24	16930200	LEVA APERTURA	OPENING LEVER	LEVIER OUVERTURE	HEBEL STREUER	PALANCA MOVIL
25	16930010	RONDELLA SCORR.RULLO SEME	SLIDING SEED ROLLER WASHER	RONDELLE COULISSANTE ROULEAU G	UNTERLEGSSCHEIBE GLEITUNG SAMEN	ARANDELA DESLIZ. RODILLO SEMIL
26	18904010	MOLLA SPINTA TASTATORE	FEELER PIN PUSH SPRING	RESSORT POUSSEE PALPEUR	FEDER SCHUB ABTASTER	MUELLE EMPUJE PALPADOR
27	19004391	TASTATORE	FEELER PIN	T-TEUR	ABTASTER	PALPADOR
28	16920050	SUPPORTO TASTATORE	FEELER POINT SUPPORT	SUPPORT TATEUR	HALTERUNG ABTASTER	SOPORTE PALPADOR
29	F01050101	GRANO 8X25 5927 ZN	GRUB-SCREW 8 X25 5927	GOUJON 8 X25 5927	STIFT 8 X25 UNI 5927	TORNILLO SIN CABEZA 8 X25 5927
30	F01020041	VITE 6 X45 5737 8.G ZN	BOLT 6 X45 5737 8.G GALVANIZED	VIS 6 X45 5737 8.G ZN	SCHRAUBE 6 X45 5737 8.G ZN	TORNILLO 6 X45 5737 8.G ZN
31	F02100087	SPINA EL.5 X30 DIN 1481	PIN EL. 5 X30 DIN 1481	FICHE EL. 5 X30 DIN 1481	SPANNSTIFT 5 X30 DIN 1481	CLAVIJA EL.5 X30 DIN 1481
32	F01070073	VITE 4,2X9,5 DIN 7981	BOLT 4-2X 9-5 DIN 7981	VIS 4-2X 9-5 DIN 7981	SCHRAUBE 4-2X 9,5 DIN 7981	TORNILLO 4-2X 9-5 DIN 7981
33	16920550	BOCCOLA ALBERO DISTRIBUTORE	BUSHING DISTRIBUTION AXLE	BOITE ARBRE DE DISTRIBUTION	BUCHSE ANTRIEBSWELLE	MANGUITO EJE DISTRIBUIDOR
34	16920520	PERNO MOLLA DI COMPRESSIONE	COMPRESSION SPRING PIN	PIVOT RESSORT DE COMPRESSION	BOLZEN DRUCKFEDER	PERNO MUELLE DE COMPRESIÉN
35	17521230	SUPPORTO LEVA REGOLAZIONE ZN				
36	18904000	MOLLA COMPRESSIONE DISTRIB.	DISTRIB. COMPRESSION SPRING	RESSORT COMPRESSION DISTRIB.	DRUCKFEDER STREUER	MUELLE COMPRESIÉN DISTRIB.
37	F01410076	RONDELLA D12 UNI 6592 ZN	WASHER D12 UNI 6592 ZN	RONDELLE D12 UNI 6592 ZN	UNTERLEGSSCHEIBE D12 UNI 6592 Z	ARANDELA D12 UNI 6592 ZN
38	F06220019	VOLANTINO 4 LOBI D.40-M 8X25	4-LOBE HANDWHEEL M8X25	VOLANT 4 LOBES M8X25	HANDRAD 4 BUCKEL M8X25	VOLANTE 4 LOBI M8X25
39	17521250	LEVA APERTURA DOSATORI				
40	16920540	BLOCCO GUIDA ALBERO DISTRIB.	DISTRIB. SHAFT GUIDE BLOCK	BLOCAGE GUIDE ARBRE DISTRIBUTI	F_HRUNGSBLOCK VERTEILERWELLE	BLOQUE GUIA ARBOL DISTRIB.
41	17530810	PIGNONE Z11 Q.16,4 ZN				
42	F06080012	SPEZ.CAT.1/2 ISO 083 30MAGLIE	CUTDAWN CHAIN 1/2 ISO 30LINKS			
43	F01200232	DADO 6 5588 6.8 ZN	NUT 6 UNI 5588 6.8 GALVANIZED	ECROU 6 UNI 5588 6.8 ZN	MUTTER 6 UNI 5588 6.8 ZN	TUERCA 6 UNI 5588 6.8 ZN
44	17530710	CARTER TRASMISSIONE AGITATORE				
45	F01020047	VITE 6 X70 5737 8.G ZN	BOLT 6 X70 5737 8.G GALVANIZED	VIS 6 X70 5737 8.G ZN	SCHRAUBE 6 X70 5737 8.G ZN	TORNILLO 6 X70 5737 8.G ZN
46	16930310	PERNO ROTAZ.ALBERO AGITAT.ZN	ROTATION PIVOT	PIVOT ROTATION	ZAPFEN DREHUNG	PERNO ROTACIÉN
47	F04010164	CUSCINETTO 6204 2RS	BEARING 6204 2RS	ROULEMENT 6204 2RS	LAGER 6204 2RS	COJINETE 6204 2RS
48	F02050609	ANELLO ARR.20 UNI 7435-75	STOP RING 20 UNI 7435-75	BAGUE ARRET 20 UNI 7435-75	RING 20 UNI 7435-75	ANILLO PARADA 20 UNI 7435-75
49	16242190	SUPPORTO CUSCINETTO	BEARING SUPPORT	SUPPORT PALIER	LAGERBSCHSE	SOPORTE COJINETE
50	16230040	PIGNONE Z-11 ZN	GEAR Z.11 GALVANIZED	PIGNON Z 11 ZN	RITZEL Z 11 ZN	PIÑÓN Z 11 ZN P
51	F01020040	VITE 6 X40 5737 8.G ZN	BOLT 6 X40 5737 8.G GALVANIZED	VIS 6 X40 5737 8.G ZN	SCHRAUBE 6 X40 5737 8.G ZN	TORNILLO 6 X40 5737 8.G ZN
52	17521220	TRAMOGGIA VITIGREEN 9 U				
53	F01020445	VITE 8 X30 5739 8.G ZN	BOLT 8X30 5739 8.G GALVANIZED	VIS 8X30 5739 8.G ZN	SCHRAUBE 8X30 5739 8.G ZN	TORNILLO 8X30 5739 8.G ZN
54	18801680	BOCCOLA 11 X25 X7,5 ZN	BUSHING 11X25X7,5 GALVA	BOITE 11X25X7,5 ZN	BSCHSE 11X25X7,5 ZN	CASQUILLO 11X25X7,5 ZN
55	16913600	STAFFA ROTAZIONE COPERCHIO ZN	ROTATION BRACKET	BRIDE DE ROTATION	ROTATIONB_GEL	ABRAZADERA DE ROTACIÉN
56	F02400011	MOLLA A GAS 400N	GAS SPRING 400 N	RESSORT A GAZ 400 N	GASFEDER 400 N	MUELLE DE GAS 400 N
57	16313680	ATTACCO STELO MOLLA ZN				
58	F03011141	GUARNIZIONE GOMMA				

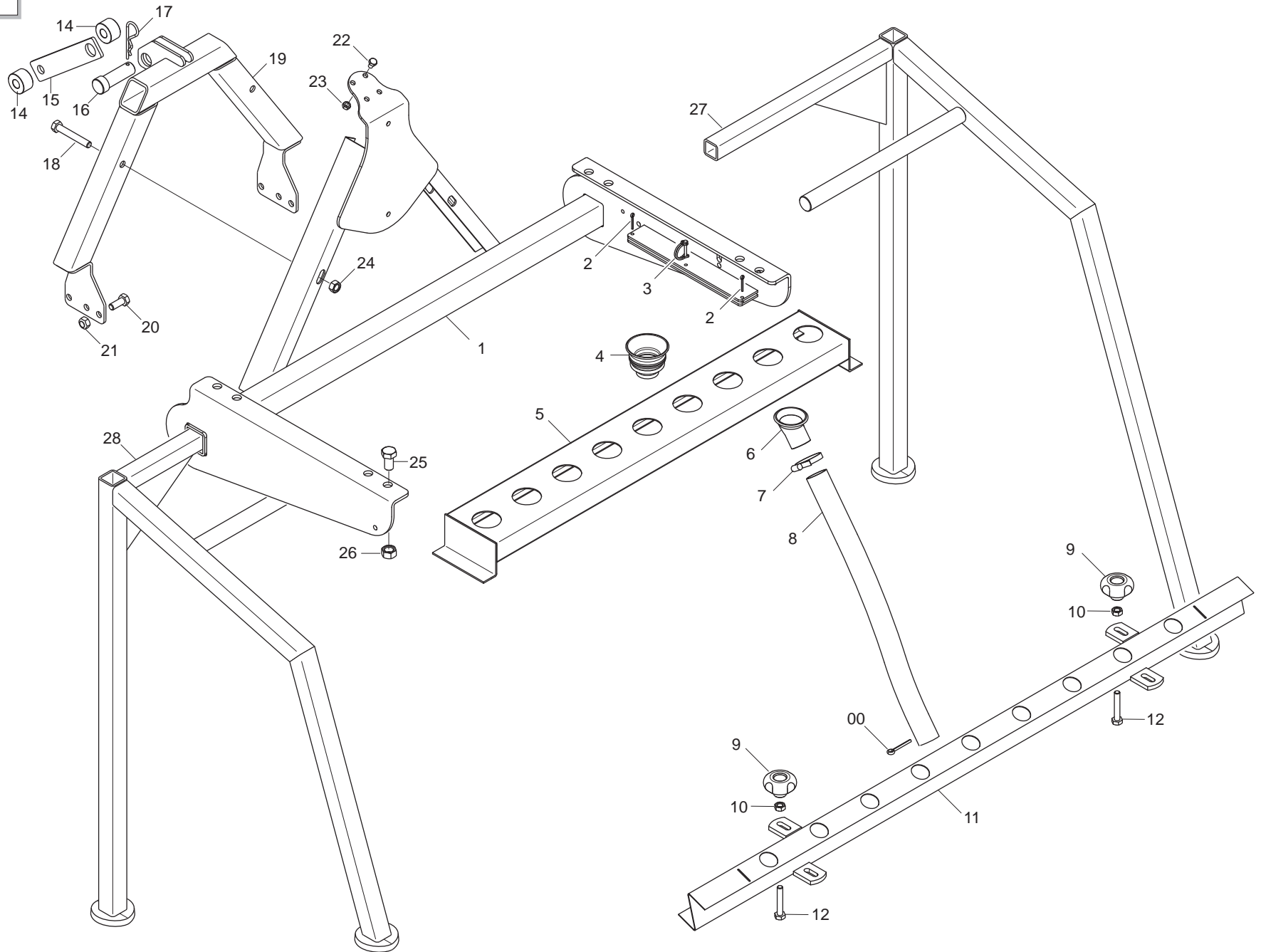

TELIAO POSTERIORE
TAV. 020

Pos.	Cod.	Descrizione	Description	Description	Benennung	Descripcion
1	17510380	TELAIO VITIGREEN				
2	F02200162	COPIGLIA 3 X20 1336 ZN	SPLIT PIN 3 X20 1336 GALVAN.	GOUPILLE 3 X20 1336 ZN	SPLINT 3 X20 1336 ZN	PASADOR 3 X20 1336 ZN
3	F02200452	SPINA A SCATTO D.4,4 B/80	SNAP PIN D.4-4 B/80	FICHE A DETENTE D. 4-4 B/80	EINRASTSTIFT D 4-4 B/80	CLAVIJA DE MUELLE D.4-4 B/80
4	19003070	CUFFIA SUPERIORE	TELESCOPIC TUBE SUPPORT	PROTECTEUR SUPERIEUR	OB. KASTEN	ENVOLTURA SUPERIOR
5	17521270	BUSSOLIERA VITIGREEN				
6	19004360	IMBUTO DISCESA SEME-CONCIME	SEED-FERTILIZER COLLECTOR	ENTONNOIR CHUTE GRAINE-ENGRAIS	TRICHTER D. NGER-SAMENFALL	EMBUDO CAIDA SEMILLAS-ABONO
7	F02300020	FASCETTA STRING 32/50	STRING FASTENING STRAPS 32/50	COLLIER DE SERRAGE 32/50	ROHRSCHELLE 32/50	ABRAZADERA APRET. 32/50
8	F03100530	TUBO EOLO PU-P D.32	SATURNO PIPE PU-P D.32	TUBE SATURNO PU-P D.32	ROHR SATURNO PU-P D.32	TUBO SATURNO PU-P D.32
9	F06220022	VOLANTINO 4LOBI D.60-M10 FEM.				
10	F01200270	DADO 10 5588 6.8 ZN	SCREW 10 UNI 5588 6.8 GALVANIZ	ECROU 10 UNI 5588 6.8 ZN	MUTTER 10 UNI 5588 6.8 ZN	TUERCA 10 UNI 5588 6.8 ZN
11	17521351	BUSSOLIERA 9 U 1300-1500				
12	F01020487	VITE 10X60 5739 8.G ZN	SCREW 10X60 5739 8.G GALVAN.	VIS 10X60 5739 8.G ZN	SCHRAUBE 10X60 5739 8.G ZN	TORNILLO 10X60 5739 8.G ZN
13	F02200230	COPIGLIA 5 X50 1336 ZN	SPLIT PIN 5 X50 1336 GALVAN.	GOUPILLE 5 X50 1336 ZN	SPLINT 5 X50 1336 ZN	PASADOR 5 X50 1336 ZN
14	17510580	BOCCOLA 17X40X24 PLA				
15	17510570	TIRANTE 3°PUNTO				
16	16910310	SPINA 25X62 ZN	PIN ZN	GOUPILLE ZN	BOLZENSTIFT ZN	PASADOR ZN
17	F02200374	COPIGLIA R 4X82 ZN B/108	SPLIT PIN R 4X82 GALVAN. B/108	GOUPILLE R 4X82 ZN B/108	SPLINT R 4X82 ZN B/108	PASADOR R 4X82 ZN B/108
18	F01020166	VITE 12X80 5737 8.G ZN	BOLT 12X80 5737 8.G GALVANIZED	VIS 12X80 5737 8.G ZN	SCHRAUBE 12X80 5737 8.G ZN	TORNILLO 12X80 5737 8.G ZN
19	17510300	TRIANGOLO ERPICE				
20	F01020510	VITE 12X30 5739 8.G ZN	BOLT 12X30 5739 8.G GALVANIZED	VIS 12X30 5739 8.G ZN	SCHRAUBE 12X30 5739 8.G ZN	TORNILLO 12X30 5739 8.G ZN
21	F01220244	DADO TRISTOP M12	NUT- TRISTOP M12	ECROU TRISTOP M12	MUTTER TRISTOP M12	TUERCA TRISTOP M12
22	F01020436	VITE 8 X20 5739 8.G ZN	BOLT 8X20 5739 8.G GALVANIZED	VIS 8X20 5739 8.G ZN	SCHRAUBE 8X20 5739 8.G ZN	TORNILLO 8X20 5739 8.G ZN
23	F01220222	DADO TRISTOP M 8	NUT- TRISTOP M 8	ECROU TRISTOP M 8	MUTTER TRISTOP M 8	TUERCA TRISTOP M 8
24	F01200293	DADO 12 5588 6.8 ZN	NUT 12 UNI 5588 6.8 GALVANIZED	ECROU 12 UNI 5588 6.8 ZN	MUTTER 12 UNI 5588 6.8 ZN	TUERCA 12 UNI 5588 6.8 ZN
25	F01020562	VITE 16X30 5739 8.G ZN	SCREW 16X30 5739 8.G GALVANIZ	VIS 16X30 5739 8.G ZN	SCHRAUBE 16X30 5737 8.G ZN	TORNILLO 16X30 5739 8.G ZN
26	F01200321	DADO M16X 2 U5588 6.8 ZG	NUT M16X 2 U5588 6.8 ZG	ECROU M16X 2 U5588 6.8 ZG	MUTTER M16X 2 U5588 6.8 ZG	TUERCA M16X 2 U5588 6.8 ZG
27	17510470	SUPPORTO TRAMOGGIA DX				
28	17510540	SUPPORTO TRAMOGGIA SX				

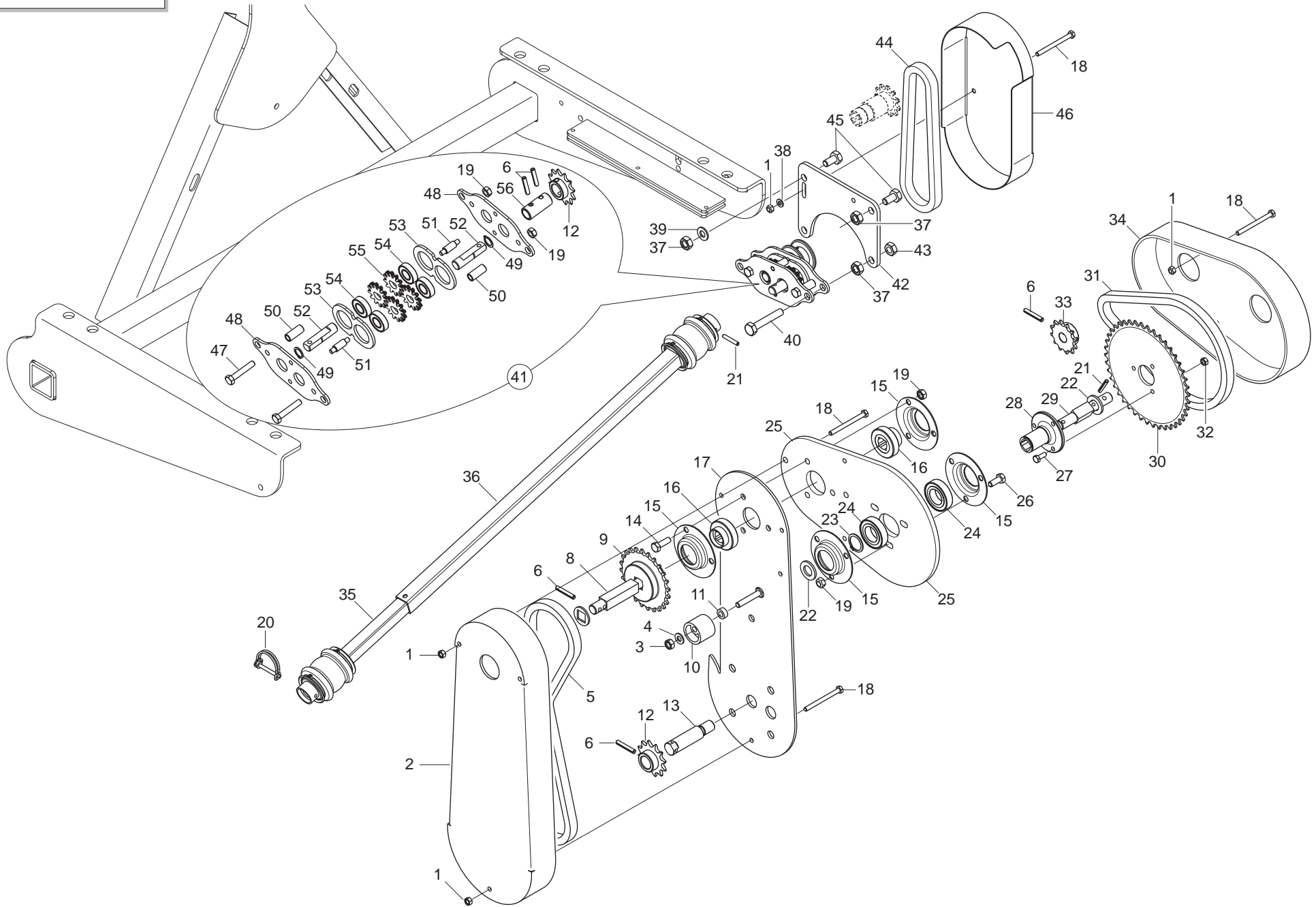

IMPIANTO OLEODINAMICO TELAIO POSTERIORE

TAV. 030

Pos.	Cod.	Descrizione	Description	Description	Benennung	Descripcion
1	F01200232	DADO 6 5588 6.8 ZN	NUT 6 UNI 5588 6.8 GALVANIZED	ECROU 6 UNI 5588 6.8 ZN	MUTTER 6 UNI 5588 6.8 ZN	TUERCA 6 UNI 5588 6.8 ZN
2	17530770	CARTER TRASMISSIONE RULLO				
3	F01230034	DADO AUTOB.NOR.8 ZN	NORMAL SELF-LOCKING NUT 8 GALV	ECROU AUTOB. NOR. 8 ZN	SELBSTSP. MUTTER NOR. 8 ZN	TUERCA AUTOB. NOR. 8 ZN
4	F01410051	RONDELLA D8 UNI 6592 ZN	WASHER D8 UNI 6592 GALVANIZED	RONDELLE D8 UNI 6592 ZN	UNTERLEGSSCHEIBE D8 UNI 6592 ZN	ARANDELA D8 UNI 6592 ZN
5	F06080037	SPEZ.CAT.1/2 ISO 083 73MAGLIE	CUT-DOWN CHAIN .1/2 ISO 083 73	TR. CH.1/2 ISO 083 73 MAILLES	KETTENZNGE 1/2 ISO 083 73 GL	TRECHO CADENA 1/2 ISO 083 73 E
6	F02100118	SPINA EL.6 X36 DIN 1481	PIN EL. 6 X36 DIN 1481	FICHE EL. 6 X36 DIN 1481	SPANNSTIFT 6 X36 DIN 1481	CLAVIJA EL.6 X36 DIN 1481
7	18701650	RONDELLA FORO QUADRO ZN	WASHER 16,5X30X2,5 ZN	RONDELLE 16,5X30X2,5 ZN	UNTERLEGSSCHEIBE 16,5X30X2,5 ZN	ARANDELA 16,5X30X2,5 ZN
8	17530860	PERNO TRASMISSIONE RULLO ZN				
9	20900041	PIGNONE Z24 1/2X3/16 Q.16,4 ZN	GEAR 1/2 Z-24 F.Q. HL	ENGRENAGE 1/2 Z-24 TROUS CARRE	ZAHNRAD 1/2 Z-24 F.Q. HL	ENGRANAJE 1/2 Z-24 F.Q. HL
10	66248207	TENDICATENA SPAND. SP-520	CHAIN TENSIONER	TENDEUR DE CHAINE EPAND. ENGR.	KETTENSANNER DsNGERSTR. SP-52	SENSOR DE CADENA ABON. SP-520
11	20980050	BOCCOLA 15X7X8,5 ZN	BUSHING 15X7X8,5 ZN	BOITE 15X7X8-5 ZN	BsCHSE 15X7X8-5 ZN	CASQUILLO 15X7X8-5 ZN
12	16230040	PIGNONE Z-11 ZN	GEAR Z.11 GALVANIZED	PIGNON Z 11 ZN	RITZEL Z 11 ZN	PI¼N Z 11 ZN P
13	17530460	ASSE CORONA ENCODER	ENCODER SHAFT+B474 LOAD RING	AXE COURONNE ENCODEUR	ACHSE CORONA ENCODER	EJE CORONA ENCODER
14	F01020440	VITE 8 X25 5739 8.G ZN	BOLT 8X25 5739 8.G GALVANIZED	VIS 8X25 5739 8.G ZN	SCHRAUBE 8X25 5739 8.G ZN	TORNILLO 8X25 5739 8.G ZN
15	22230094	SUPPORTO CUSCINETTO	BEARING SUPPORT	SUPPORT PALIER	LAGERBsCHSE	SOPORTE COJINETE
16	14830390	CUSCINETTO FORO QUADRO	SQUARE-HOLED BEARING	ROULEMENT AL+SAGE CARR+	VIERKANTLAGER	COJINETE ORIFICIO CUADRADO
17	17530760	PIASTRA SUPPORTO TRASMISS.				
18	F01020047	VITE 6 X70 5737 8.G ZN	BOLT 6 X70 5737 8.G GALVANIZED	VIS 6 X70 5737 8.G ZN	SCHRAUBE 6 X70 5737 8.G ZN	TORNILLO 6 X70 5737 8.G ZN
19	F01220222	DADO TRISTOP M 8	NUT- TRISTOP M 8	ECROU TRISTOP M 8	MUTTER TRISTOP M 8	TUERCA TRISTOP M 8
20	F02200595	SPINOTTO X INGRANAGGIO	PIN	BROCHE	BOLZEN	CLAVIJA
21	F02100087	SPINA EL.5 X30 DIN 1481	PIN EL. 5 X30 DIN 1481	FICHE EL. 5 X30 DIN 1481	SPANNSTIFT 5 X30 DIN 1481	CLAVIJA EL.5 X30 DIN 1481
22	F01410100	RONDELLA D16 UNI 6592 ZN	WASHER D16 UNI 6592 ZN	RONDELLE D16 UNI 6592 ZN	UNTERLEGSSCHEIBE D16 UNI 6592 Z	ARANDELA D16 UNI 6592 ZN
23	F02050613	ANELLO ARR.25 UNI 7435-75	STOP RING 25 UNI 7435-75	BAGUE DE SERRAGE 25 UNI 7435-7	DRAHTSPRENGRING 25 UNI 7435-75	ANILLO PARADA 25 UNI 7435-75
24	F04010135	CUSCINETTO 6005 2RS	BEARING 6005 2RS	ROULEMENT 6005 2RS	LAGER 6005 2RS	COJINETE 6005 2RS
25	17530890	PIASTRA RIDUZIONE TRASM.				
26	F01020436	VITE 8 X20 5739 8.G ZN	BOLT 8X20 5739 8.G GALVANIZED	VIS 8X20 5739 8.G ZN	SCHRAUBE 8X20 5739 8.G ZN	TORNILLO 8X20 5739 8.G ZN
27	F01020403	VITE 6 X16 5739 8.G ZN	BOLT 6X16 5739 8.G GALVANIZED	VIS 6X16 5739 8.G ZN	SCHRAUBE 6X16 5739 8.G ZN	TORNILLO 6X16 5739 8.G ZN
28	17530870	FLANGIA CORONA ZN				
29	17530880	PERNO TRASM.RIDUZIONE ZN				
30	20890128	CORONA Z-42 SP	RING GEAR Z-42 SP	COURONNE Z-42 SP	KRANZ Z-42 SP	CORONA Z-42 SP
31	F06080128	SP.CAT.1/2-3/16 53MAGLIE				
32	F01220211	DADO TRISTOP M 6	NUT- TRISTOP M 6	ECROU TRISTOP M 6	MUTTER TRISTOP M 6	TUERCA TRISTOP M 6
33	20860088	INGRANAGGIO 1/2 Z-12 F.T.	GEAR 1/2 Z-12 F.T.	ENGRENAGE 1/2 Z-12 TROUS RONDS	ZAHNRAD 1/2 Z-12 F.T.	ENGRANAJE 1/2 Z-12 F.T.
34	17530920	CARTER RIDUZIONE TRASM.				
35	16034560	GIUNTO Q.20 L.1000 COMPL				
36	16034540	GIUNTO Q.25 L.1000 COMPL				
37	F01200270	DADO 10 5588 6.8 ZN	SCREW 10 UNI 5588 6.8 GALVANIZ	ECROU 10 UNI 5588 6.8 ZN	MUTTER 10 UNI 5588 6.8 ZN	TUERCA 10 UNI 5588 6.8 ZN
38	F01410037	RONDELLA D6 UNI 6592 ZN	WASHER D6 UNI 6592 GALVANIZED	RONDELLE D6 UNI 6592 ZN	UNTERLEGSSCHEIBE D6 UNI 6592 ZN	ARANDELA D6 UNI 6592 ZN
39	F01410062	ROS.M10 10,5X 18X 2 U6592 ZG				
40	F01020118	VITE 10X60 5737 8.G ZN	BOLT 10X60 5737 8.G GALVANIZED	VIS 10X60 5737 8.G ZN	SCHRAUBE 10X60 5737 8.G ZN	TORNILLO 10X60 5737 8.G ZN
41	17530740	INVERSIONE TRASMISSIONE COMPL				
42	17510390	PIASTRA ATTACCO INVERSIONE				
43	F01220233	DADO TRISTOP M10	NUT TRISTOP M10	ECROU TRISTOP M10	MUTTER TRISTOP M10	TUERCA TRISTOP M10
44	F06080009	SP.CAT.1/2-3/16 41MAGLIE				
45	F01020470	VITE 10X20 5739 8.G ZN	BOLT 10X20 5739 8.G GALVANIZED	VIS 10X20 5739 8.G ZN	SCHRAUBE 10X20 5739 8.G ZN	TORNILLO 10X20 5739 8.G ZN
46	17530750	CARTER INVERSIONE TRASMISS.				
47	F01020070	VITE 8 X45 5737 8.G ZN	BOLT 8 X45 5737 8.G GALVANIZED	VIS 8 X45 5737 8.G ZN	SCHRAUBE 8 X45 5737 8.G ZN	TORNILLO 8 X45 5737 8.G ZN
48	17530720	FIANCO INVERSIONE TRASMISS.ZN				
49	F02050605	ANELLO ARR.15 UNI 7435-75	STOP RING 15 UNI 7435-75	BAGUE ARR.15 UNI 7435-75	RING 15 UNI 7435-75	ANILLO PARADA 15 UNI 7435-75
50	18802720	BOCCOLA 8,5X12X28 ZN				
51	16330510	DISTANZIALE GRUPPO INVERS. ZN				
52	16033841	PERNO GRUPPO INVERSIONE ZN				
53	16330500	FIANCO INTERNO RINVIO ZN				
54	F04010125	CUSCINETTO 6002 2RS1	BEARING 6002 2RS1	PALIER 6002 2RS1	LAGER 6002 2RS1	COJINETE 6002 2RS1
55	16033820	INGRANAGGIO M3 Z12 ZN				
56	17530730	DISTANZIALE TRASMISSIONE ZN				

**USATE SEMPRE RICAMBI ORIGINALI
ALWAYS USE ORIGINAL SPARE PARTS
IMMER DIE ORIGINAL-ERSATZTEILE VERWENDEN
EMPLOYEZ TOUJOURS LES PIECES DE RECHANGE ORIGINALES
UTILIZAR SIEMPRE REPUESTOS ORIGINALES**

GASPARDO

**Servizio Assistenza Tecnica - After Sales Service
Servizio Ricambi - Spare Parts Service
+39 0434 695410**

DEALER:



G19530711

MASCHIO **GASPARDO**

MASCHIO GASPARDO SpA

Sede legale e stabilimento produttivo

Via Marcello, 73 - 35011 Campodarsego (Padova) - Italy

Tel. +39 049 9289810

Fax +39 049 9289900

Email: info@maschio.com

www.maschionet.com

MASCHIO GASPARDO SpA

Stabilimento produttivo

Via Mussons, 7 - 33075

Morsano al Tagliamento (PN) - Italy

Tel. +39 0434 695410

Fax +39 0434 695425

Email: info@gaspardo.it

MASCHIO DEUTSCHLAND GMBH

Äußere Nürnberger Straße 5

D - 91177 Thalmässing

Deutschland

Tel. +49 (0) 9173 79000

Fax +49 (0) 9173 790079

MASCHIO FRANCE Sarl

1, Rue de Mérignan ZA

F - 45240 La Ferte St. Aubin

France

Tel. +33 (0) 2.38.64.12.12

Fax +33 (0) 2.38.64.66.79

MASCHIO IBERICA S.L.

Calle Cabernet, 10

Polígono Industrial Clot de Moja

Olerdola - 08734 Barcelona

Tel. +34 93.81.99.058

Fax +34 93.81.99.059

MASCHIO-GASPARDO USA Inc

120 North Scott Park Road

Eldridge, IA 52748 - USA

Ph. +1 563 2859937

Fax +1 563 2859938

e-mail: info@maschio.us

000 МАСКИО-ГАСПАРДО РУССИЯ

Улица Пушкина, 117 Б

404126 Волжский

Волгоградская область

Тел. +7 8443 525065

факс. +7 8443 525064

MASCHIO-GASPARDO ROMANIA S.R.L.

Strada Înfrățirii, F.N.

315100 Chisineu-Cris (Arad) - România

Tel. +40 257 307030

Fax +40 257 307040

e-mail: maschio@maschio.ro

MASCHIO MIDDLEEAST

P.O. Box 922388

Amman, 11192 Jordan

Tel. 962 605511384

Fax 962 6 5538398

e-mail: tahaeng@nets.com.jo

GASPARDO-MASCHIO TURCHIA

MASCHIO-GASPARDO CANADA Inc

MASCHIO-GASPARDO CINA

MASCHIO-GASPARDO POLAND

MASCHIO-GASPARDO UCRAINA

GASPARDO BIELORUSSIA

MASCHIO-GASPARDO KOREA