

# GASPARDO

MASCHIO GASPARDO S.p.A.

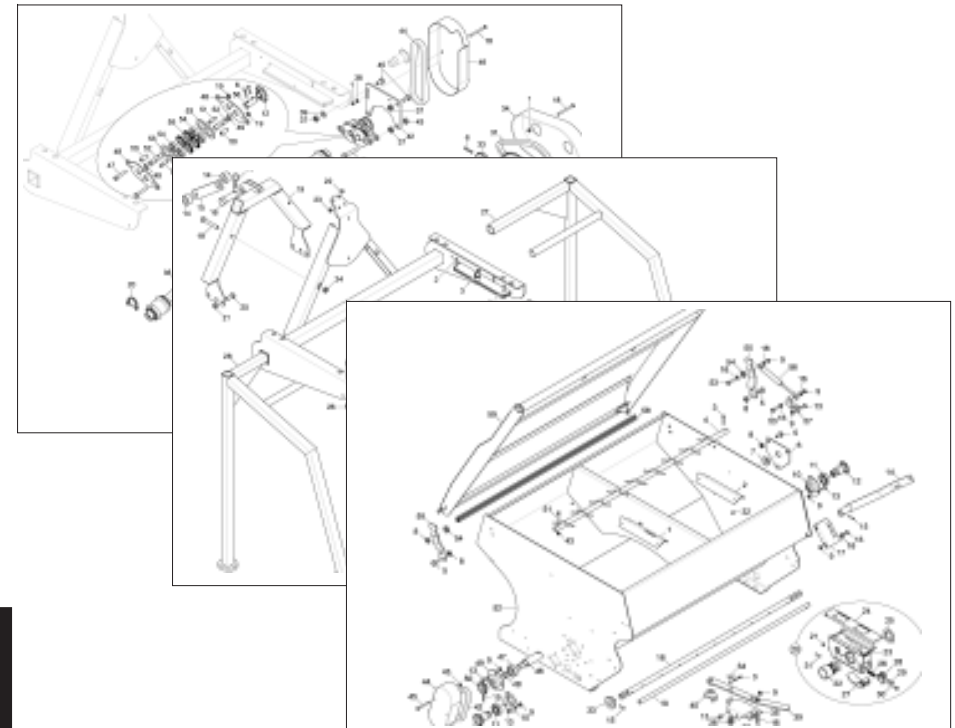

# VITIGREEN

Cod: G19530712 2012-03

- \*) Valido per Paesi UE
- \*) Valid for EU member countries
- \*) Valable dans les Pays UE
- \*) Gilt für EU-Mitgliedsländer
- \*) Válido para Países UE

- IT** PARTI DI RICAMBIO
- EN** SPARE PARTS
- DE** ERSATZTEILE
- FR** PIÈCES DÉTACHÉES
- ES** PIEZAS DE REPUESTO

**PARTI DI RICAMBIO****SPARE PARTS****ERSATZTEILE****PIECES DÉTACHÉES****RESPUESTOS**

Le ordinazioni delle parti di ricambio vanno fatte presso i nostri concessionari di zona e devono essere sempre corredate dalle seguenti indicazioni:

- **Tipo, modello e numero di matricola dell'attrezzatura.** Tali dati sono stampigliati nell'apposita targhetta di cui è dotata ogni attrezzatura.

- **Numero di codice della parte richiesta** rilevabile dal catalogo ricambi.

- **Descrizione del particolare e quantità richiesta.**

- **Numero della tavola.**

- **Mezzo di trasporto.** Nel caso questa voce non sia specificata, la Ditta Costruttrice, pur dedicando a questo servizio una particolare cura, non risponde di eventuali ritardi di spedizione dovuti a cause di forza maggiore.

Le spese di trasporto si intendono sempre a carico del destinatario. La merce viaggia a rischio e pericolo del committente anche se venduta franco destino.

**NOTA:** Il termine **(Dx) Destro** o **(Sx) Sinistro** della macchina o di parti di essa, è inteso guardando la macchina dalla parte posteriore. Le eccezioni saranno indicate.

*Orders must be transmitted through our area dealers and should always include the following indications:*

- **Type, model and serial number of the machine.** *These data are punched on the data plate with which every implement is equipped.*

- **Code number of the required spare part.** *This will be found in the spare parts catalogue.*

- **Description of the part and required quantity.**

- **Table number.**

- **Means of dispatch.** *If this item is not indicated, the Manufacturer, while dedicating particular care to this service, shall not be held responsible for delays in delivery caused by cases of force majeure.*

*Transport expenses shall always be at the consignee's charge. The goods travel at the purchaser's risk and peril even when sold ex destination.*

**NOTE:** *The symbols (Dx) right and (Sx) left, concerning the machine or single parts of it, are referred, as in the figure, to a rear view of them. Exceptions will be indicated.*

Die Bestellungen müssen bei unseren Gebietshändler aufgegeben werden. Bei der Bestellung sind stets die folgenden Angaben zu machen:

- **Typ, Modell und Serien-Nummer des Geräts.** Diese Daten stehen auf dem Typenschild, mit dem jedes Gerät versehen ist.

- **Artikel Nr. der erforderlichen Ersatzteile.** Diese stehen im Ersatzteil-Katalog.

- **Beschreibung des Ersatzteils und die erforderliche Stückzahl.**

- **Tafelnummer.**

- **Versandmittel.** Wenn dieser Punkt nicht spezifiziert wird, haftet die Herstellerfirma nicht für etwaigen Lieferverzug aufgrund höherer Gewalt, auch wenn er diesen Service besonders aufmerksam abwickelt. Die Frachtkosten gehen dagegen immer zu Lasten des Empfängers. Die Ware reist auf Gefahr und Risiko des Auftraggebers, auch wenn frei Haus Verkauft vereinbart worden ist.

**N.B.:** Die Merkzeichen **(Dx) rechts** und **(Sx) links** betreffen eine rückwärtige Aussicht der Maschine oder Teile von ihr (siehe Bild). Ausnahmen werden gezeigt.

*Les ordres doivent être effectués auprès de nos concessionaires de zone en précisant les indications suivantes:*

- **Type, modèle et numéro de série de la machine.** *Ces données sont gravées sur la plaque d'identification de chaque outil.*

- **Numéro de code de la pièce détachée** indiqué sur le catalogue des pièces détachées.

- **Description de la pièce et quantité requise.**

- **Numéro de plan.**

- **Moyen d'expédition.** *Si cette rubrique n'est pas indiquée, le Constructeur, bien que soucieux de ce service, ne répond pas des retards d'expédition pour des causes de force majeure.*

*Les frais de transport sont toujours à la charge du destinataire. La marchandise voyage aux risques et périls de l'acheteur même si vendue franco de port.*

**N.B.:** *Les références (Dx) droit et (Sx) gauche de la machine ou des parties de la même, est entendue, comme de la figure, en regardant la machine de derriere dans le sens de marche.*

Los pedidos han de efectuarse en nuestros concesionarios de zona y deben incluir siempre las siguientes indicaciones:

- **Tipo, modelo y número de matricula del equipo.** Dichos datos están impresos en la relativa placa presente en el equipo.

- **Número de código de la parte requerida** presente en el catálogo respuestas.

- **Descripción de la pieza y cantidad requerida.**

- **Numero de ilustración.**

- **Medio de transporte.** En caso que este ítem no esté especificado, el Fabricante, aún prestando la debidas consideraciones para este aspecto, no responde por eventuales retardos de env'o debidos a causas de fuerza mayor. Los gastos de transporte se consideran siempre a cargo del destinatario. La mercadería viaja bajo riesgo y peligro del comprador, incluso cuando se vende franco destino.

**N.B.:** La refencia **(Dx) derecha** o **(Sx) izquierda** de la máquina o de sus componentes, se entiende, como en la figura, mirando la máquina por la parte trasera. Se indicarán las excepciones.

<i>N° Tavola</i>	<i>Descrizione</i>	<i>Pagina</i>
TAV. 010	TRAMOGGIA .....	4
TAV. 022	TELAIO .....	6
TAV. 031	TRASMISSIONE .....	8
TAV. 040	MONTAGGIO TRASMISSIONE .....	10

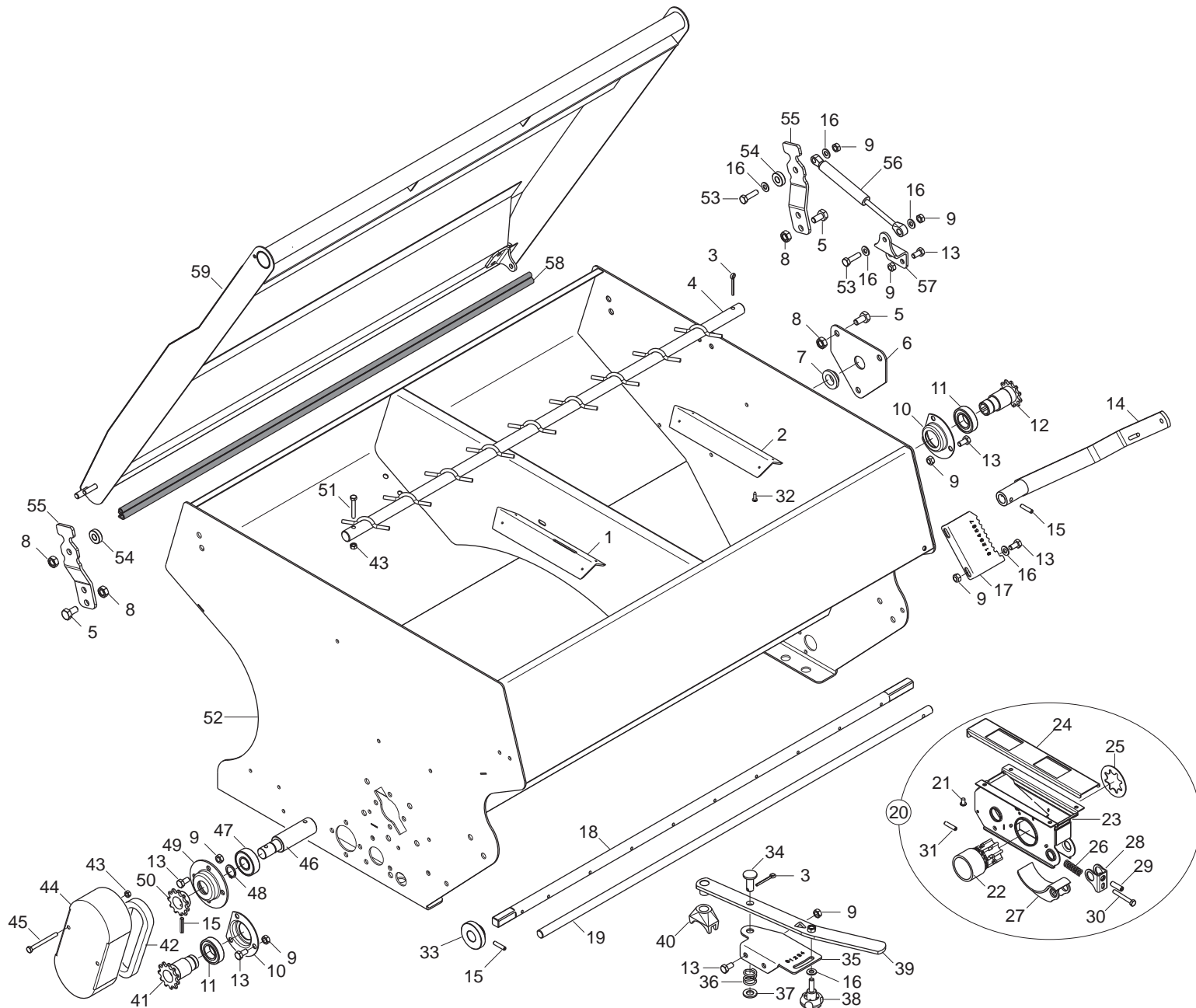

**TRAMOGGIA**

**TAV. 010**

Pos.	Cod.	Descrizione	Description	Description	Benennung	Descripcion
1	G17521430	DIFFUSORE SEME CENTRALE COMPL				
2	G17521420	DIFFUSORE SEME COMPL				
3	F02200162	COPIGLIA 3X 20 U1336 ZN	SPLIT PIN 3 X20 1336 GALVAN.	GOUPILLE 3 X20 1336 ZN	SPLINT 3 X20 1336 ZN	PASADOR 3 X20 1336 ZN
4	G17521290	ALBERO MESCOLO VITIGREEN	MIX SHAFT	ARBRE MELANGEUR	MISCHERWELLE	EJE MEZCLADOR
5	F01020470	VITE M10X1,5X20 U5739 8.8 ZN	BOLT M10X1,5X20 U5739 8.8 ZN	BOLT M10X1,5X20	SCHRAUBE M 10X20	TORNILLO M 10X20
6	G16910910	CHIUSURA PER ALBERO MESCOLO	MIXER SHAFT CLOSURE	FERMETURE ARBRE MELANGEUR	VERSCHLUSS MISCHERWELLE	CIERRE EJE MEZCLADOR
7	G19004420	BOCCOLA SUPP.ASSE AGITATORE	UPPER STIRRER SHAFT BUSH	DOUILLE SUPP. AXE AGITATEUR	OBERE BUCHSE R_HRWELLENACHSE	MANGUITO SOP.EJE AGITADOR
8	F01220033	DADO M10X 1,5 D980 8 ZN	NUT M10X 1,5 D980 8 ZN	ECROU M10X 1,5 D980 8 ZN	MUTTER M10X 1,5 D980 8 ZN	TUERCA M10X 1,5 D980 8 ZN
9	F01220022	DADO M 8X1,25 D980 8 ZN	NUT M8X 1,25 D980 8 ZN	ECROU M8X 1,25 D980 8 ZN	MUTTER M8X 1,25 D980 8 ZN	TUERCA M8X 1,25 D980 8 ZN
10	G22230086	SUPPORTO CUSCINETTO TAGLIATO	CUT BEARING SUPPORT	SUPPORT PALIER COUPE	HALTERUNG LAGER MIT SCHNITT	SOPORTE COJINETE CORTADO
11	F04010135	CUSC.D25 D47 B12 6005 2RS EX->	BEARING D25 D47 B12 6005 2RS			
12	G16930330	PIGNONE DISTRIBUZIONE SEME	GALVAN. PINION DISTR.	PIGNON DISTRIB. ZN	RITZEL VERTEIL. ZN	PINION DISTRIB. ZN
13	F01020432	VITE M 8X1,25X16 U5739 8.8 ZN	BOLT M8X 1.25X16 U5739 8.8 ZN	VIS M8X16	SCHRAUBE M 8X16	TORNILLO M 8X16
14	G16920460	LEVA REGOLAZIONE TASTATORI	FEELER ADJUSTING LEVER	LEVIER DE REGLAGE DES TATEURS	TASTERREGULIERHEBEL	PALANCA DE REGULAC. DE PALPAD
15	F02100110	SPINA E.P. 6X 26 U6873 C70 BR	PIN EL. 6 X26 DIN 1481	FICHE EL.6 X26 DIN 1481	SPANNSTIFT 6 X26 DIN 1481	CLAVIJA EL.6 X26 DIN 1481
16	F01410051	ROS.M8 8,4X 17X1,6 U6592 ZN	WASHER M8 8,4X17X1,6 U6592 ZN	RONDEL. M8 8,4X17X1,6 U6592 ZN	SCHLEIBE M8 8,4X17X1,6 U6592 ZN	ARANDELA M8 8,4X17X1,6 U6592ZN
17	G16920360	SUPPORTO REGOLAZ.TASTATORI ZN	REGULATION SUPPORT	SUPPORT REGLAGE	EINSTELLERHALTERUNG	SOPORTE REGULACIEN
18	G17521310	ASSE DISTRIBUZIONE ZN	GALVAN.DISTRIBUT.SPINDLE	AXE DISTRIBUTEUR ZN	STREUERACHSE ZN	EJE DISTRIBUIDOR ZN
19	G17521300	ASSE TASTATORI ZN VITIGREEN				
20	G16920270	DISTRIBUTORE S COMPL.	COMPL. DISTRIBUTOR S	DISTRIBUTEUR S COMPL.	STREUER S KOMPL.	DISTRIBUIDOR S COMPL.
21	F02250148	RIVETTO STR. 6X12 U9200A AL	PULL RIVET 6X12 ALL	RIVET A RUPTURE 6X12 ALLU	REISSNIETE 6X12 ALL	REMACHE DESGAR. 6X12 AL
22	G19004372	RULLO DISTRIBUTORE SEME	SEED DISTRIBUTION ROLLER			
23	G16930190	SCATOLA DISTRIBUZIONE S	S DISTRIBUTION BOX	BOITE DE DISTRIBUTION S	STREUERKASTEN S	CAJA DE DISTRIBUCION S
24	G16930200	LEVA APERTURA	OPENING LEVER	LEVIER OUVERTURE	HEBEL STREUER	PALANCA MOVIL
25	G16930010	RONDELLA SCORR.RULLO SEME	SLIDING SEED ROLLER WASHER	RONDELLE COULISSANTE ROULEAU G	UNTERLEGSCHLEIBE GLEITUNG SAMEN	ARANDELA DESLIZ. RODILLO SEMIL
26	G18904010	MOLLA SPINTA TASTATORE	FEELER PIN PUSH SPRING	RESSORT POUSSEE PALPEUR	FEDER SCHUB ABTASTER	MUELLE EMPUJE PALPADOR
27	G19004391	TASTATORE	FEELER PIN	T-TEUR	ABTASTER	PALPADOR
28	G16920050	SUPPORTO TASTATORE	FEELER POINT SUPPORT	SUPPORT TATEUR	HALTERUNG ABTASTER	SOPORTE PALPADOR
29	F01050101	VITE M8X1,25X25 U5927 ZN	GRUB-BOLT 8 X25 5927	GOUJON 8 X25 5927	STIFT 8 X25 UNI 5927	TORNILLO SIN CABEZA 8 X25 5927
30	F01020041	VITE M6X1X45 U5737 8.8 ZN	BOLT M6X 1X45 U5737 8.8 ZN	VIS 6 X45 5737 8.G ZN	SCHRAUBE 6 X45 5737 8.G ZN	TORNILLO 6 X45 5737 8.G ZN
31	F02100087	SPINA E.P. 5X 30 U6873 C70 BR	PIN EL. 5 X30 DIN 1481	FICHE EL. 5 X30 DIN 1481	SPANNSTIFT 5 X30 DIN 1481	CLAVIJA EL.5 X30 DIN 1481
32	F01070073	VITE M4,2X1,41X9,5 U6954 4.8NI	BOLT 4-2X 9-5 DIN 7981	VIS 4-2X 9-5 DIN 7981	SCHRAUBE 4-2X 9,5 DIN 7981	TORNILLO 4-2X 9-5 DIN 7981
33	G16920550	BOCCOLA ALBERO DISTRIBUTORE	BUSHING DISTRIBUTION AXLE	BOITE ARBRE DE DISTRIBUTION	BUCHSE ANTRIEBSWELLE	MANGUITO EJE DISTRIBUIDOR
34	G16920520	PERNO MOLLA DI COMPRESIONE	COMPRESSION SPRING PIN	PIVOT RESSORT DE COMPRESSION	BOLZEN DRUCKFEDER	PERNO MUELLE DE COMPRESIEN
35	G17521230	SUPPORTO LEVA REGOLAZIONE ZN				
36	G18904000	MOLLA COMPRESIONE DISTRIB.	DISTRIB. COMPRESSION SPRING	RESSORT COMPRESSION DISTRIB.	DRUCKFEDER STREUER	MUELLE COMPRESIEN DISTRIB.
37	F01410076	ROS.M12 13X 24X2,5 U6592 ZN	WASHER D12 U6592 ZN	RONDELLE D12 U6592 ZN	SCHLEIBE D12 U6592 ZN	ARANDELA D12 U6592 ZN
38	F06220019	VOLANTINO 4L.VTPX/40 M8X25 IX	4-LOBE HANDWHEEL M8X25	VOLANT 4 LOBES M8X25	HANDRAD 4 BUCKEL M8X25	VOLANTE 4 LOBI M8X25
39	G17521250	LEVA APERTURA DOSATORI				
40	G16920540	BLOCCO GUIDA ALBERO DISTRIB.	DISTRIB. SHAFT GUIDE BLOCK	BLOCAGE GUIDE ARBRE DISTRIBUTI	F_HRUNGSBLOCK VERTEILERWELLE	BLOQUE GUIA ARBOL DISTRIB.
41	G17530810	PIGNONE Z11 Q.16,4 ZN	PINION Z11 Q.16,4 ZN			
42	F06080012	CATENA 1/2 ISO 083 30 MAGLIE	CHAIN 1/2 ISO 083 30 SHACKLE			
43	F01200232	DADO M 6X 1 U5588 6.8 ZN	NUT 6 UNI 5588 6.8 GALVANIZED	ECROU 6 UNI 5588 6.8 ZN	MUTTER 6 UNI 5588 6.8 ZN	TUERCA 6 UNI 5588 6.8 ZN
44	G17530710	CARTER TRASMISSIONE AGITATORE	MIXER TRASM. CARTER			
45	F01020047	VITE M6X1X70 U5737 8.8 ZN	BOLT M6X 1X70 U5737 8.8 ZN	VIS 6 X70 5737 8.G ZN	SCHRAUBE 6 X70 5737 8.G ZN	TORNILLO 6 X70 5737 8.G ZN
46	G16930310	PERNO ROTAZ.ALBERO AGITAT.ZN	ROTATION PIVOT	PIVOT ROTATION	ZAPFEN DREHUNG	PERNO ROTACIEN
47	F04010156	CUSC.d20 D47 B14 6204 2RSH	BEARING d20 D47 B14 6204 2RSH			
48	F02050078	ANELLO E. DE 20X 1,2 U7435 C70	SEEGER RING E. 20X1,2 7435 C70	SEEGER 20X 1,2 U7435 C70	SEEGER E. 20X 1,2 U7435 C70	
49	G16242190	SUPPORTO CUSCINETTO	BEARING SUPPORT	SUPPORT PALIER	LAGERBSCHSE	SOPORTE COJINETE
50	G16230040	PIGNONE Z-11 ZN	GEAR Z.11 GALVANIZED	PIGNON Z 11 ZN	RITZEL Z 11 ZN	PI $\frac{1}{2}$ N Z 11 ZN P
51	F01020040	VITE M6X1X40 U5737 8.8 ZN	BOLT M6X 1X40 U5737 8.8 ZN	VIS 6 X40 5737 8.G ZN	SCHRAUBE 6 X40 5737 8.G ZN	TORNILLO 6 X40 5737 8.G ZN
52	G17521220	TRAMOGGIA VITIGREEN 9 U	HOPPER VITIGREEN 9 U			
53	F01020445	VITE M8X1,25X30 U5739 8.8 ZN	BOLT M8X30	VIS M 8X30	SCHRAUBE M 8X30	TORNILLO M 8X30
54	G18801680	BOCCOLA 11 X25 X7,5 ZN	BUSHING 11X25X7,5 GALVA	BOITE 11X25X7,5 ZN	BsCHSE 11X25X7,5 ZN	CASQUILLO 11X25X7,5 ZN
55	G16913600	STAFFA ROTAZIONE COPERCHIO ZN	ROTATION BRACKET	BRIDE DE ROTATION	ROTATIONB_GEL	ABRAZADERA DE ROTACIEN
56	F02400011	MOLLA A GAS 400 N	GAS SPRING 400 N	RESSORT A GAZ 400 N	GASFEDER 400 N	MUELLE DE GAS 400 N
57	G16313680	ATTACCO STELO MOLLA ZN				
58	F03011141	GUARNIZIONE GOMMA				
59	G17510510	COPERCHIO VITIGREEN 9 U				

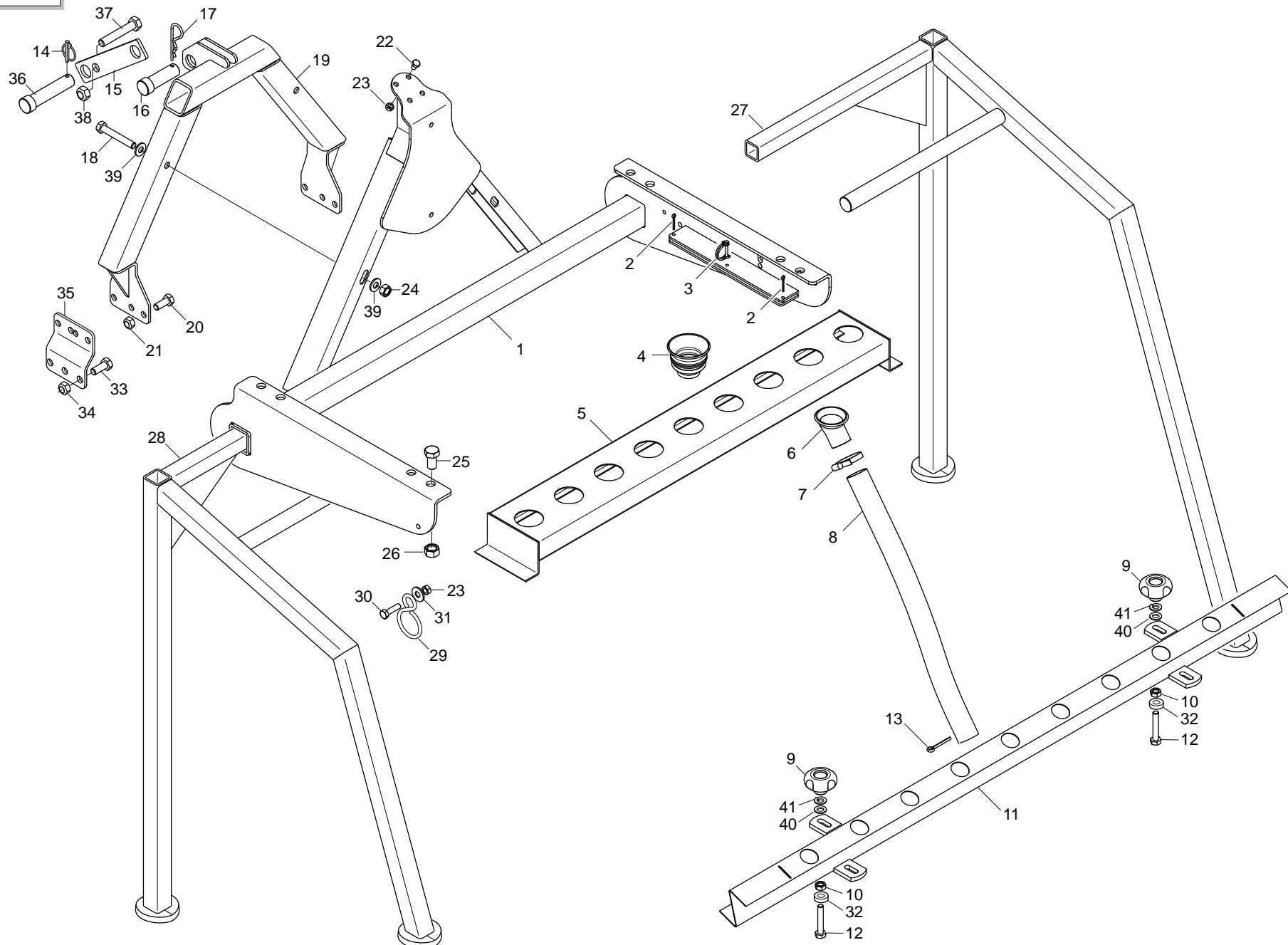

**TELAIO**

**TAV. 022**

Pos.	Cod.	Descrizione	Description	Description	Benennung	Descripcion
1	M75400408	TELAIO VITIGREEN				
2	F02200162	COPIGLIA 3X 20 U1336 ZN	SPLIT PIN 3 X20 1336 GALVAN.	GOUPILLE 3 X20 1336 ZN	SPLINT 3 X20 1336 ZN	PASADOR 3 X20 1336 ZN
3	F02200595	SPINOTTO X INGRANAGGIO	PIN X GEAR			
4	G19003070	CUFFIA SUPERIORE	TELESCOPIC TUBE SUPPORT	PROTECTEUR SUPERIEUR	OB. KASTEN	ENVOLTURA SUPERIOR
5	G17521270	BUSSOLIERA VITIGREEN	BUSSOLIERA VITIGREEN			
6	G19004360	IMBUTO DISCESA SEME-CONCIME	SEED-FERTILIZER FUNNEL	ENTONNOIR CHUTE GRAINE-ENGRAIS	TRICHTER D. NGER-SAMENFALL	EMBUDO CAIDA SEMILLAS-ABONO
7	F02300020	FASCETTA STRING. 32/50 H.9	STRING FASTEN.STRAPS 32/50 H.9	COLLIER 32/50 H.9	SHELLE 32/50 H.9	ABRAZADERA 32/50 H.8
8	F03100530	TUBO EOLO PU-P D.32	EOLO TUBE PU-P D.33			
9	F06220022	VOLANTINO 4LOBI D.60-M10 FEM.	4-LOBE HANDWHEEL M10	VOLANT 4 LOBES M10	HANDRAD 4 BUCKEL M10	VOLANTE 4 LOBI M10
10	F01200270	DADO M10X 1,5 U5588 6.8 ZN	NUT M10X 1,5 U5588 6.8 ZN	ECROU M10X 1,5 U5588 6.8 ZN	MUTTER M10X 1,5 U5588 6.8 ZN	TUERCA M10X 1,5 U5588 6.8 ZN
11	M75400400	BUSSOLIERA 9 U 1300-1500				
12	F01020479	VITE M10X1,5X35 U5739 8.8 ZN	BOLT M10X1,5X35 U5739 8.8 ZN	VIS M10X1,5X35 U5739 8.8 ZN	SCHR. M10X1,5X35 U5739 8.8 ZN	TORN. M10X1,5X35 U5739 8.8 ZN
13	F02200197	COPIGLIA 4X 50 U1336 ZN	SPLIT PIN 4 X50 1336 GALVAN.	GOUPILLE 4 X50 1336 ZN	SPLINT 4 X50 1336 ZN	PASADOR 4 X50 1336 ZN
14	F02200529	SPINA SCATTO D.11 ZN	SNAP PIN D.11	FICHE A DETENTE D.11	EINRASTSTIFT D.11	CLAVIJA DE MUELLE D.11
15	M75400403	PIATTO				
16	G16910310	SPINA 25X62 ZN	PIN ZN	GOUPILLE ZN	BOLZENSTIFT ZN	PASADOR ZN
17	F02200374	COPIGLIA R 4X 82 ZN	SPRING SPLIT PIN 4X82	GOUPILLE 4X82	SPLINT 4X82	PASADOR 4X82
18	F01020166	VITE M12X1,75X80 U5737 8.8 ZN	BOLT M12X1,75X80 U5737 8.8 ZN	VIS M12X1,75X80 U5737 8.8 ZN	SCHRA.M12X1,75X80 U5737 8.8 ZN	TORN. M12X1,75X80 U5737 8.8 ZN
19	M75400406	TRIANGOLO ATTACCO ERPICE				
20	F01020510	VITE M12X1,75X30 U5739 8.8 ZN	BOLT M 12X30	VIS M 12X30	SCHRAUBE M 12X30	TORNILLO M 12X30
21	F01220048	DADO M12X1,75 D980 8 ZN	NUT M12X1,75 D980 8 ZN	ECROU M12X1,75 D980 8 ZN	SCHIBE M12X1,75 D980 8 ZN	TUERCA M12X1,75 D980 8 ZN
22	F01020436	VITE M 8X1,25X 20 U5739 8.8 ZN	BOLT M8X1,25X20 U5739 8.8 ZN	VIS M8X1,25X20 U5739 8.8 ZN	SCHRA. M8X1,25X20 U5739 8.8 ZN	TORN. M8X1,25X20 U5739 8.8 ZN
23	F01220022	DADO M 8X1,25 D980 8 ZN	NUT M8X 1,25 D980 8 ZN	ECROU M8X 1,25 D980 8 ZN	MUTTER M8X 1,25 D980 8 ZN	TUERCA M8X 1,25 D980 8 ZN
24	F01200293	DADO M12X1,75 U5588 6.8 ZN	NUT M12X1,75 U5588 6.8 ZN	ECROU M12X1,75 U5588 6.8 ZN	MUTTER M12X1,75 U5588 6.8 ZN	TUERCA M12X1,75 U5588 6.8 ZN
25	F01020562	VITE M16X2X30 U5739 8.8 ZN	BOLT M16X2X30 U5739 8.8 ZN	VIS M16X2X30 U5739 8.8 ZN	SCHRAUBE M16X2X30 U5739 8.8 ZN	TORNILLO M16X2X30 U5739 8.8 ZN
26	F01200324	DADO M16X 2 U5588 8.8 ZN	NUT M16X2 U5588 8.8 ZN	ECROU M16X2 U5588 8.8 ZN	MUTTER M16X2 U5588 8.8 ZN	TUERCA M16X2 U5588 8.8 ZN
27	G17510470	SUPPORTO TRAMOGGIA DX	HOPPER SUPPORT RIGHT			
28	G17510540	SUPPORTO TRAMOGGIA SX	HOPPER SUPPORT LEFT			
29	G65336004	MOLLA SPEC.ZN AGG.SEMINAT. SP	SPEC SPRING- ZN ADD. SEEDER SP	RESSORT SPEC. ZN ATTELAGE SEME	SPEZIALFEDER ZN SZELEM. KUPPL.	MUELLE ESPEC. ZN CONEX. SEMBRA
30	F01020445	VITE M8X1,25X30 U5739 8.8 ZN	BOLT M8X30	VIS M8X30	SCHRAUBE M8X30	TORNILLO M8X30
31	F01420049	ROS.M8 8,4X 32X 2 U6593 ZN	WASHER M8 8,4X32X2 U6593 ZN	RONDELLA M8 8,4X32X2 U6593 ZN	SCHEIBE M8 8,4X32X2 U6593 ZN	ARANDELA M8 8,4X32X2 U6593 ZN
32	M33100599	DISTANZ. D=25 D=10,5 L=10 ZG				
33	F01010317	VIT.M14X 1,5X 35 U5740 8.8 ZN				
34	F01220059	DADO M14X 1,5 D980 8 ZN	NUT M14X 1,5 D980 8 ZB	ECROU M14X 1,5 D980 8 ZB	MUTTER M14X 1,5 D980 8 ZB	TUERCA M14X 1,5 D980 8 ZB
35	M75400401	STAFFA				
36	F20100063	PERNO D25 L91 C40 ZN	PIN D25 L91 C43 ZN	BOULON D25 L91 C43 ZN	BOLZEN D25 L91 C43 ZN	PERNO D25 L91 C43 ZN
37	F01020580	VITE M16X2X100 U5739 8.8 ZN	BOLT M16X 2X100 8.8 U5739 ZN	VIS M16X 2X100 8.8 U5739	SCHARUBE M16X 2X100 8.8 U5739	TORNILLO M16X 2X100 8.8 U5739
38	F01220266	DADO M16X 2 D980 8 ZN	NUT M16X 2 D980 8 ZN	ECROU M16X 2 D980 8 ZN	MUTTER M16X 2 D980 8 ZN	TUERCA M16X 2 D980 8 ZN
39	F01410076	ROS.M12 13X 24X2,5 U6592 ZN	WASHER D12 U6592 ZN	RONDELLE D12 U6592 ZN	SCHEIBE D12 U6592 ZN	ARANDELA D12 U6592 ZN
40	F01410064	ROS.M10 10,5X 20X 2 U6592 ZN	WASHER M10 10,5X20X2 U6592 ZN	RONDELL.M10 10,5X20X2 U6592 ZN	SCHEIBE M10 10,5X20X2 U6592 ZN	ARAND. M10 10,5X20X2 U6592 ZN
41	F01480112	ROS.G 10,5X18,9X 3 EX.C70 ZN	GROWER WASHER D.10	RONDELLE GROWER D.10	SCHEIBE GROWER D.10	ARANDELA GROWER D.10

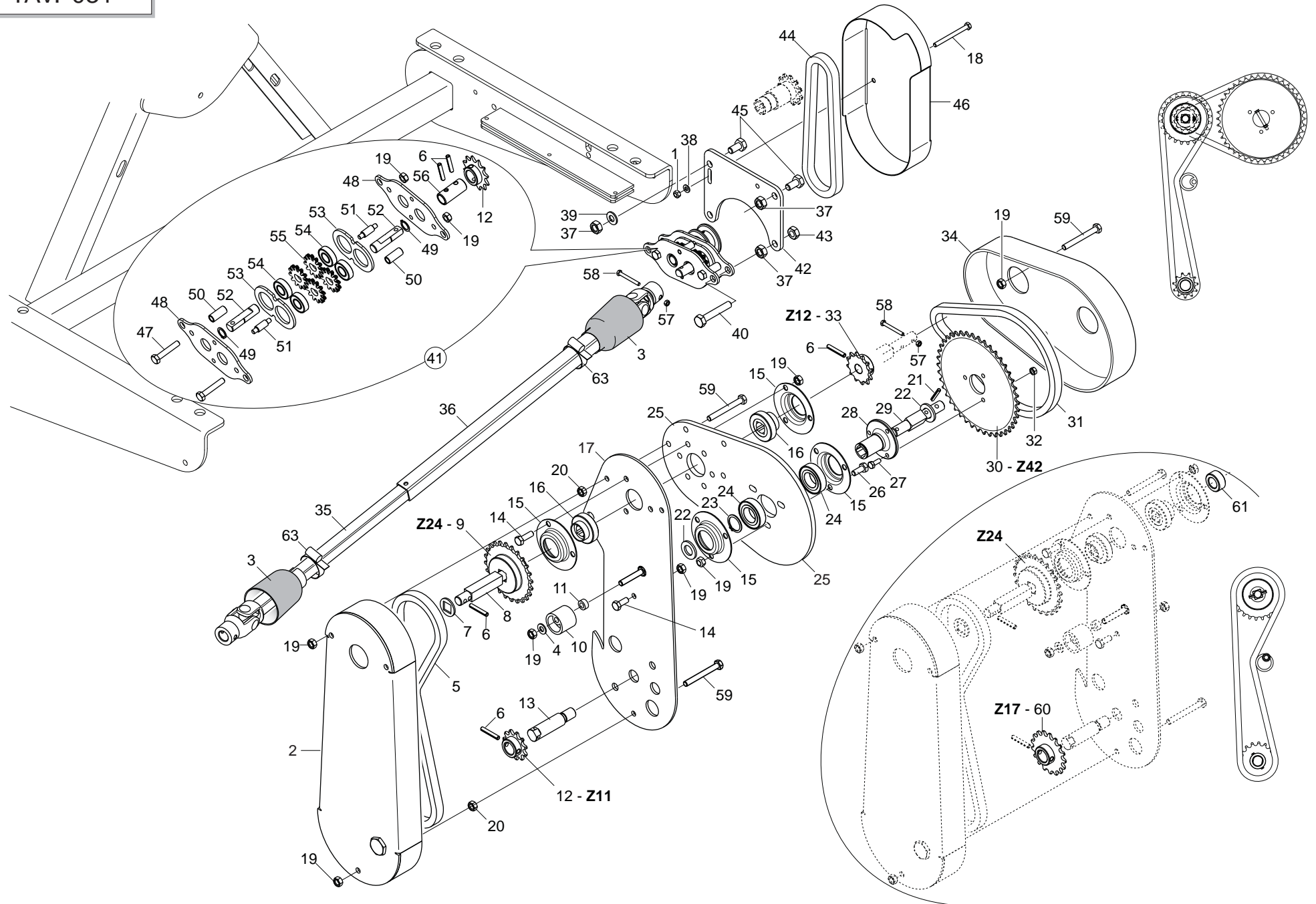



# TRASMISSIONE

TAV. 030

Pos.	Cod.	Descrizione	Description	Description	Benennung	Description
1	F01200232	DADO M 6X 1 U5588 6.8 ZN	NUT 6 UNI 5588 6.8 GALVANIZED	ECROU 6 UNI 5588 6.8 ZN	MUTTER 6 UNI 5588 6.8 ZN	TUERCA 6 UNI 5588 6.8 ZN
2	M75400310	CARTER TRASM.RULLO ERPICE				
3	G66248094	COPRICARDANO SP	UNIVERSAL JOINT COVER SP	COUVRE-CARDAN SP	KARDANABDECKUNG SP	CUBRECARDæN SP
4	F01410051	ROS.M8 8,4X 17X1,6 U6592 ZN	WASHER M8 8,4X17X1,6 U6592 ZN	RONDEL. M8 8,4X17X1,6 U6592 ZN	SCHEIBE M8 8,4X17X1,6 U6592 ZN	ARANDELA M8 8,4X17X1,6 U6592ZN
5	F06080037	CATENA 1/2 ISO 083 73 MAGLIE	CUT-DOWN CHAIN .1/2 ISO 083 73	TR. CH.1/2 ISO 083 73 MAILLES	KETTENZNGE 1/2 ISO 083 73 GL	TRECHO CADENA 1/2 ISO 083 73 E
6	F02100118	SPINA E.P. 6X 36 U6873 C70 BR	ELASTIC PIN 6X36	GOUJON ELASTIQUE 6X36	SPANNHUELSE 6X36	ESPINA ELASTICA 6X36
7	G18701650	RONDELLA FORO QUADRO ZN	WASHER 16,5X30X2,5 ZN	RONDELLE 16,5X30X2,5 ZN	UNTERLEGSCHEIBE 16,5X30X2,5 ZN	ARANDELA 16,5X30X2,5 ZN
8	G17530860	PERNO TRASMISSIONE RULLO ZN				
9	G20900041	PIGNONE Z24 1/2X3/16 Q.16,4 ZN	GEAR 1/2 Z-24 F.Q. HL	ENGRENAGE 1/2 Z-24 TROUS CARRE	ZAHNRAD 1/2 Z-24 F.Q. HL	ENGRANAJE 1/2 Z-24 F.Q. HL
10	G66248207	TENDICATENA SPAND. SP-520	CHAIN TENSIONER	TENDEUR DE CHAINE EPAND. ENGR.	KETTENSANNER DsNGERSTR. SP-52	SENSOR DE CADENA ABON. SP-520
11	G20980050	BOCCOLA 15X7X8,5 ZN	BUSHING 15X7X8-5 ZN	BOITE 15X7X8-5 ZN	BsCHSE 15X7X8-5 ZN	CASQUILLO 15X7X8-5 ZN
12	G16230040	PIGNONE Z-11 ZN	GEAR Z.11 GALVANIZED	PIGNON Z 11 ZN	RITZEL Z 11 ZN	PI¼N Z 11 ZN P
13	G17530460	ASSE CORONA ENCODER	ENCODER SHAFT+B474 LOAD RING	AXE COURONNE ENCODEUR	ACHSE CORONA ENCODER	EJE CORONA ENCODER
14	F01020440	VITE M 8X1,25X25 U5739 8.8 ZN	BOLT M8X1,25X25 U5739 8.8 ZN	VIS M8X1,25X25 U5739 8.8 ZN	SCHRA. M8X1,25X25 U5739 8.8 ZN	TORNILLO M8X1,25X25 U5739 8.8 ZN
15	G22230094	SUPPORTO CUSCINETTO	BEARING SUPPORT	SUPPORT PALIER	LAGERBsCHSE	SOPORTE COJINETE
16	G14830390	CUSCINETTO FORO QUADRO	SQUARE-HOLED BEARING	ROULEMENT AL+SAGE CARR+	VIERKANTLAGER	COJINETE ORIFICIO CUADRADO
17	M75400307	PIASTRA SUP.TRASM.RULLO				
18	F01020047	VITE M6X1X70 U5737 8.8 ZN	BOLT M6X 1X70 U5737 8.8 ZN	VIS 6 X70 5737 8.G ZN	SCHRAUBE 6 X70 5737 8.G ZN	TORNILLO 6 X70 5737 8.G ZN
19	F01220022	DADO M 8X1,25 D980 8 ZN	NUT M8X 1,25 D980 8 ZN	ECROU M8X 1,25 D980 8 ZN	MUTTER M8X 1,25 D980 8 ZN	TUERCA M8X 1,25 D980 8 ZN
20	F01200244	DADO M 8X1,25 U5588 6.8 ZN	NUT M8 X1,25 U5588 6.8 ZN	ECROU M8 X1,25 U5588 6.8 ZN	MUTTER M8 X1,25 U5588 6.8 ZN	TUERCA M8 X1,25 U5588 6.8 ZN
21	F02100091	SPINA E.P. 5X 45 U6873 C70 BR	PIN EL. .5 X45 DIN 1481	FICHE EL. 5 X45 DIN 1481	SPANNSTIFT 5 X45 DIN 1481	CLAVIJA EL.5 X45 DIN 1481
22	F01410100	ROS.M16 17X 30X 3 U6592 ZN	WASHER M16 17X30X3 U6592 ZN	RONDELLE M16 17X30X3 U6592 ZN	SCHEIBE M16 17X30X3 U6592 ZN	ARANDELA M16 17X30X3 U6592 ZN
23	F02050101	ANELLO E. DE 25X 1,2 U7435 C70	SEEGER RING E. 25X1,2 7435 C70	SEEGER E. 25X 1,2 U7435 C70	SEEGERING E. 25X 1,2 U7435 C70	ANILLO E. 25X 1,2 U7435 C70
24	F04010135	CUSC.D25 D47 B12 6005 2RS EX->	BEARING D25 D47 B12 6005 2RS			
25	M75400314	PIASTRA SUPP. TRASMISSIONE				
26	F01020436	VITE M 8X1,25X 20 U5739 8.8 ZN	BOLT M8X1,25X20 U5739 8.8 ZN	VIS M8X1,25X20 U5739 8.8 ZN	SCHRA. M8X1,25X20 U5739 8.8 ZN	TORN. M8X1,25X20 U5739 8.8 ZN
27	F01020403	VITE M6X1X16 U5739 8.8 ZN	BOLT M6X1X16 U5739 8.8 ZN	VIS M6X1X16 U5739 8.8 ZN	SCHRAUBE M6X1X16 U5739 8.8 ZN	TORNILLO M6X1X16 U5739 8.8 ZN
28	G17530870	FLANGIA CORONA ZN				
29	M75400318	PERNO D=15 L=103 ZN				
30	G20890128	CORONA Z-42 SP	RING GEAR Z-42 SP	COURONNE Z-42 SP	KRANZ Z-42 SP	CORONA Z-42 SP
31	F06080128	CATENA 1/2 ISO 084 53 MAGLIE	CHAIN 1/2 ISO 084 53 SHACKLE			
32	F01220211	DADO TRISTOP M 6	NUT- TRISTOP M 6	ECROU TRISTOP M 6	MUTTER TRISTOP M 6	TUERCA TRISTOP M 6
33	G20860088	INGRANAGGIO 1/2 Z-12 F.T.	GEAR 1/2 Z-12 F.T.	ENGRENAGE 1/2 Z-12 TROUS RONDS	ZAHNRAD 1/2 Z-12 F.T.	ENGRANAJE 1/2 Z-12 F.T.
34	M75400315	CARTER RIDUZIONE				
35	G16035170	GIUNTO Q.20 L=700				
36	G16035150	GIUNTO Q.25 L=700				
37	F01200270	DADO M10X 1,5 U5588 6.8 ZN	NUT M10X 1,5 U5588 6.8 ZN	ECROU M10X 1,5 U5588 6.8 ZN	MUTTER M10X 1,5 U5588 6.8 ZN	TUERCA M10X 1,5 U5588 6.8 ZN
38	F01410037	ROS.M6 6,4X12,5X1,6 U6592 ZN	PLANE WASHER D.6	RONDELLE D.6	SCHEIBE D.6	ARANDELA D.6
39	F01410062	ROS.M10 10,5X 18X 2 U6592 ZN	WASHER M10 10,5X 18X 2 U6592			
40	F01020118	VITE M10X1,5X60 U5737 8.8 ZN	BOLT 10X60 5737 8.G GALVANIZED	VIS 10X60 5737 8.G ZN	SCHRAUBE 10X60 5737 8.G ZN	TORNILLO 10X60 5737 8.G ZN
41	G17530740	INVERSIONE TRASMISSIONE COMPL				
42	G17510390	PIASTRA ATTACCO INVERSIONE				
43	F01220033	DADO M10X 1,5 D980 8 ZN	NUT M10X 1,5 D980 8 ZN	ECROU M10X 1,5 D980 8 ZN	MUTTER M10X 1,5 D980 8 ZN	TUERCA M10X 1,5 D980 8 ZN
44	F06080009	CATENA 1/2 ISO 083 41 MAGLIE	CHAIN 1/2 ISO 083 41			
45	F01020470	VITE M10X1,5X20 U5739 8.8 ZN	BOLT M10X1,5X20 U5739 8.8 ZN	VIS M 10X20	SCHRAUBE M 10X20	TORNILLO M 10X20
46	G17530750	CARTER INVERSIONE TRASSMISS.				
47	F01020072	VITE M 8X1,25X50 U5737 8.8 ZN	BOLT M8X1,25X50 U5737 8.8 ZN	VIS M8X1,25X50 U5737 8.8 ZN	SCHR. M8X1,25X50 U5737 8.8 ZN	TORN. M8X1,25X50 U5737 8.8 ZN
48	G17530720	FIANCO INVERSIONE TRASSMISS.ZN				
49	F02050034	ANELLO E. DE 15X 1 U7435 C70	ELASTIC RING DE 15X 1	BAGUE ELASTIQUE DE 15X 1	RING DE 15X 1	ANILLO DE 15X 1
50	G18802720	BOCCOLA 8,5X12X28 ZN	BUSHING 8,5X12X28 ZN			
51	G16330510	DISTANZIALE GRUPPO INVERS. ZN				
52	M75400317	PERNO D=15 L=57 ZN				
53	G16330500	FIANCO INTERNO RINVIO ZN				
54	F04010125	CUSC.D15 D32 B9 6002 2RS1	BEARING D15 D32 B9 6002 2RS1	PALIER 6002 2RS1	LAGER 6002 2RS1	COJINETE 6002 2RS1
55	G16033820	INGRANAGGIO M3 Z12 ZN				
56	G17530730	DISTANZIALE TRASMISSIONE ZN				
57	F01220200	DADO M 5X 0,8 D980 8 ZN	NUT M5X 0,8 D980 8 ZN	ECROU M5X 0,8 D980 8 ZN	MUTTER M5X 0,8 D980 8 ZN	TUERCA M5X 0,8 D980 8 ZN
58	F01020024	VITE M5X0,8X40 U5737 8.8 ZN	BOLT M5X0,8X40 U5737 8.8 ZN	VIS 5X40 5737 8.G ZN	SCHRAUBE 5X40 5737 8.G ZN	TORNILLO 5X40 5737 8.G ZN
59	F01020454	VITE M 8X1,25X70 U5739 8.8 ZN	BOLT M8X1,25X70 U5739 8.8 ZN	VIS M8X1,25X70 U5739 8.8 ZN	SCHRA. M8X1,25X70 U5739 8.8 ZN	TORN. M8X1,25X70 U5739 8.8 ZN
60	G16330010	INGRANAGGIO Z-17	GEAR Z-17	ENGRENAGE Z-17	ZAHNRAD Z-17	ENGRANAJE Z-17
61	G18801860	BOCCOLA 17,25X30 X14	BUSHING 17,25X30X14 GALV.	BOITE 17,25X30X14 ZN	BsCHSE 17,25X30X14 ZN	CASQUILLO 17,25X30X14 ZN
62	G16035150	GIUNTO Q.25 L=700				
63	F02300017	FASCETTA STRING. 20/32 H.9	STRING FASTEN.STRAPAS 20/32 H.9	COLLIER DE SERRAGE 20/32 H.9	SHELLE 20/32 H.9	ABRAZADERA 20/32 H.9

**DLV cod. M992...**

Montaggio supporto rullo Sx per DLV con VITIGREEN

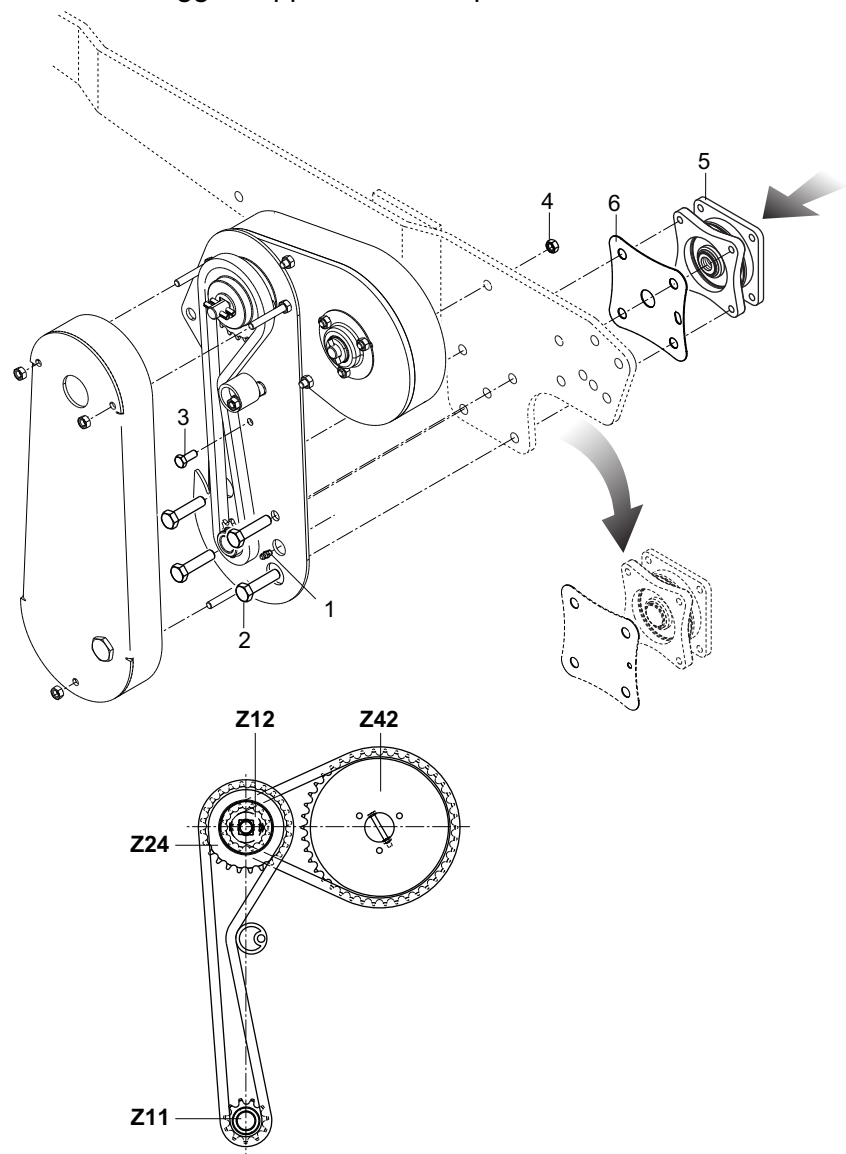

**DELFINO cod. M98C...**

Montaggio supporto rullo Sx per DELFINO con VITIGREEN

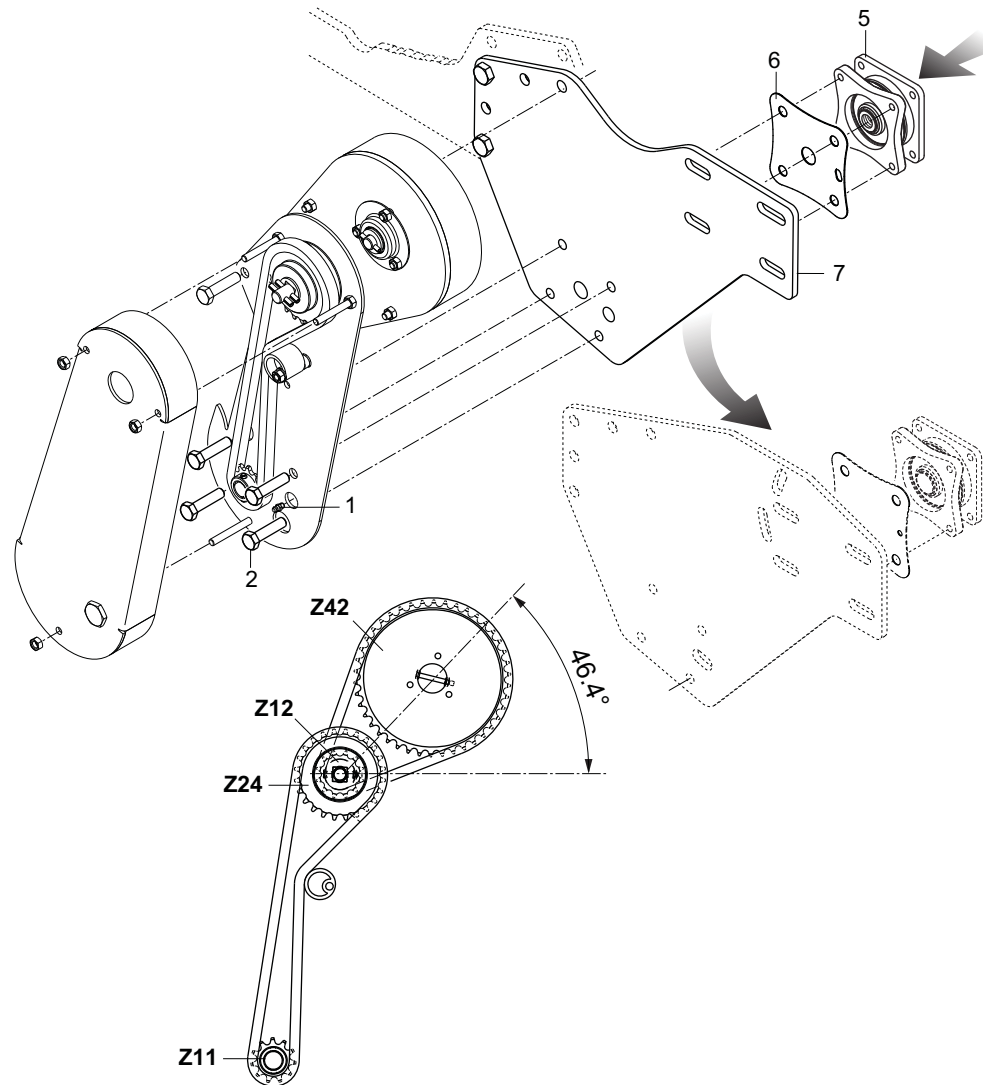

# MONTAGGIO TRASMISSIONE

TAV. 040

Pos.	Cod.	Descrizione	Description	Description	Benennung	Descripcion
1	F01100011	ING.M 6X1 7663-A 9SMNPB28 ZN	GREASE NIPPLE M6X1 7663-A ZN	GRAISS. A BILLE M6X1 7663A ZN	SCHMIERBUECHE M6X1 7663-A ZN	ENGRAS. DE ESFERAS M6X1 7663-A
2	F01010288	VITE M12X1,25X35 U5740 8.8 ZN	BOLT M12X1,25X35 U5740 8.8 ZN	VIS M12X1,25X35 U5740 8.8 ZN	SCHR.M12X1,25X35 U5740 8.8 ZN	TORN.M12X1,25X35 U5740 8.8 ZN
3	F01020436	VITE M 8X1,25X 20 U5739 8.8 ZN	BOLT M8X1,25X20 U5739 8.8 ZN	VIS M8X1,25X20 U5739 8.8 ZN	SCHRA. M8X1,25X20 U5739 8.8 ZN	TORN. M8X1,25X20 U5739 8.8 ZN
4	F01220022	DADO M 8X1,25 D980 8 ZN	NUT M8X 1,25 D980 8 ZN	ECROU M8X 1,25 D980 8 ZN	MUTTER M8X 1,25 D980 8 ZN	TUERCA M8X 1,25 D980 8 ZN
5	G17530470	SUPPORTO RULLO OSCILLANTE SX	LEFT OSCILLANT ROLLER SUPPORT	SUPPORT ROULEAU OSCILLANT GCH	HALTERUNG SCHWINGENDE WALZE LI	SOPORTE RODILLO OSCILANTE IZQ.
6	M43400610	GUARN. METALLICA SP.1 SEMINAT.				
7	M43400622	FIANCATA RULLO X SEMINATRICE				

**USATE SEMPRE RICAMBI ORIGINALI  
ALWAYS USE ORIGINAL SPARE PARTS  
IMMER DIE ORIGINAL-ERSATZTEILE VERWENDEN  
EMPLOYEZ TOUJOURS LES PIECES DE RECHANGE ORIGINALES  
UTILIZAR SIEMPRE REPUESTOS ORIGINALES**

# **GASPARDO**

**Servizio Assistenza Tecnica - After Sales Service  
Servizio Ricambi - Spare Parts Service  
+39 0434 695410**

DEALER:

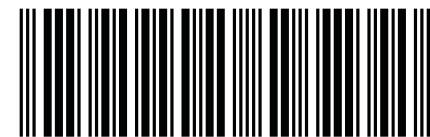

\*G19530712\*



**MASCHIO GASPARDO SpA**  
**Registered Office and Production Plant**  
Via Marcello, 73 - 35011 Campodarsego (Padova) - Italy  
Tel. +39 049 9289810  
Fax +39 049 9289900  
info@maschio.com  
www.maschionet.com

**MASCHIO DEUTSCHLAND GMBH**  
Äußere Nürnberger Straße 5  
D - 91177 Thalmässing - Deutschland  
Tel. +49 (0) 9173 79000  
Fax +49 (0) 9173 790079  
dialog@maschio.de  
www.maschionet.de

**MASCHIO FRANCE Sarl**  
1, Rue de Mérignan ZA  
F - 45240 La Ferte St. Aubin  
France  
Tel. +33 (0) 2.38.64.12.12  
Fax +33 (0) 2.38.64.66.79  
info@maschio.fr

**000 МАСКИО-ГАСПАРДО РУССИЯ**  
Улица Пушкина, 117 Б  
404126 Волжский  
Волгоградская область  
Тел. +7 8443 515152  
факс. +7 8443 515153  
info@maschio.ru

**MASCHIO GASPARDO SpA**  
**Production Plant**  
Via Mussons, 7 - 33075 Morsano al Tagliamento (PN) - Italy  
Tel. +39 0434 695410  
Fax +39 0434 695425  
info@gaspardo.it

**MASCHIO-GASPARDO USA Inc**  
120 North Scott Park Road  
Eldridge, IA 52748 - USA  
Ph. +1 563 2859937  
Fax +1 563 2859938  
info@maschio.us

**MASCHIO-GASPARDO ROMANIA S.R.L.**  
Strada Înfrâritirii, F.N.  
315100 Chisineu-Cris (Arad) -România  
Tel. +40 257 307030  
Fax +40 257 307040  
info@maschio.ro

**MASCHIO IBERICA S.L.**  
**MASCHIO-GASPARDO POLAND**  
**MASCHIO-GASPARDO UCRAINA**  
**GASPARDO-MASCHIO TURCHIA**  
**MASCHIO-GASPARDO CINA**  
**MASCHIO-GASPARDO INDIA**  
**MASCHIO-GASPARDO KOREA**