

Instruction for work
Betriebsanleitung
List of spare parts
Ersatzteilliste



SIP

SPIDER 350

kreiselheuer

rotary tedder

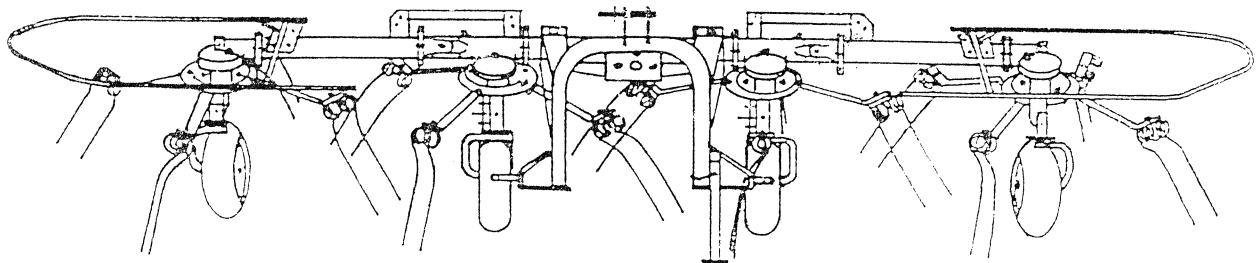

Valid from serial number on:
Gültig ab Maschinnummer:
SPIDER 350 = 3291



SIP

STROJNA INDUSTRIJA d.d.
3311 Šempeter v Savinjski dolini
Slovenija

1987
Tel: +386 (03) 7038 500
Fax: +386 (03) 7038 663
~~+386 (03) 7038 674~~

No.on the figure Numer anzeichn.	Catalogue no. Katalog nummer	Description	Benennung	Quantity Stück
1	151940109-337.01.001.0	Gear 1	Zahnrad 1	1
2	151940207-337.01.002.0	Gear 2	Zahnrad 2	1
3	151940001-337.01.003.0	Shaft	Welle	1
4	152226601-340.00.003.0	P.T.O. Shaftz protection	Gelenkwellenschutz	1
5	151037103-325.01.001.2	Gear-box housing	Getriebegehäuse 1	1
6	151012601-510.03.041.0	Locking screw	Verschlusszapfen	1
7	151012905-455.05.013.0	Distance ring	Distanzring 3	1
9	150362208	Bearing KR 6206	Rillenkugellager KR 6206	1
10	000244202	Bearing 6007 ZZ	Rillenkugellager 6007 ZZ	1
11	150008306	Bearing 6209	Rillenkugellager 6209	1
13	150163307	Screw M10x20 8.8	Cylinderschraube M10x20 8.8 Zn	4
14	000228300	Washer A10 Zn	Scheibe A10 Zn	4
16	150008404	Seal ring A38x62x10	Wellendichtring A38x62x10	1
18	000237407	Circlip 25	Sicherungsring 25	1
19	000237602	Circlip 35	Sicherungsring 35	1
20	000237906	Circlip 45	Sicherungsring 45	1
21	000236300	Circlip 62	Sicherungsring 45	1
22	000236603	Circlip 85	Sicherungsring 85	2
24	000256207	Cotter A8x7x36	Passfeder A8x7x36	1
25	000256305	Cotter A10x8x60	Passfeder A10x8x60	1

Bild 1 Fig 1

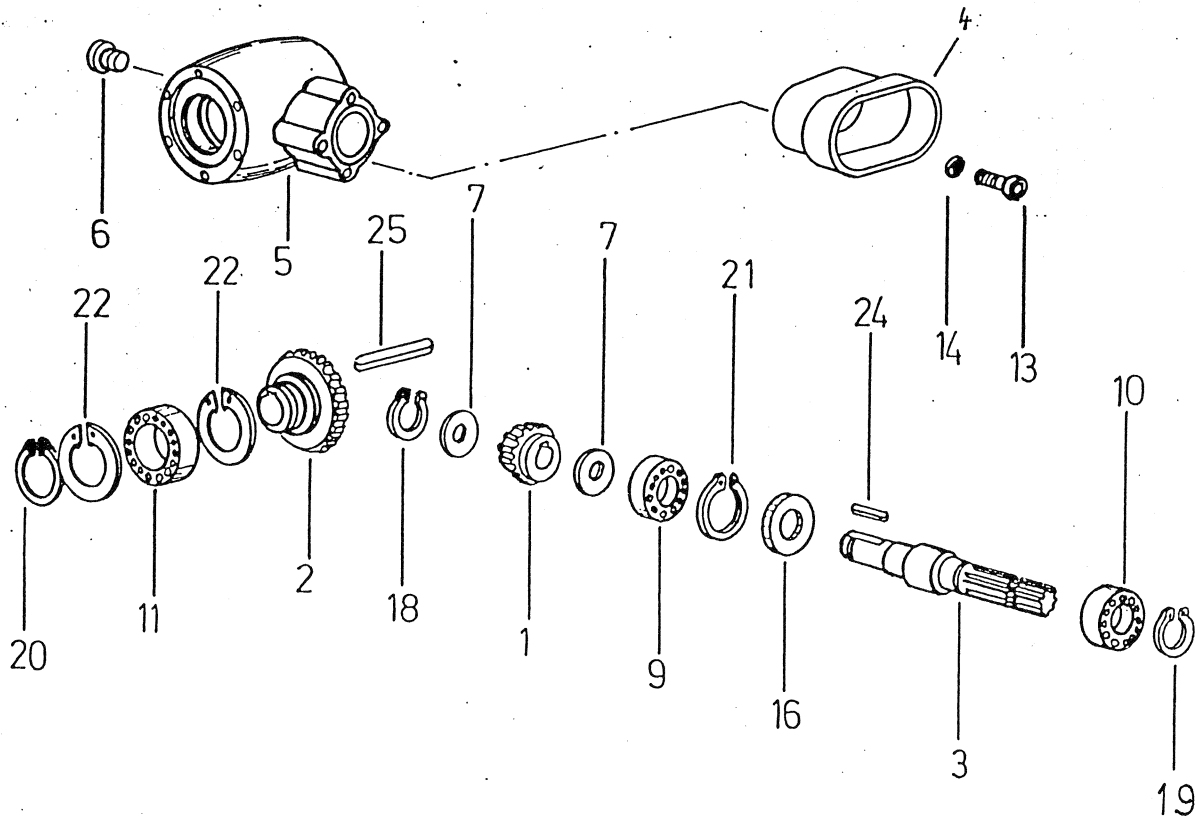

No. on the figure Numer anzeichn.	Catalogue no. Katalog nummer	Description	Benennung	Quantity Stück
1	152900115-337.02.015.1	Gear-box housing	Getriebegehäuse	2
2	151940403-337.02.001.0	Tube with a flange left	Rohr mit Flansche links	1
3	151941509-337.03.001.0	Tube with a flange right	Rohr mit Flansche rechts	1
4	154182404-337.02.020.0	Shaft left	Wellw links	1
5	154182501-337.03.010.0	Shaft right	Welle rechts	1
6	151941206-337.02.010.0	Rotor	Rotor	4
7	152725000-345.01.007.0	Shaft-joint 125	Gelenkkreuz	2
8	151040422-325.02.026.2	Pin welded	Hülse schw.	2
9	152725304-345.01.010.0	Gear	Zahnrad	2
10	151040803-325.02.030.0	Spring	Druckfeder	2
11	151752106-150.08.006.0	Distance washer	Distanzscheibe kpl.	2
12	151013708-TN 01	Distance ring 30,2/38	Distanzring 30,2/38	1
14	151946123-337.00.004.0	Holder	Träger	16
15	152870600-345.00.010.0	Spring finger	Federzinke	16
16	152954501-345.00.018.0	Safety device	Sicherung	24
19	150257304	Washer 13 Znr	Scheibe 13 Zn	24
20	151019908-TN 01	Washer	Scheibe	24
21	000211602	Screw M12x25 8.8	SK-Schraube M12x25 8.8	8
23	000248805	Screw M12x35 8.8 Zn	SK-Schraube M12x35 8.8 Zn	32
24	000203504	Screw M12x45 8.8 Zn	SK-Schraube M12x45 8.8 Zn	16
25	000210202	Screw M10x25 8.8 Zn	SK-Schraube M10x25 8.8	12
27	000250604	Nut M12 5 Cd	SK-Mutter M12 5 Cd	16
28	000221502	Nut M12 5 Zn	SK-Mutter 5 Un	32
29	000228300	Washer B10	Federring B10	12
30	000228603	Washer B12 Zn	Federring B12 Zn	32
31	000228505	Washer B12	Federring B12	8
32	000224509	Washer A12 Zn	Scheibe A12	2
33	150016306	Pin 4x24	Spannhülse 4x24	2
34	000244603	Bearing 6008 ZZ	Rillenkugellager 6008 ZZ	2
35	000244202	Bearing 6007 ZZ	Rillenkugellager 6007 ZZ	8
36	000236300	Circlip 62	Sicherungsring 62	12
37	000236408	Circlip 68	Sicherungsring 68	2
38	000237504	Circlip 30	Sicherungsring 30	2
39	150009001	Oil seal $\varnothing 30/\varnothing 52 \times 10$	Distungdring $\varnothing 30/\varnothing 52 \times 10$	2
40	000246905	Lubricator AM 10x1	Schmiemoppel A M10x1	2
41	000233802	Pin 6x55	Spannhülse 6x55	2

Bild 2 Fig 2

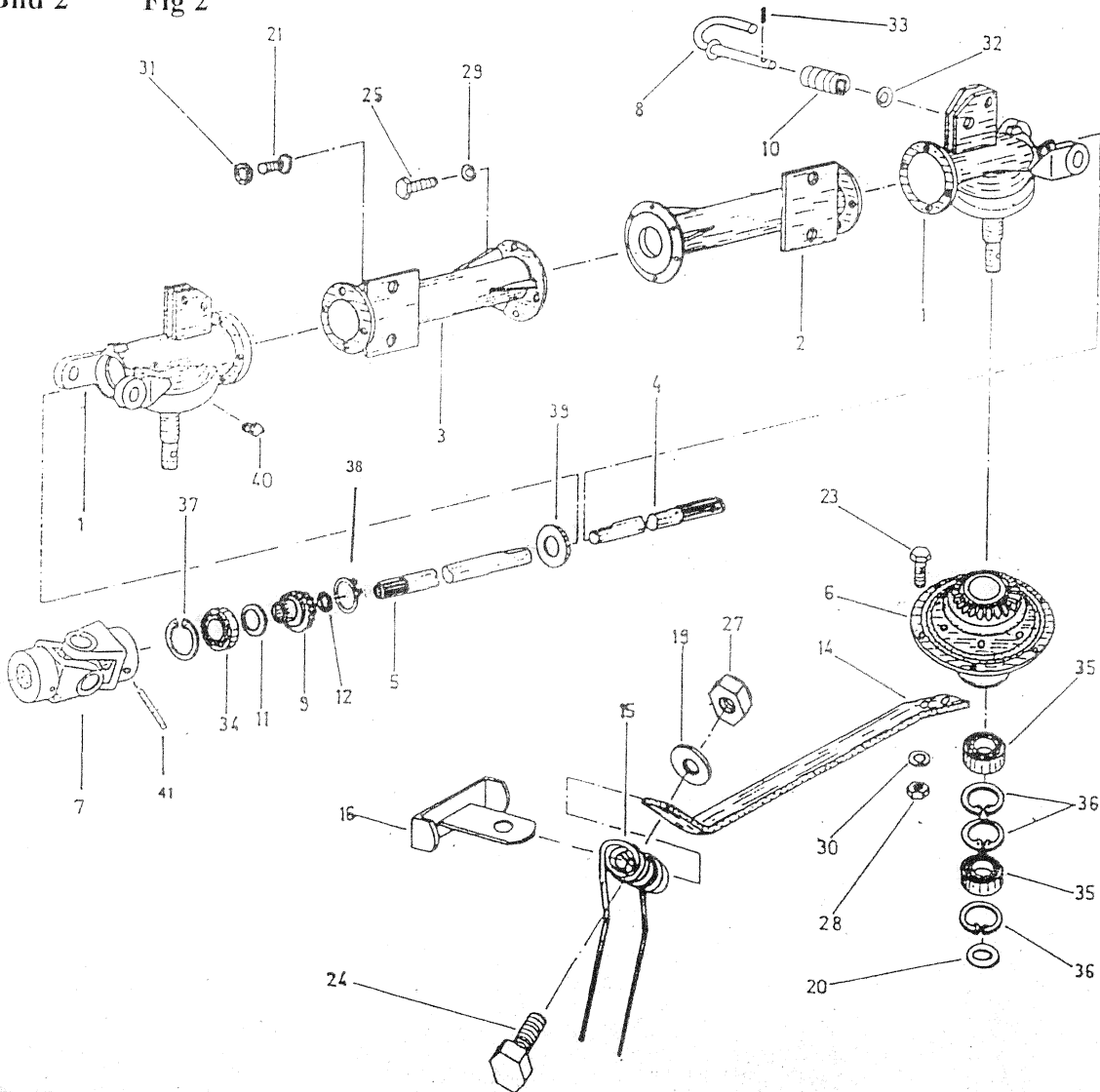

No. on the figure Numer anzeichn.	Catalogue no. Katalog nummer	Description	Benennung	Quantity Stück
1	151941901-337.04.001.0	Tube welded	Rohr Schw.	2
2	151797103-334.03.006.0	Gear-box housing	Getriebegehäuse	2
3	152726009-345.03.005.0	Fork	Gabel	2
4	151752106-150.08.006.0	Distance washer	Distanzscheibe kpl.	
5	154182609-337.04.010.0	Shaft	Welle	2
6	151950801-337.02.013.0	Gear	Zahnrad	2
8	151042204-325.04.008.0	Axle	Achse	2
9	151042302-325.04.009.0	Link	Verbindung	2
10	151042400-325.04.010.0	Bolt	Bolzen	2
11	151797602-334.03.010.0	Ring	Ring	2
12	151012905-TN 01	Distance ring 3 cpl.	Distanzring 3 kpl.	
13	151945300-337.11.000.0	Protection tube left	Schutz links Schw.	1
14	151945701-337.12.000.0	Protection tube right	Schutz rechts Schw.	1
15	151797906-334.00.001	Bolt welded	Bolzen Schw.	4
17	000243301	Bearing 6206 2Z	Rillenkugellager 6206 2Z	
18	000244603	Bearing 6008 2Z	Rillenkugellager 6008 2Z	2
19	000236408	Circlip 68	Sicherungsring 68	2
20	000237407	Circlip 25	Sicherungsring 25	2
21	000230707	Cotter A8x7x45	Passfeder A8x7x45	2
22	000235301	Pin 10x55	Spannhülse 10x55	2
23	000233802	Pin 6x55	Spannhülse 6x55	2
24	000208402	Screw M8x15 8.8	SK-Schraube M8x15 8.8	4
25	000210300	Screw M10x25 8.8 Zn	SK-Schraube M10x25 8.8 Zn	8
26	000211602	Screw M12x55 8.8	SK-Schraube M12x55 8.8	16
27	000228104	Washer B8	Federring B8	4
28	000228408	Washer B10 Zn	Federring B10 Zn	8
29	000225401	Washer 12	Scheibe 12	2
30	000228505	Washer B12	Federring B12	16
31	000251202	Nut M10 6 Zn	SK-Mutter M10 6 Zn	8
32	000238905	Cotter 4x25	Splint 4x25	4
33	000246905	Lubricator A M10x1	Schmiernippel A M10x1	2
34	150436102	Cover	Deckel	4

Bild 3 Fig. 3

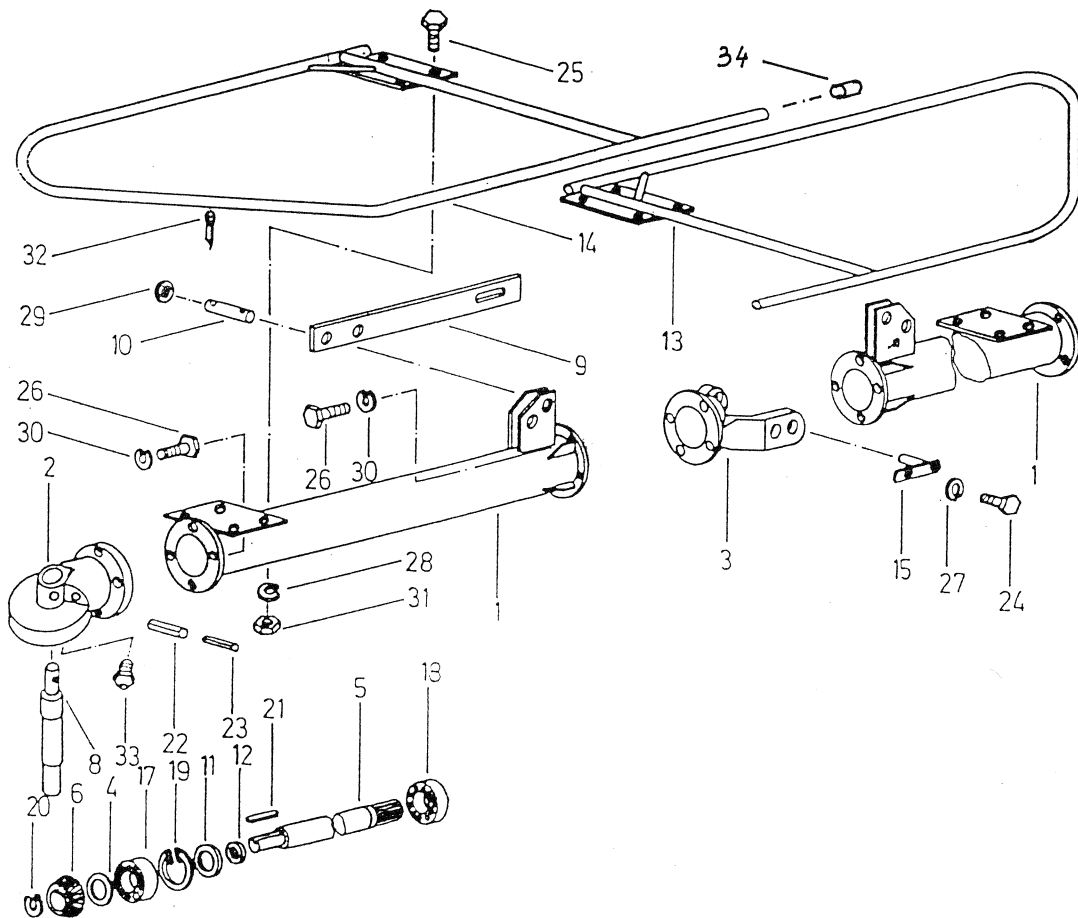

No. on the figure Numer anzeichn.	Catalogue no. Katalog nummer	Description	Benennung	Quantity Stück
1	151942508-337.05.000.0	Hitch welded	Anhängenrahmen Schw.	1
2	151943615-337.06.001.1	Axle left	Achse links Schw.	2
3	151944213-337.07.001.1	Axle right	Achse rechts Schw.	2
4	151944301-337.08.000.0	Wheel Bracket 1	Radkonsole 1	2
5	151945809-337.13.000.0	Wheel Bracket 2	Radkonsole 2	2
6	151944800-33709.000.0	Leg	Stützfuss	1
11	151688506-330.05.026.0	Pin	Hülse	2
12	151047806-220.00.001.0	Bolt	Bolzen	1
13	151048306-200.14.014.5	Screw with handle	Schraube	1
14	151048501-455.02.094.0	Wire safety clamp	Drahtsicherung	1
15	151381105-455.02.095.1	Spring	Druckfeder	2
16	153082309	Washer	Scheibe	4
17	151029407-200.07.005.5	Sleeve	Büchse elast.	2
18	150087202	Screw M12x25	SK Schraube M12x25	4
19	000228603	Washer B12	Scheibe B12	4
20	152378901-337.00.018.0	Handle	Griff	1
21	000255208	Bearing 6205 2Z	Rillenkugellager 6205 2Z	8
22	155472507	Cover	Deckel	4
23	000214306	Screw M16x40 8.8	SK-Schraube M16x40 8.8	4
26	000222100	Nut M16	Mutter M16	4
28	151006002	Washer	Scheibe	4
29	000228701	Washer B16	Federring B16	4
30	000232206	Pin 4x32	Spannhülse 4x32	1
31	000233704	Pin 6x50	Spannhülse 6x50	4
32	000235203	Pin 10x50	Spannhülse 10x50	4
33	150060908	Pin 10x70	Spannhülse 10x70	2
34	000237504	Circlip 30	Sicherungsring 30	4
35	000246601	Lubricator A M8x1	Schmiernippel A M8x1	4
36	152372202-337.16.000.0	Hitch welded	Authanhung Schw.	1
36	153686700-337.18.000.0	Hitch welded	Authanhung Schw.	1
37	151576609-327.03.028.0	Pivoting hitch	Anhangewippe kpl.	2
38	151576805-327.03.030.0	Bolt	Bolzen für Anhangewippe	2
39	151007922-510.02.054.0	Cover	Deckel	1
40	154047105-389.00.009.0	Support leg	Stützfuss	1
41	000239904	Sprocket 5x22	Splint 5x32	4
42	000232803	Pin 5x40	Spannhülse 5x40	1
43	150405207	Wheel cpl.15x6.00-6 4 PLY	Lauftrad kpl 15x6.00-6 4 PLY	4
44	150257700	Tyre 15x6.00-6 4 PR	Reifen 15x6.00- 4 PR	4
45	150257108	Pneumatic 15x6	Schlauch 15x6	4
46	150405305	Rim 4.50 A x 6	Felge 4.50 A x 6	4
47	152903807-516.02.015.0	Safety fuse	Sicherungsstift	1
48	153245714-342.00.015.1	Chain	Kette	1

Bild 4 Fig.4

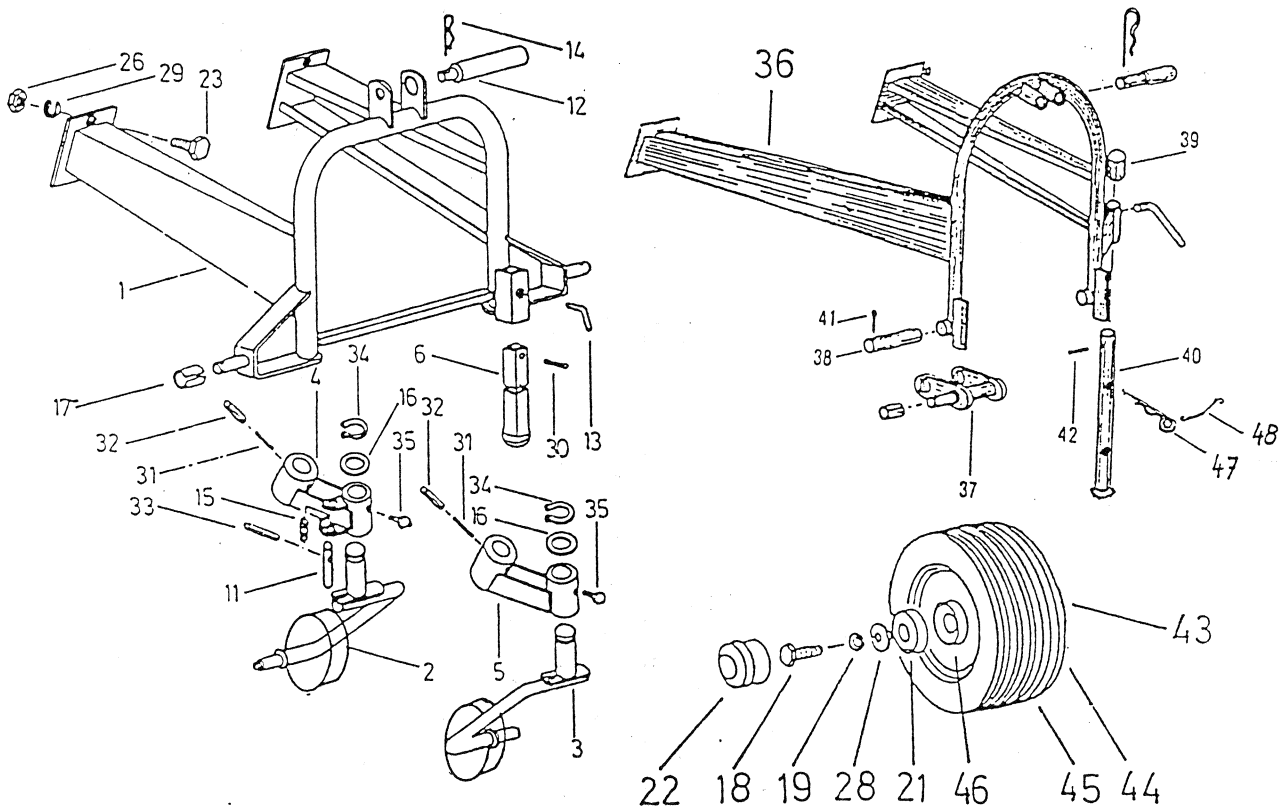

No.on the figure Numer anzeichn.	Catalogue no. Katalog nummer	Description	Benennung	Quantity Stück
1	151946602-339.05.001.0	Pull-Type hitch	Anschluss Schw.	1
2	151947709-339.05.014.0	Hitch plate left	Anschlussplatte links	1
3	151948209-339.05.021.0	Hitch plate right	Anschlussplatte rechts	1
4	151948307-339.05.023.0	Bolt welded	Bolzen Schw.	1
5	151948502-339.05.026.0	Spandle welded	Spindel Schw.Büchse	1
6	151948806-33905.031.0	Sleeve	Büchse	2
7	151027105-510.05.054.0	Bolt	Bolzen	2
8	151048501-455.02.094.0	Wire safety clamp	Drahtsicherung	1
9	151233702-TN 01	Washer	Scheibe	6
10	151068604-11.23.048.5	Handle	Kanne	1
11	151949002-339.06.001.0	Axle left welded	Achse links Schw.	2
12	151949306-339.07.001.0	Axle right welded	Achse rechts Schw.	2
13	151044809-325.06.005.0	Rim with hole	Felge mit Ventilöffnung	4
14	151044907-325.06.006.0	Rim	Felge	4
15	151045005-TN 01	Sleeve	Büchse	4
16	151045103-592.05.002.0	Sleeve	Büchse	4
17	150156609	Tyre 3,50-6	Riften 3,50-6	4
18	150156707	Pneumatic 3,50-6	Luftschlauch 3,50-6 mit kurzem Ventil	4
19	000228202	Washer B8 Zn	Federring B8	16
20	150100606	Washer 14 tip 1 Zn	Scheibe R 14 St. tip 1 Zn	4
21	000228701	Washer B16	Federring B16	4
22	000220709	Nut M8 5 Zn	SK-Mutter M8 5 Zn	16
23	000250604	Nut M12 5 Cd	SK-Mutter M12 5 Cd	4
24	000222100	Nut M16 8	SK-Mutter M16 8	4
25	150040208	Screw M8x15	SK-Schraube M8x15 5.6	16
26	000214306	Screw M16x40	SK-Schraube M16x40 8.8	4
27	000255208	Bearing 6205 2 Z	Rillenkugellager 6205 2 Z	8
28	000241802	Rivet 6x20	Niet 6x20	1
29	000239904	Cotter 5x32	Splint 5x32	2
30	000246601	Lubricator A M8x1	Schmiernippel A M8x1	1
31	000232402	Pin 5x24	Spannhülse 5x24	1
32	000233303	Pin 5x32	Spannhülse 6x32	2
33	000233704	Pin 6x50	Spannhülse 6x50	4
34	000235203	Pin 10x50	Spannhülse 10x50	4
35	150294602	Wheel epl. 15x6.00-6 4 PLY	Lauftrad kpl 15x6.00-6 4 PLY	4
36	150257000	Tyre 15x6.00-6 4PR	Reifen 15x6.00-6 5 PR	4
37	150257108	Pneumatic 15x6	Schlauch 15x6	4
38	150260309	Rim 4.00x6 kpl.	Felge 4.00x6 kpl.	4

Bild 5 Fig.5

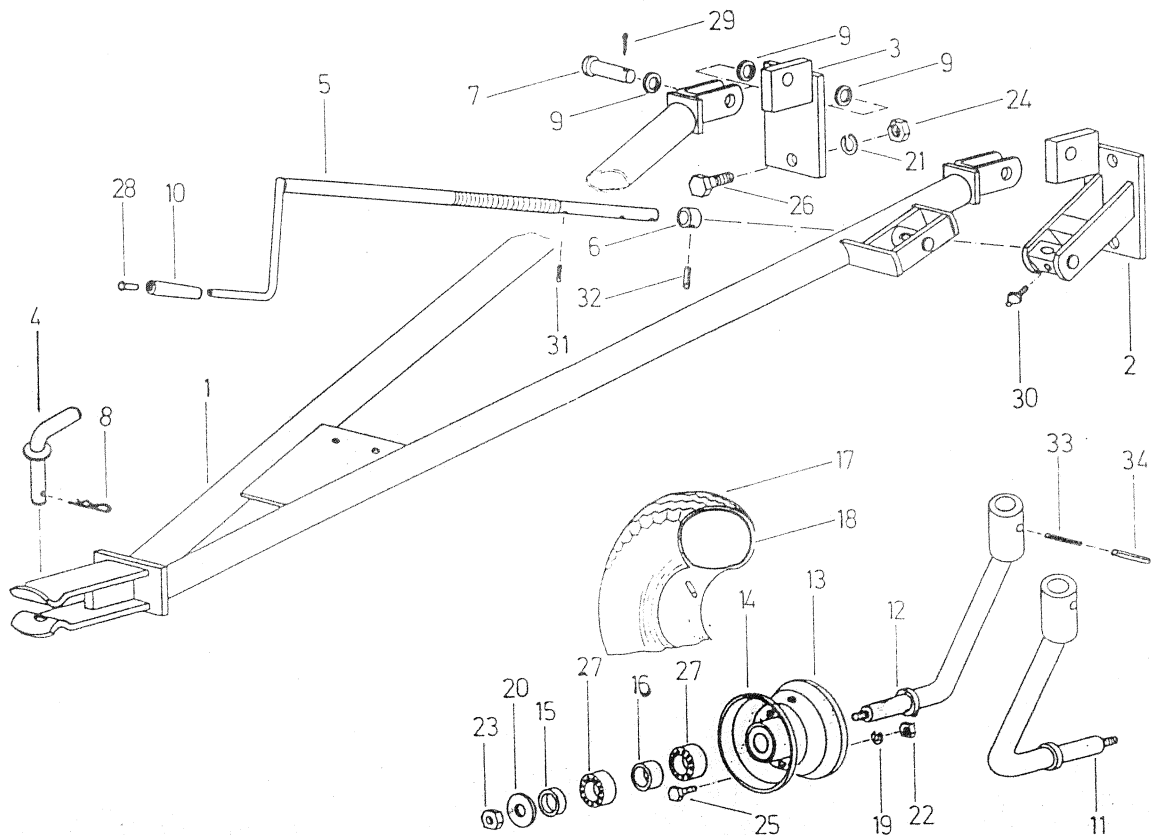

No.on the figure Numer anzeichn.	Catalogue no. Katalog nummer	Description	Benennung	Quantity Stück
1	151946602-339.05.001.0	Pull-Type hitch	Anschluss Schw.	1
2	151947709-339.05.014.0	Hitch plate l.	Anschlussplatte links	1
3	151948209-339.05.021.0-	Hitch plate r.	Anschlussplatte rechts	1
4	151948307-339.05.023.0	Bolt welded	Bolzen Schw.	1
5	151948502-339.05.026.0	Spindle	Spindel Schw.	1
6	151948806-339.05.031.0	Sleeve	Büchse	2
7	151027105-510.05.054.0	Bolt	Bolzen	2
8	151048501-455.02.094.0	Wire safety clamp	Drahtsicherung	1
9	151233702-TN 01	Washer	Scheibe	6
10	151068604-11.23.048.5	Handle	Kanne	1
11	151943615-337.06.001.1	Axle left welded	Achse links Schw.	2
12	151944213-337.07.001.1	Axle right welded	Achse rechts Schw.	2
13	151944301-337.08.000.0	Wheel bracket 1	Radkonsole 1	2
14	151945809-337.13.000.0	Wheel bracket 2	Radkonsole 2	2
17	155472507	Cover	Deckel	4
18	150087202	Screw M12x25	SK-Schraube M12x25	4
19	151688506-330.05.026.0	Pin	Hülse	2
20	151381105-455.02.095.1	Spring	Druckfeder	2
21	153082309	Washer	Scheibe	4
22	151029407-200.07.005.5	Sleeve	Büchse elast.	2
23	000228603	Washer B12	Federring B12	4
24	151006002	Washer	Scheibe	4
25	152378901-337.00.018.0	Handle	Griff	2
26	000255208	Bearing	Rillenkugellager 6205 2 Z	8
30	000222100	Nut M16	SK-Mutter M16	4
33	000228701	Washer B16	Federring B16	4
34	000233704	Pin 6x50	Spannhülse 6x50	4
35	000235203	Pin 10x50	Spannhülse 10x50	4
36	150060908	Pin 10x70	Spannhülse 10x70	2
37	000214306	Screw M16x40 8.8	SK-Schraube M16x40 8.8	4
38	000237504	Circlip 30	Sicherungsring 30	4
39	000246601	Lubricator A M8x1	Schmiernippel A M8x1	6
40	150405207	Wheel cpl. 15x6.00-6 4 PLY	Laufrad kpl. 15x6.00-6 4 ply	4
41	150257700	Tyre 15x6.00-6 4 PLY	Reifen 15x6.00-6 4 PR	4
42	150257108	Pneumatic 15x6	Schlauch 15x6	4
43	150405305	Rim 4,50 A x 6	Felge 4,50 A x 6	4

Bild 6 Fig.6

