

- (SLO) Seznam nadomestnih delov  
(HR) Spisak rezervnih delov  
(GB) Spare parts list  
(D) Ersatzteilliste

- (I) Lista parti di ricambio  
(F) Liste des pièces de rechange



# SIP

# OPTICUT 220F

diskasti rotacijski kosilnik  
diskasta rotaciona kosačica  
falciatrice a disco rotante

rotary disc mower  
scheibenmähwerke  
faucheuse à disque rotatif

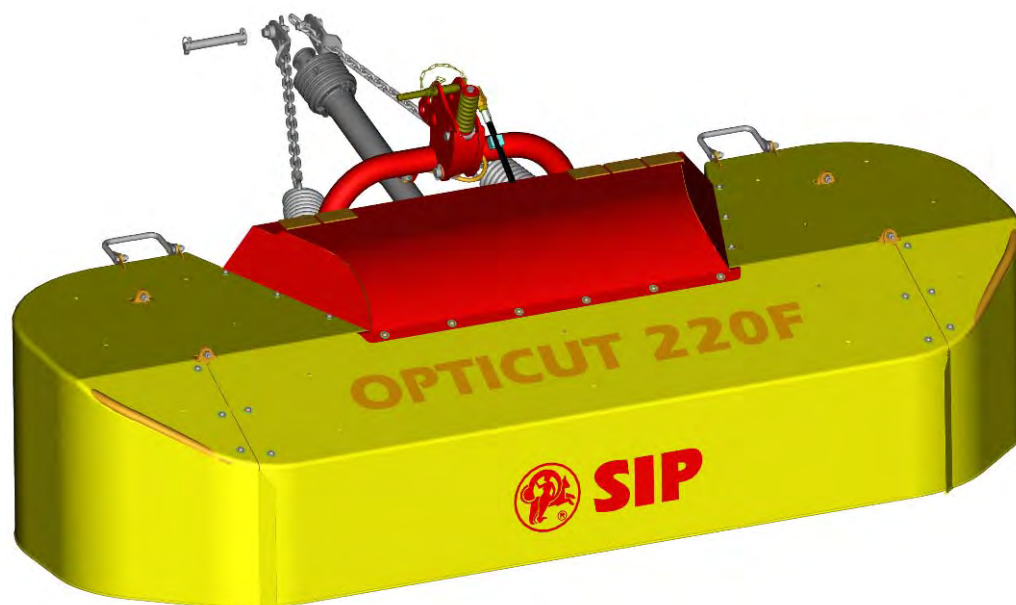

Velja od tov. št. dalje:  
Važi od tvor. broja dalje:  
Ab masch. Nr.:  
From mach Nr.:  
Da macch. Nr.:  
N° de machine:

OPTICUT 220 F = 151



STROJNA INDUSTRIJA d.d.  
3311 Šempeter v Savinjski dolini  
Slovenija

Tel: +386(03) 7038 500  
Fax: +386(03) 7038 663  
+386(03) 7038 674

158461504

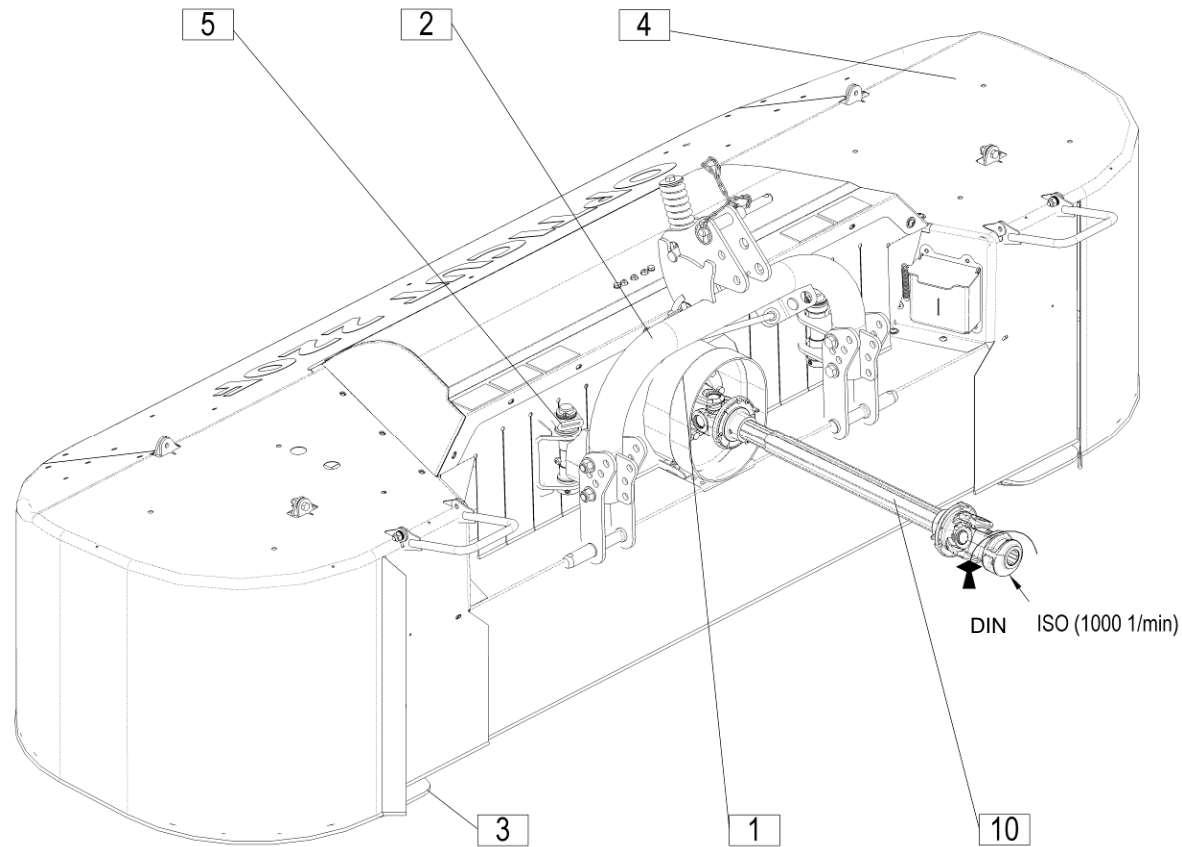



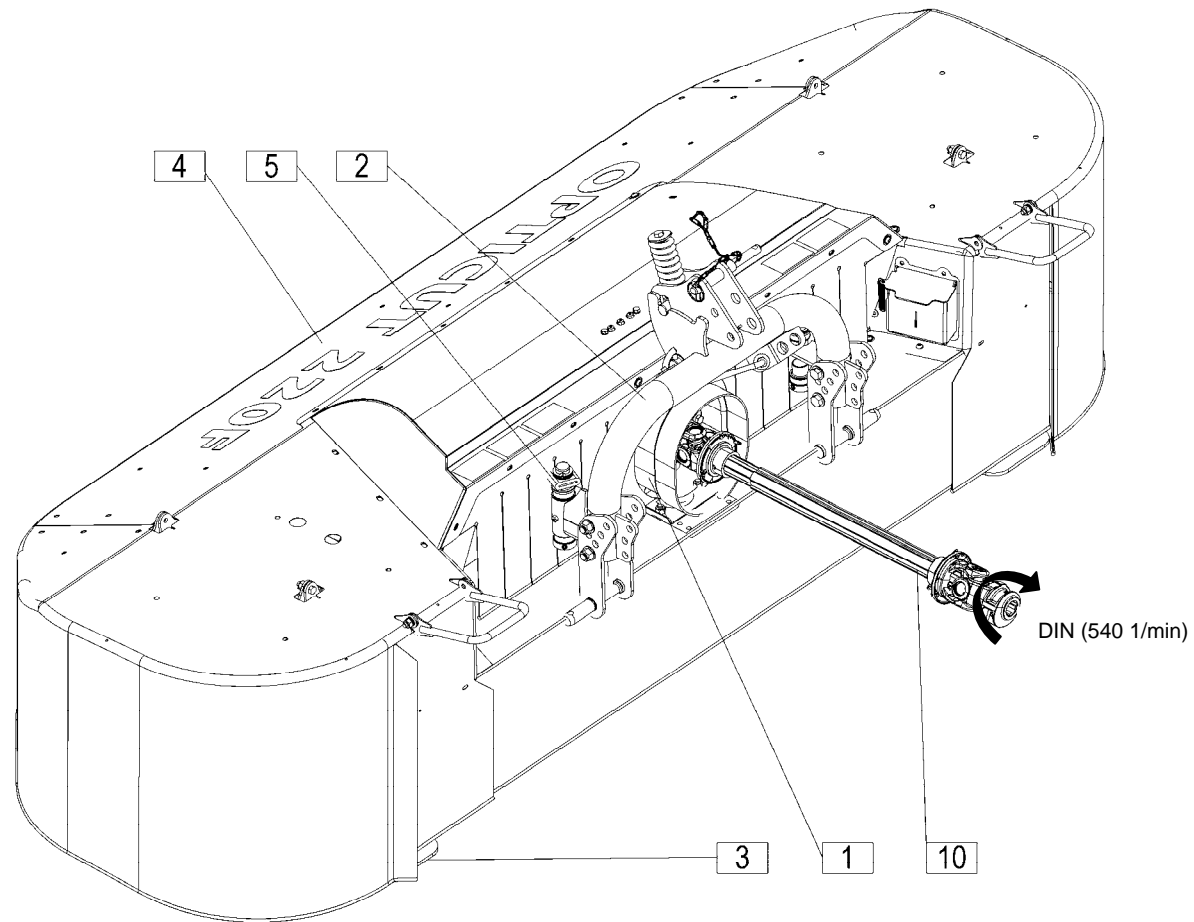



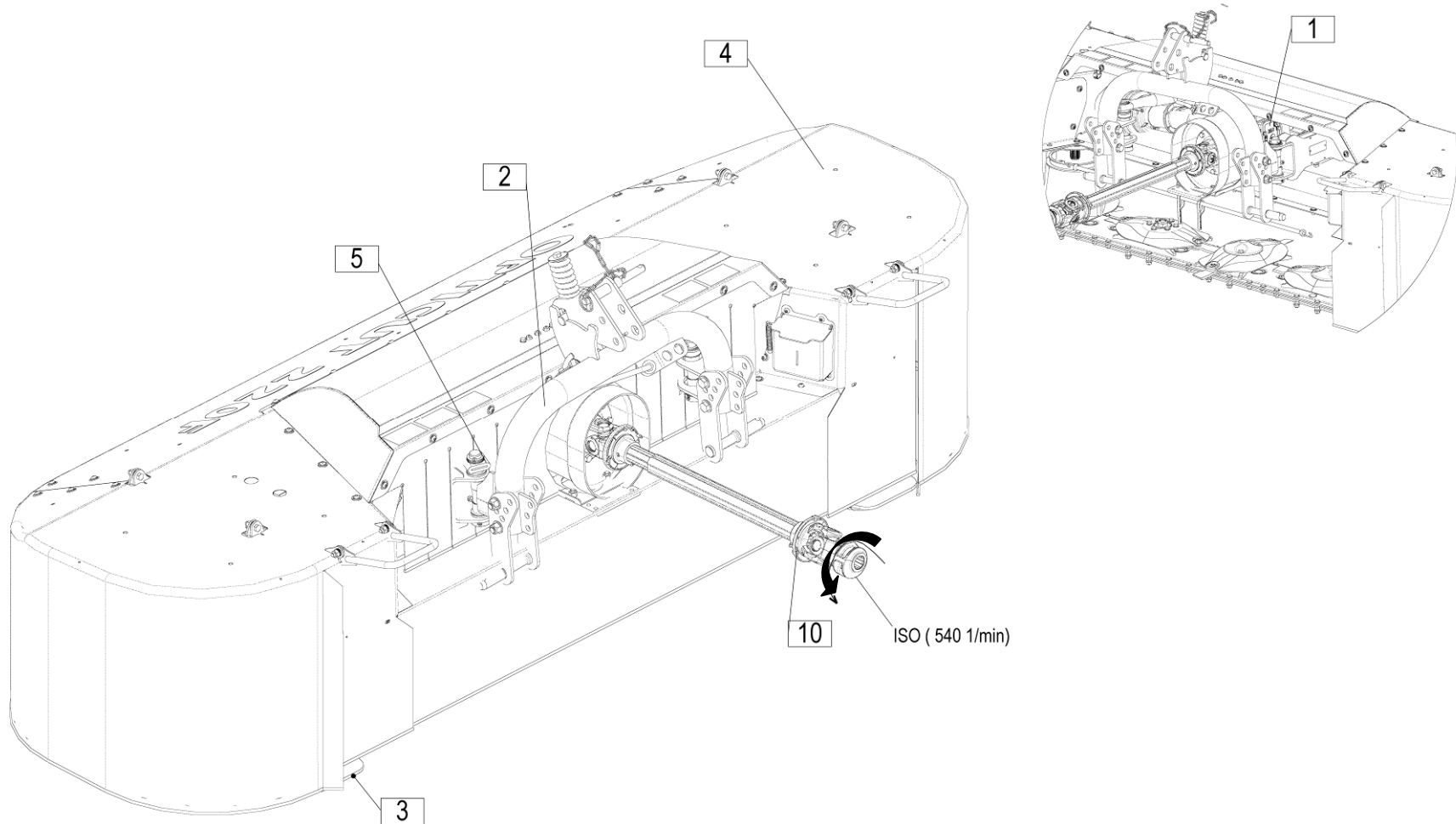



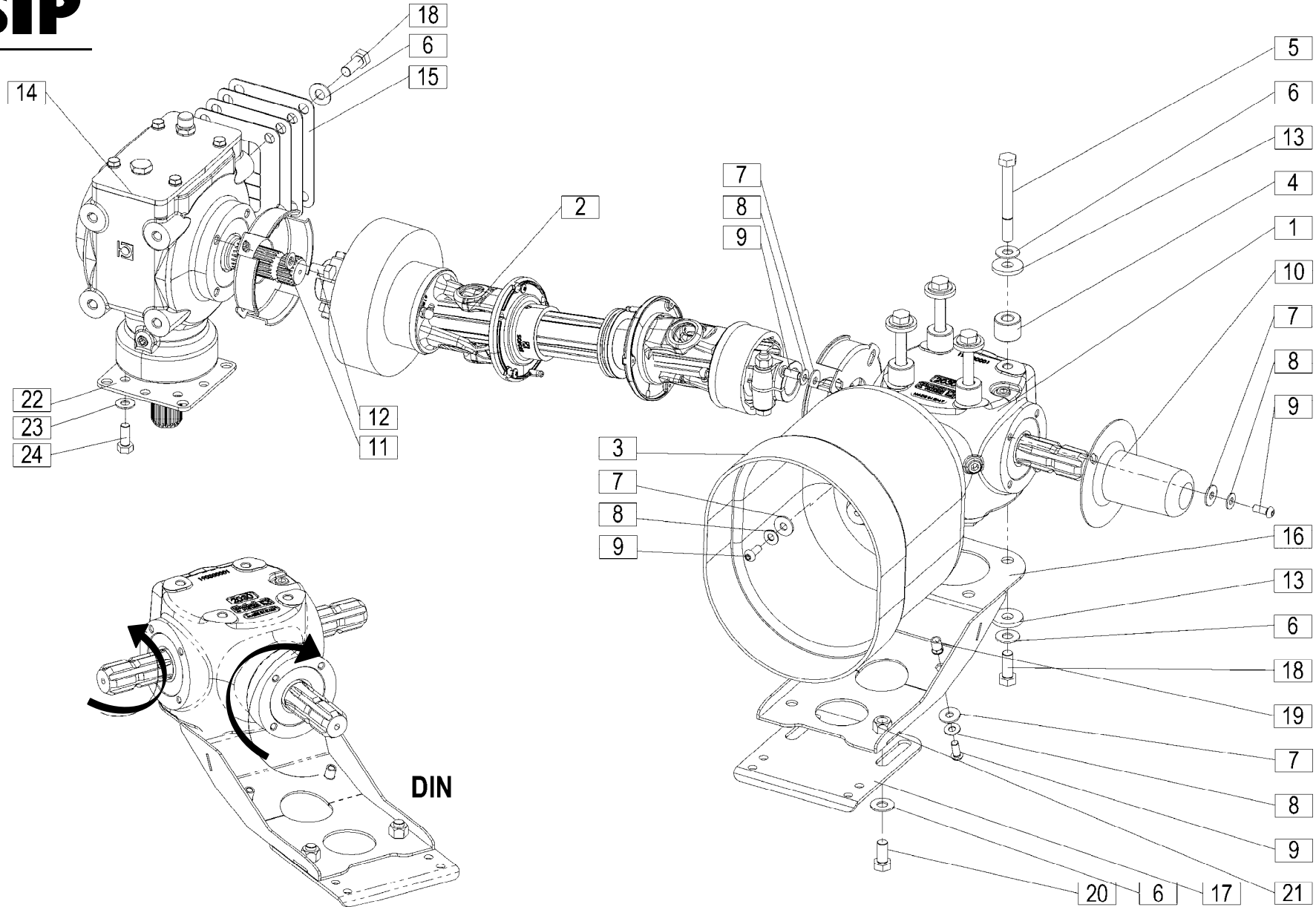





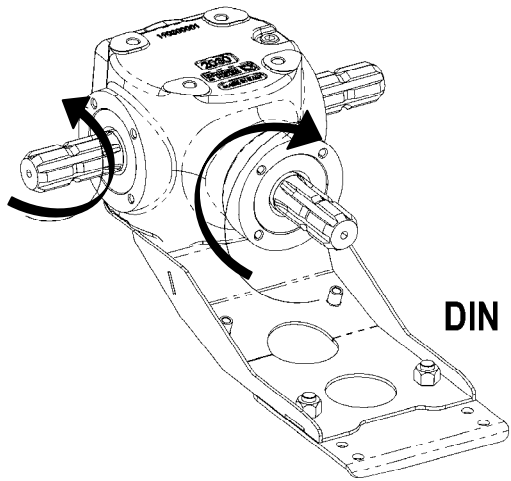
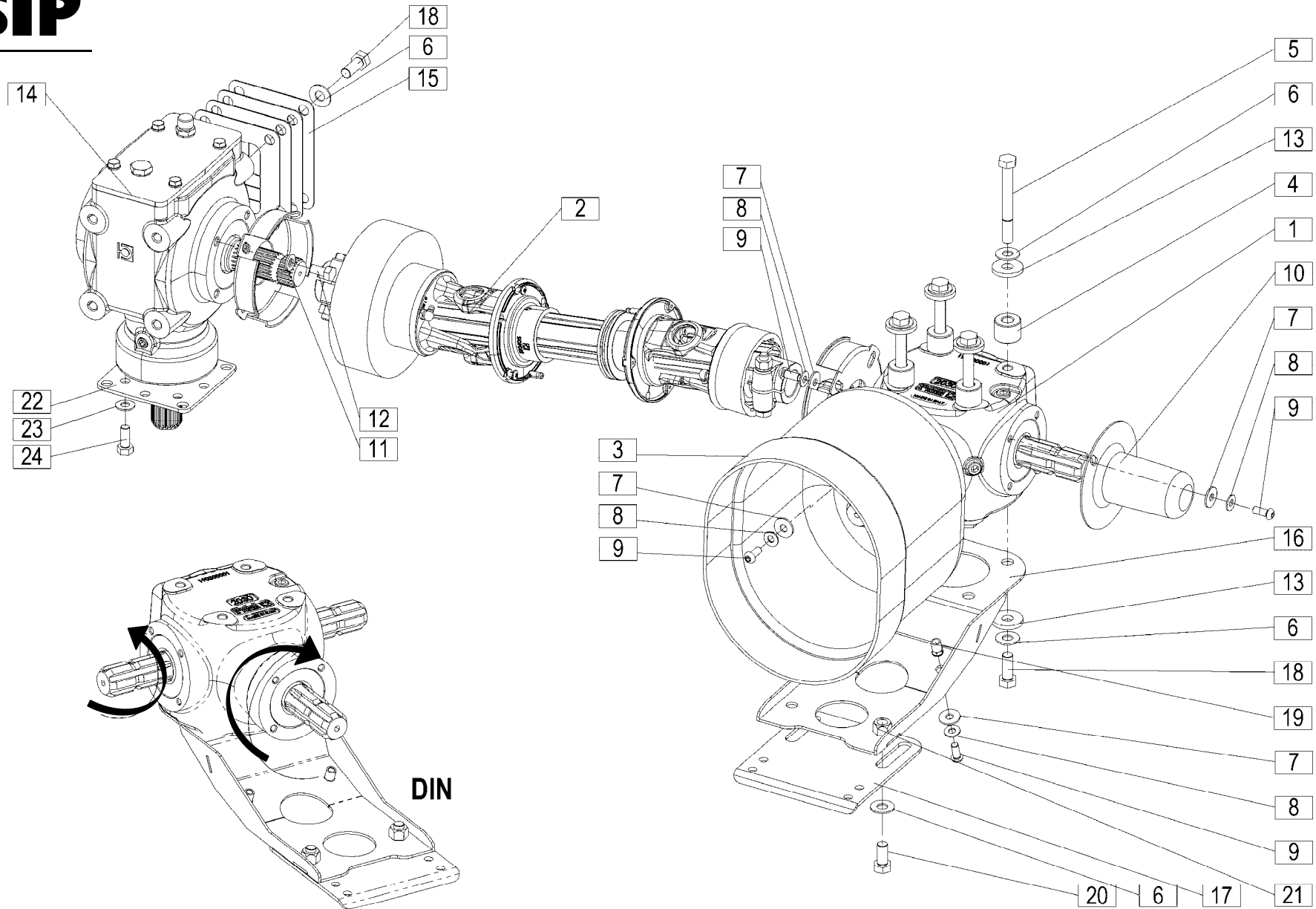



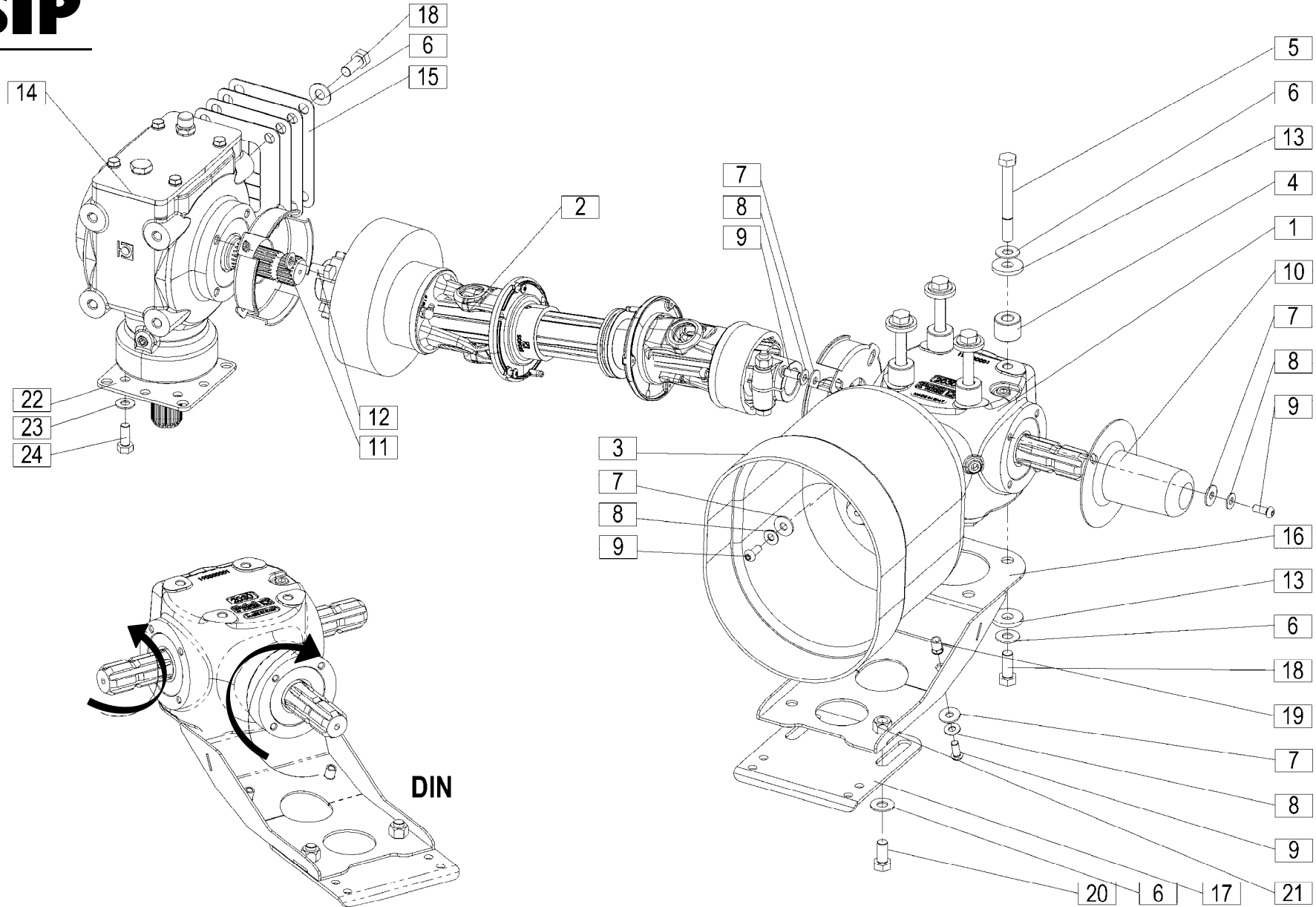



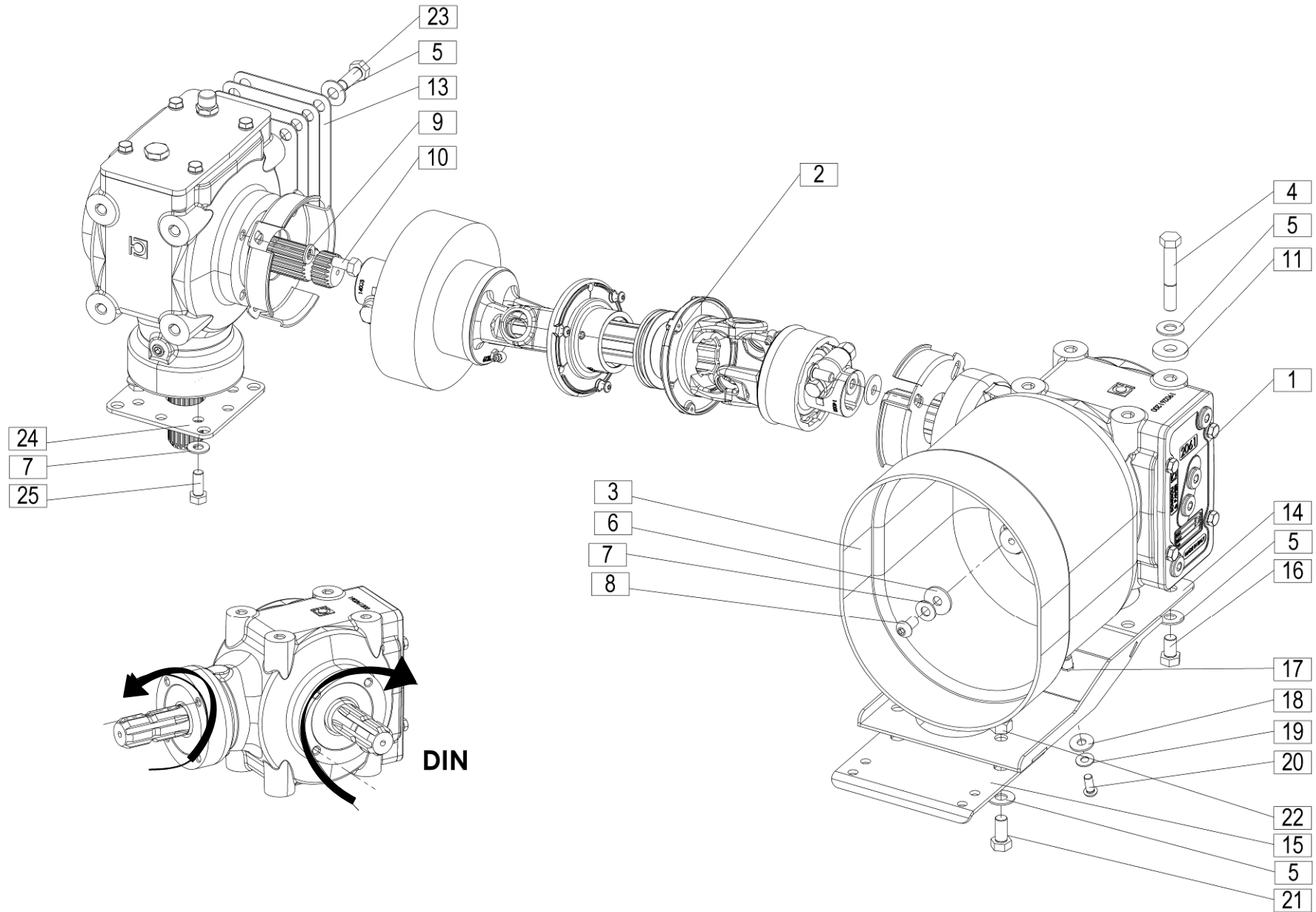



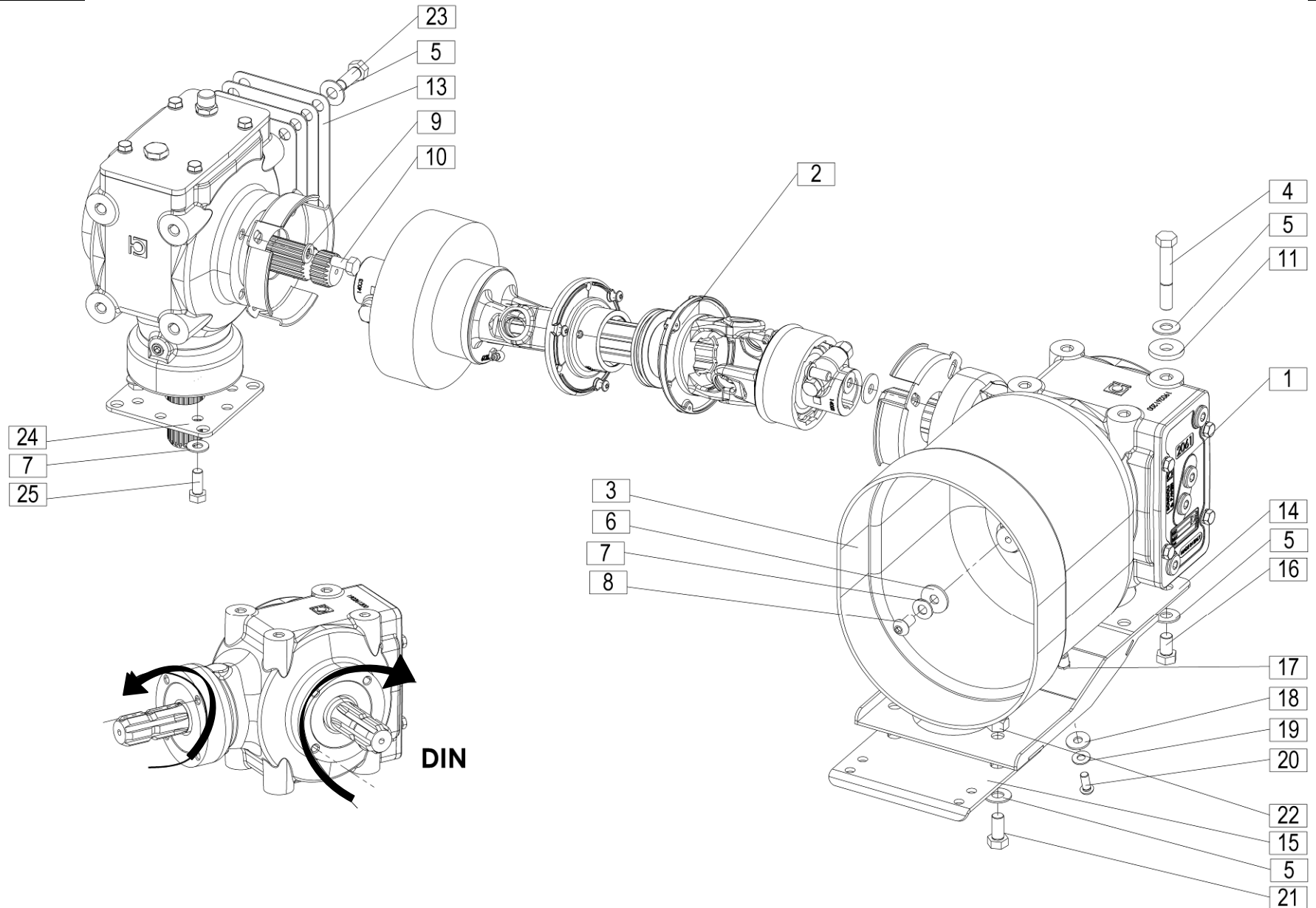





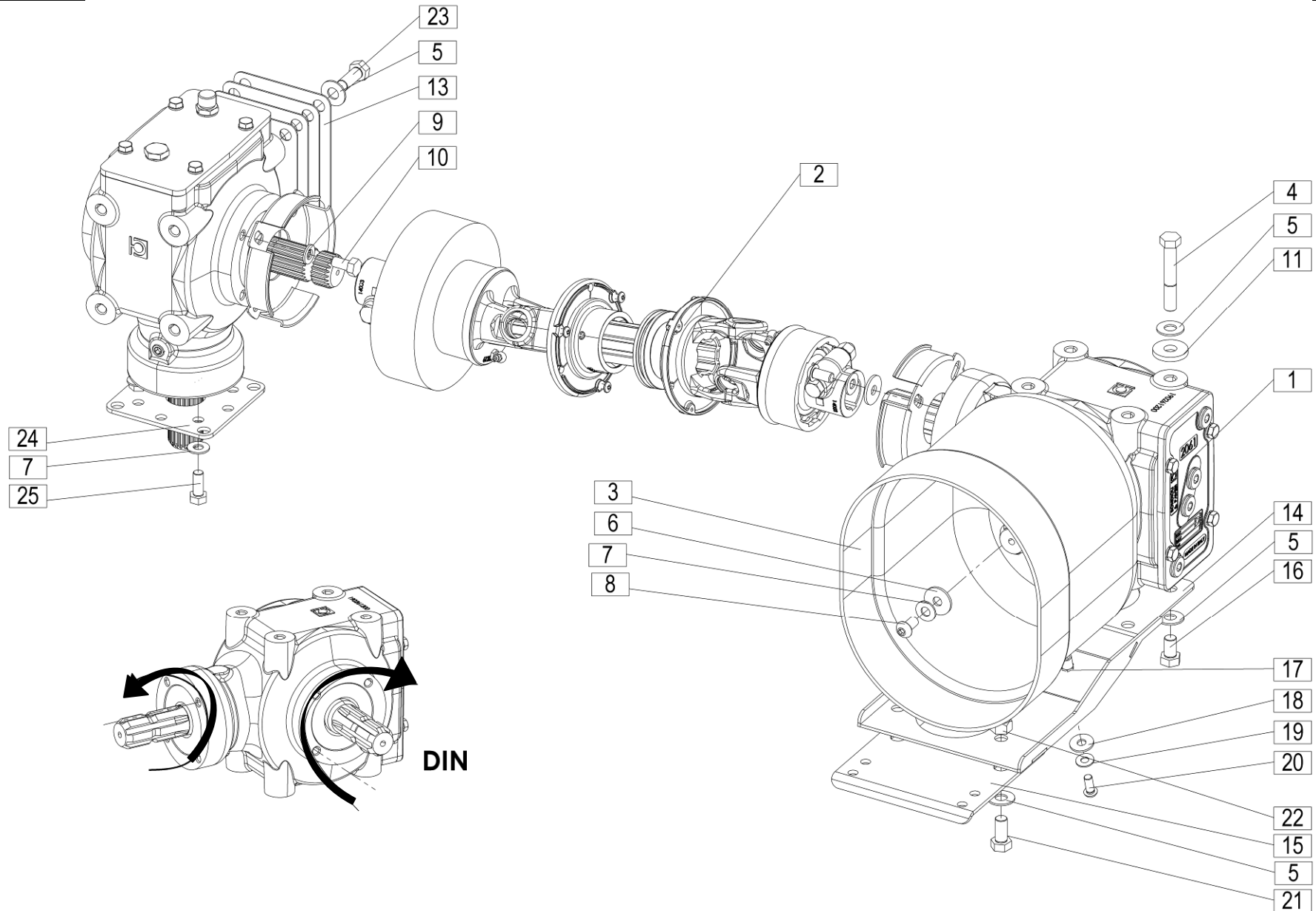



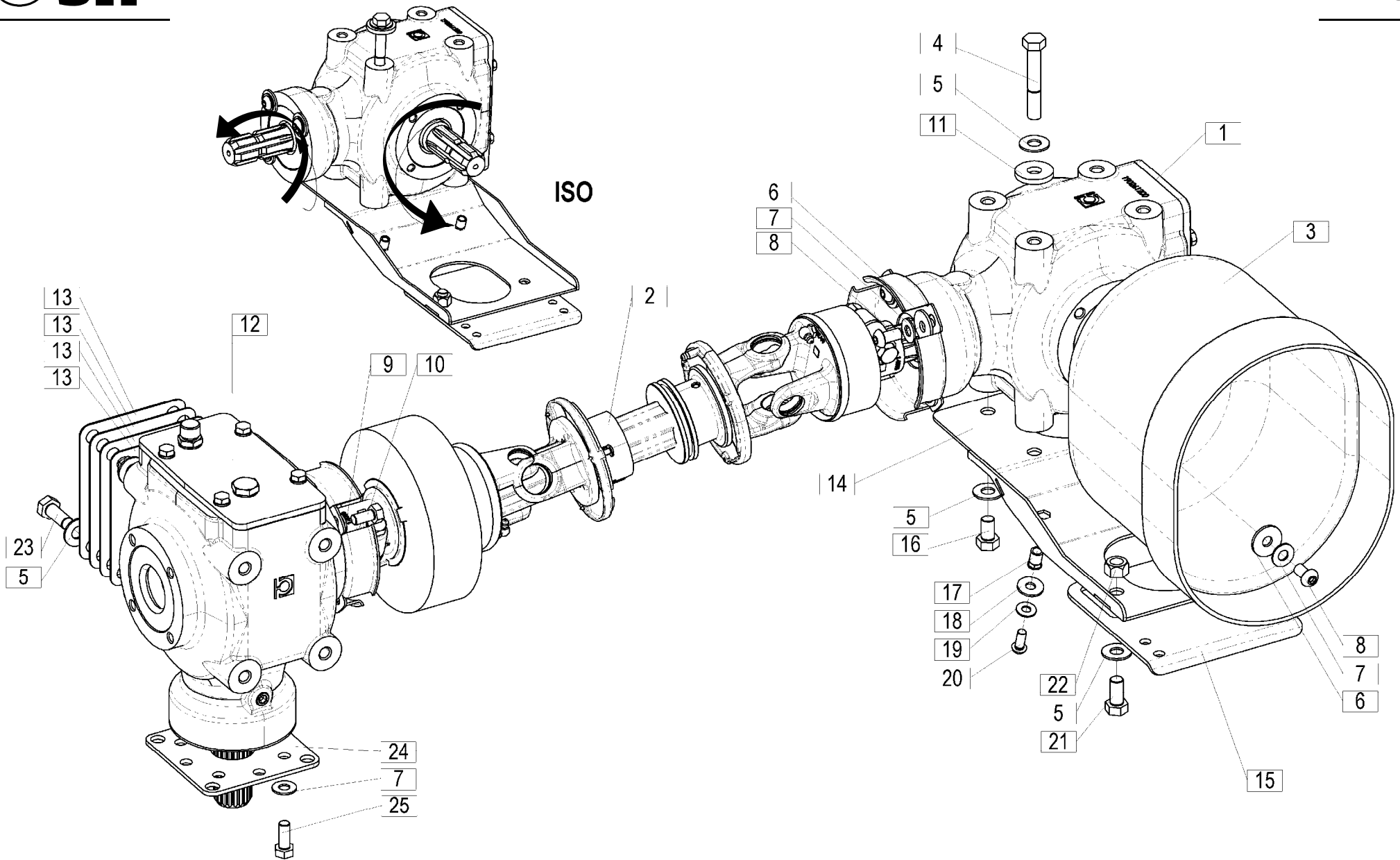



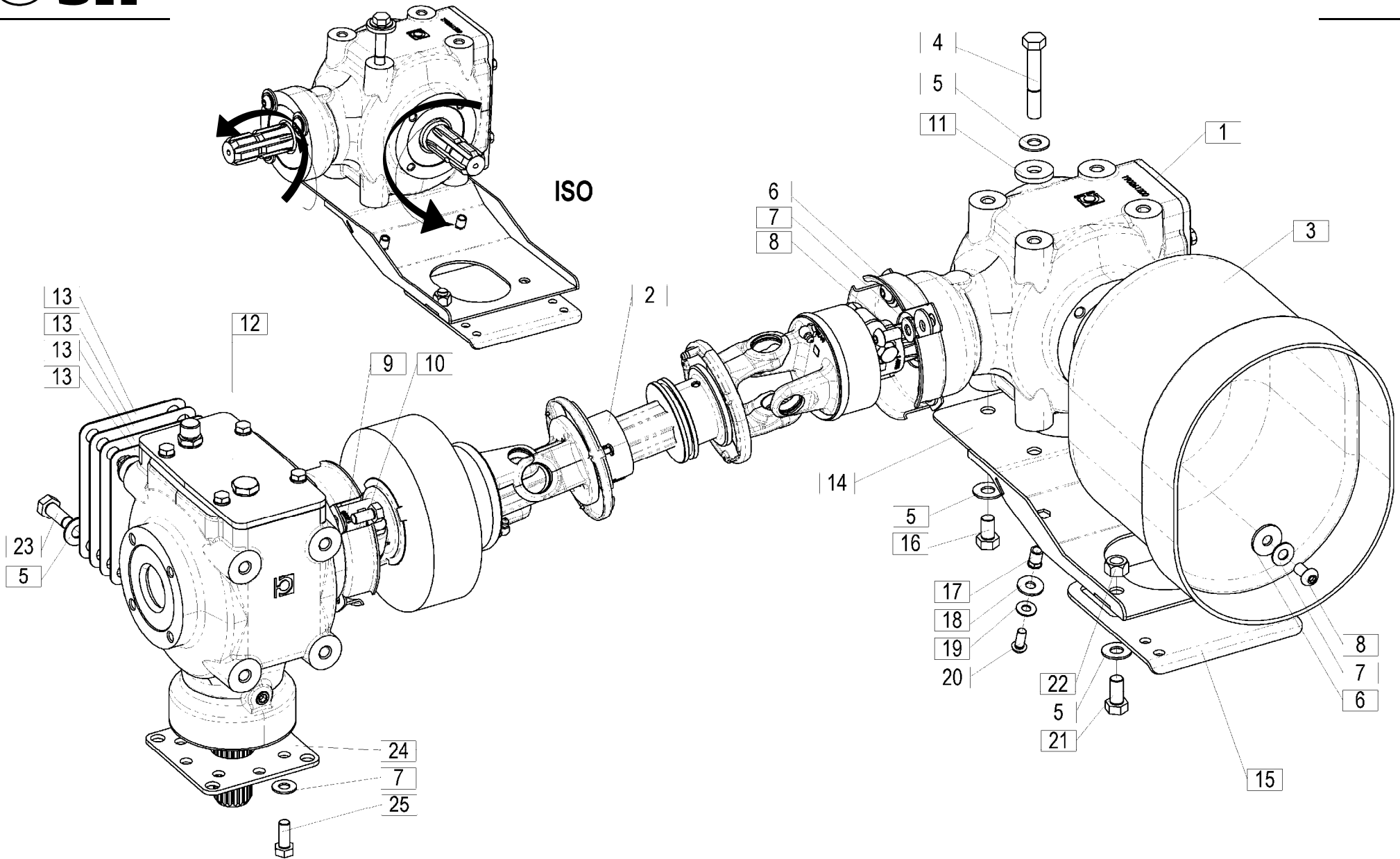



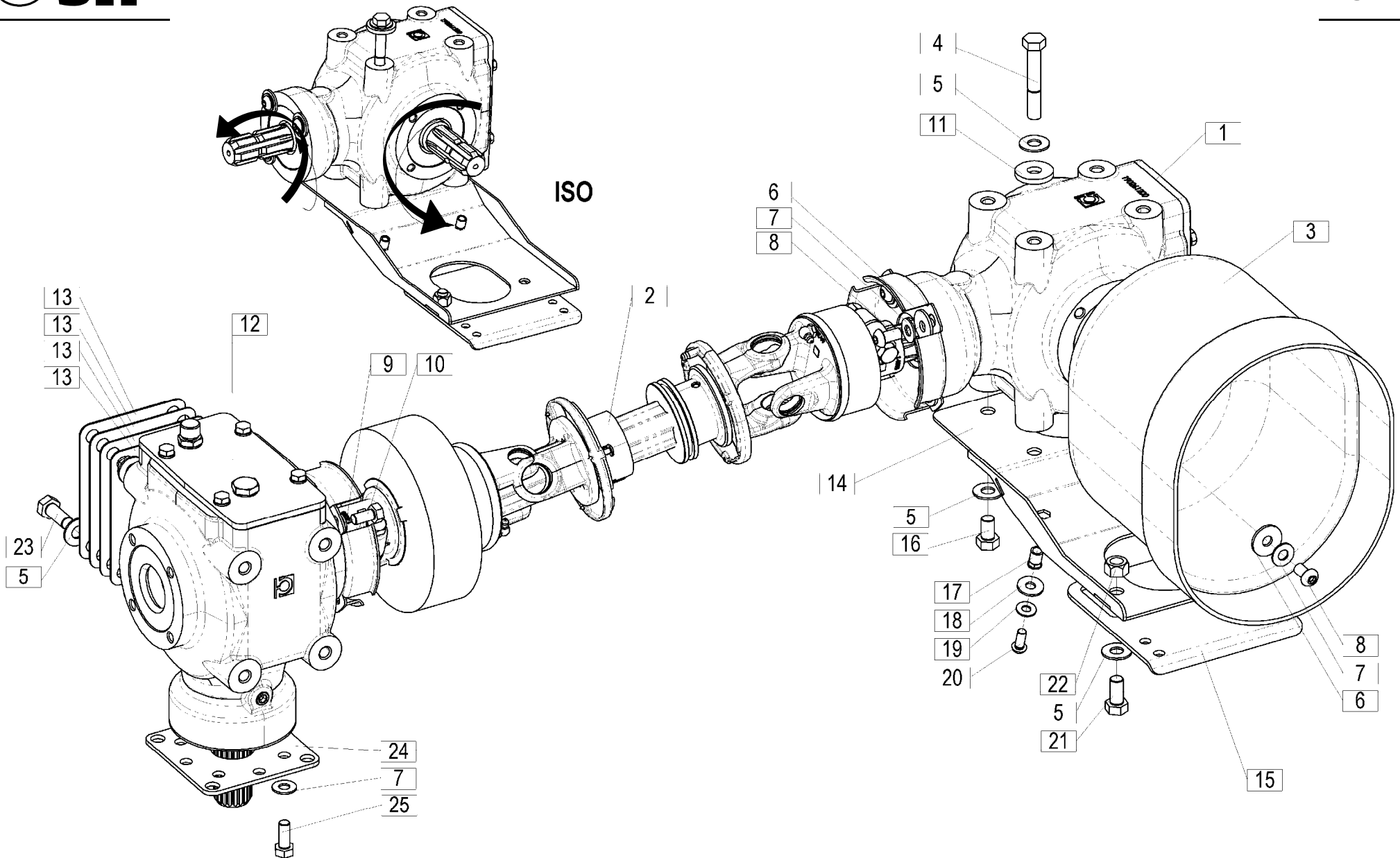





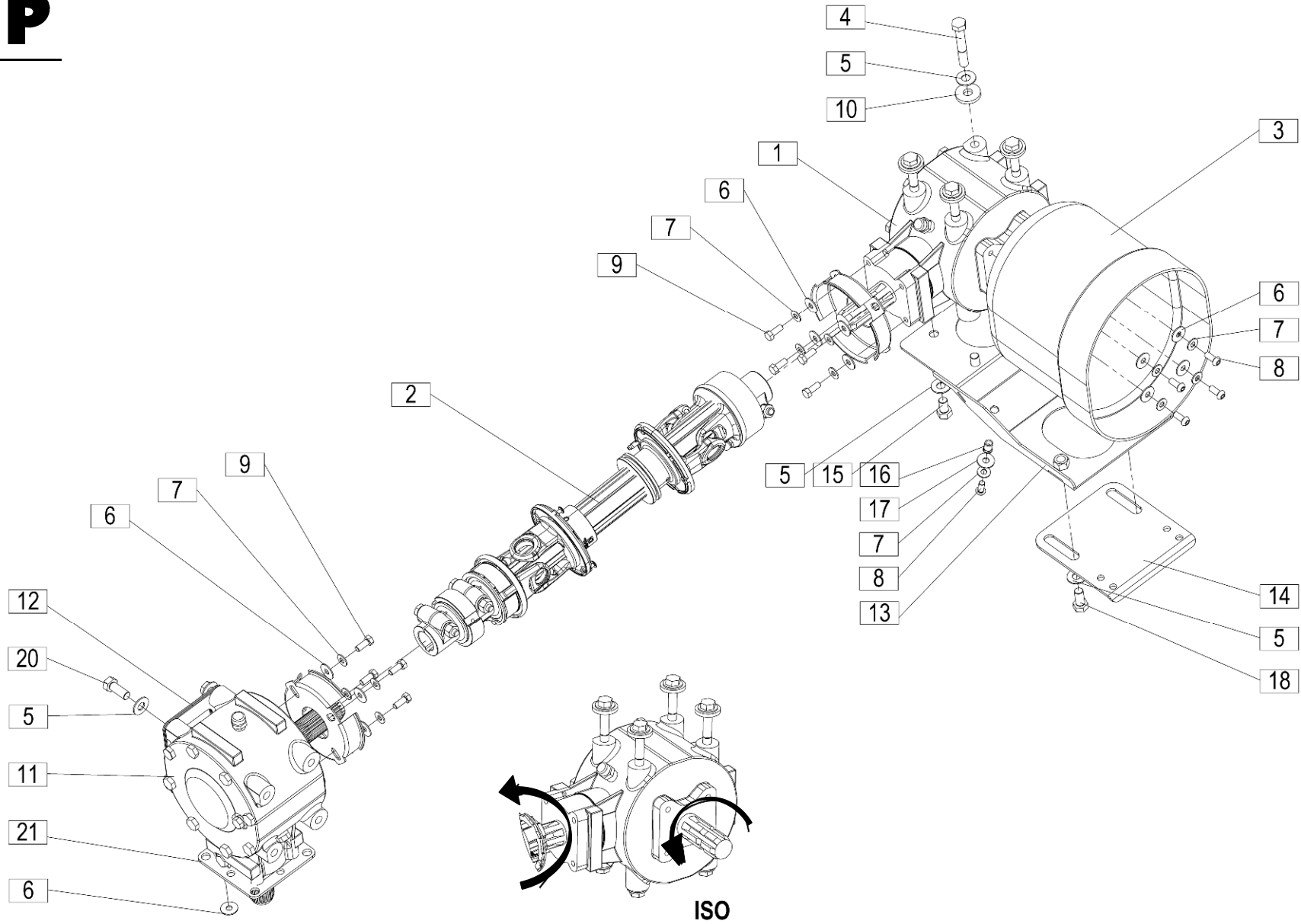



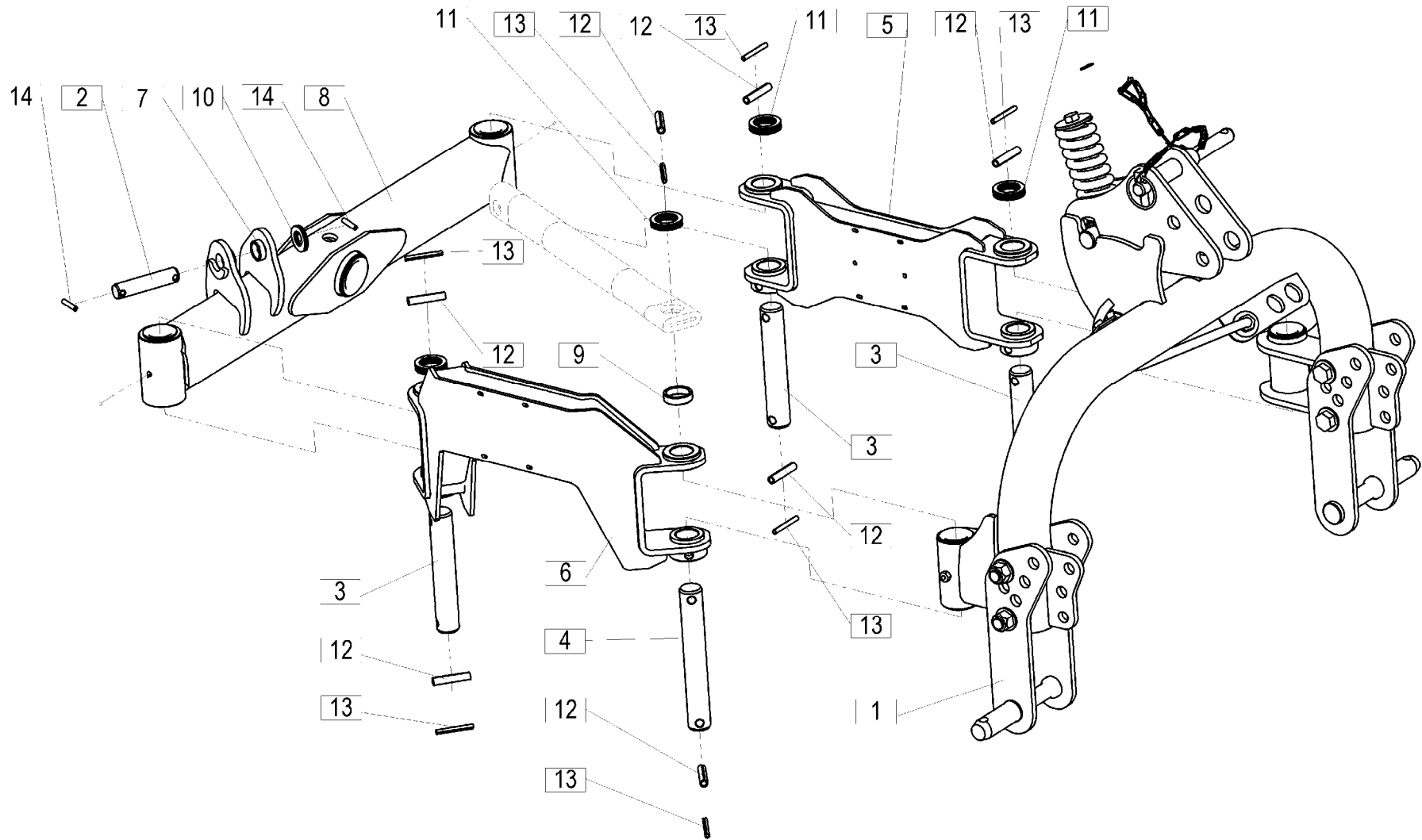



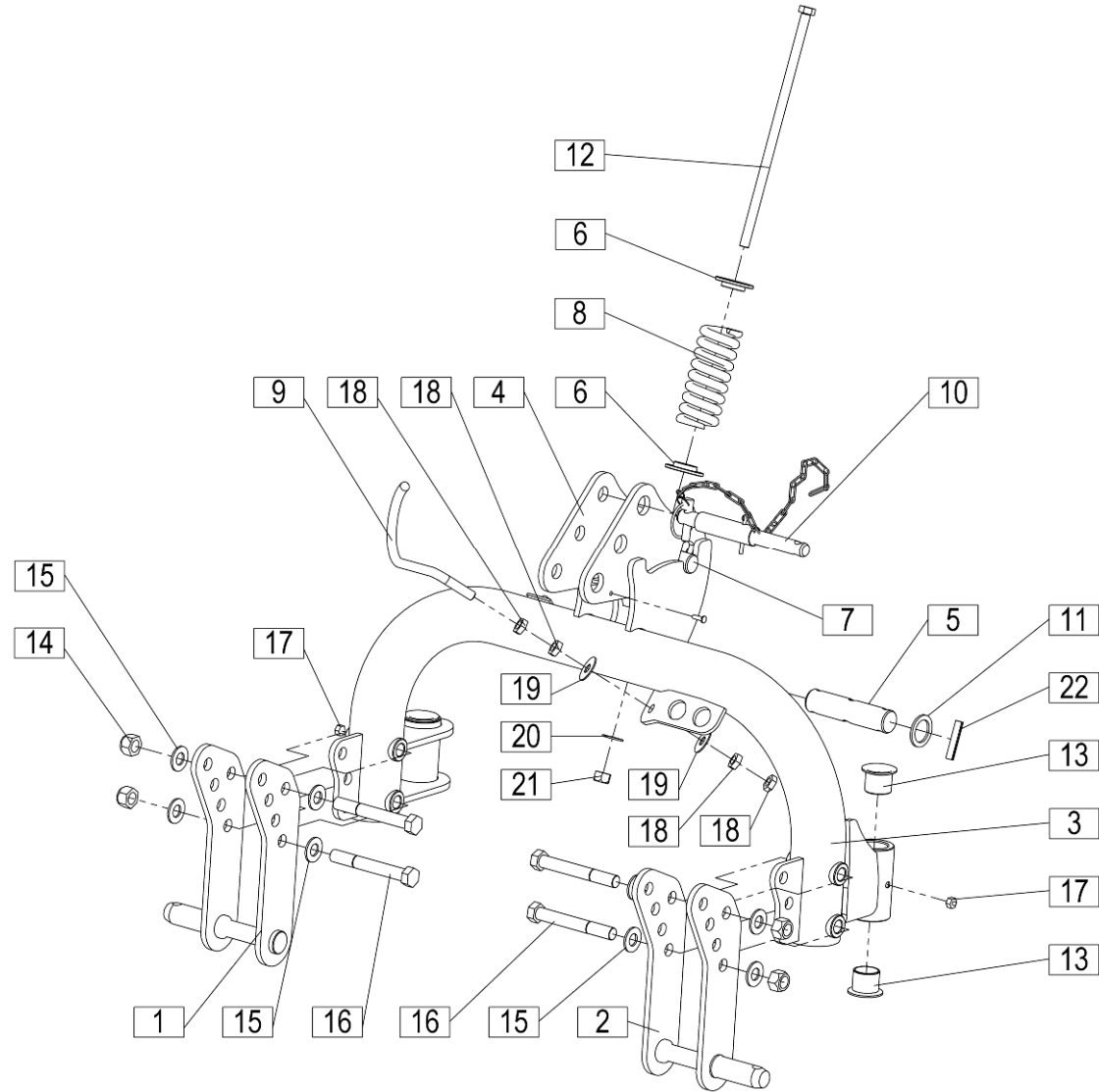



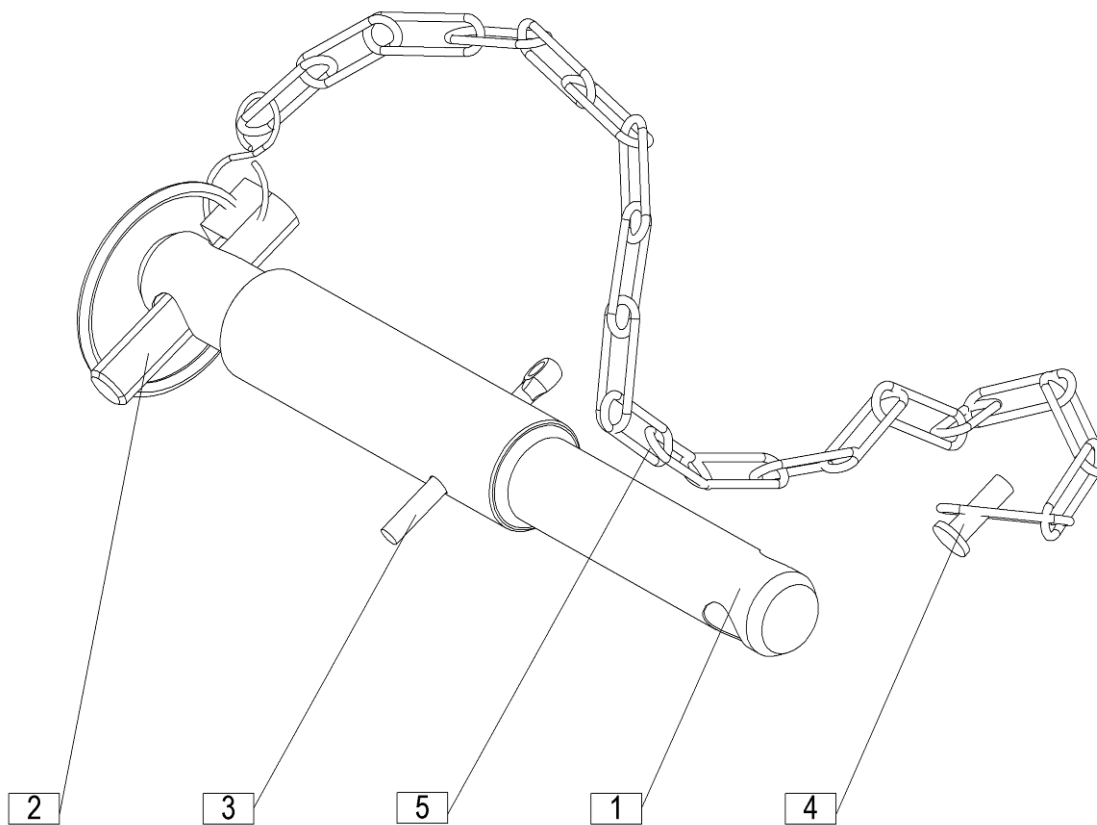





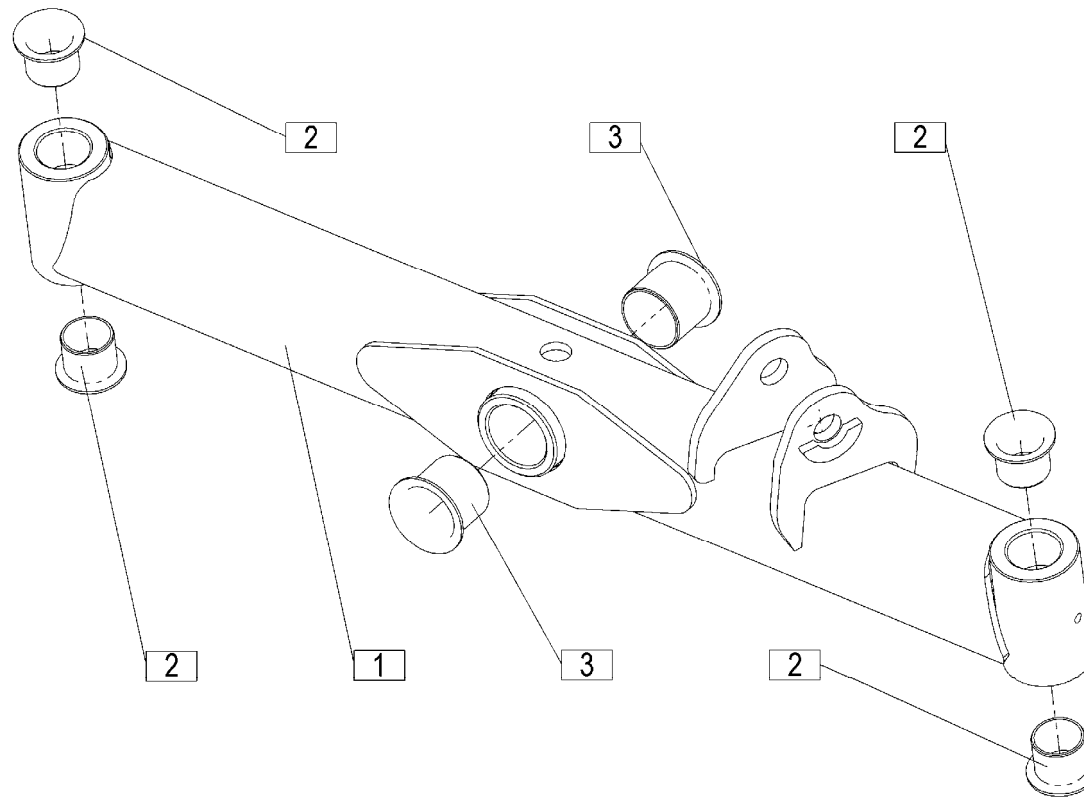



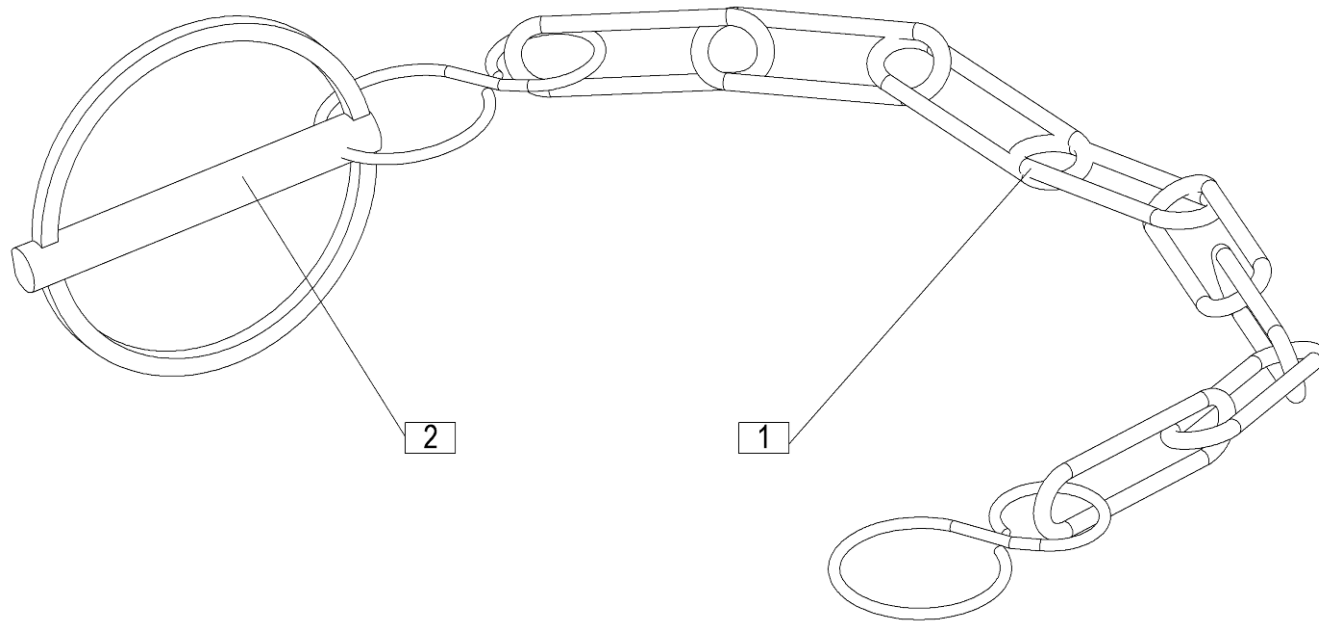



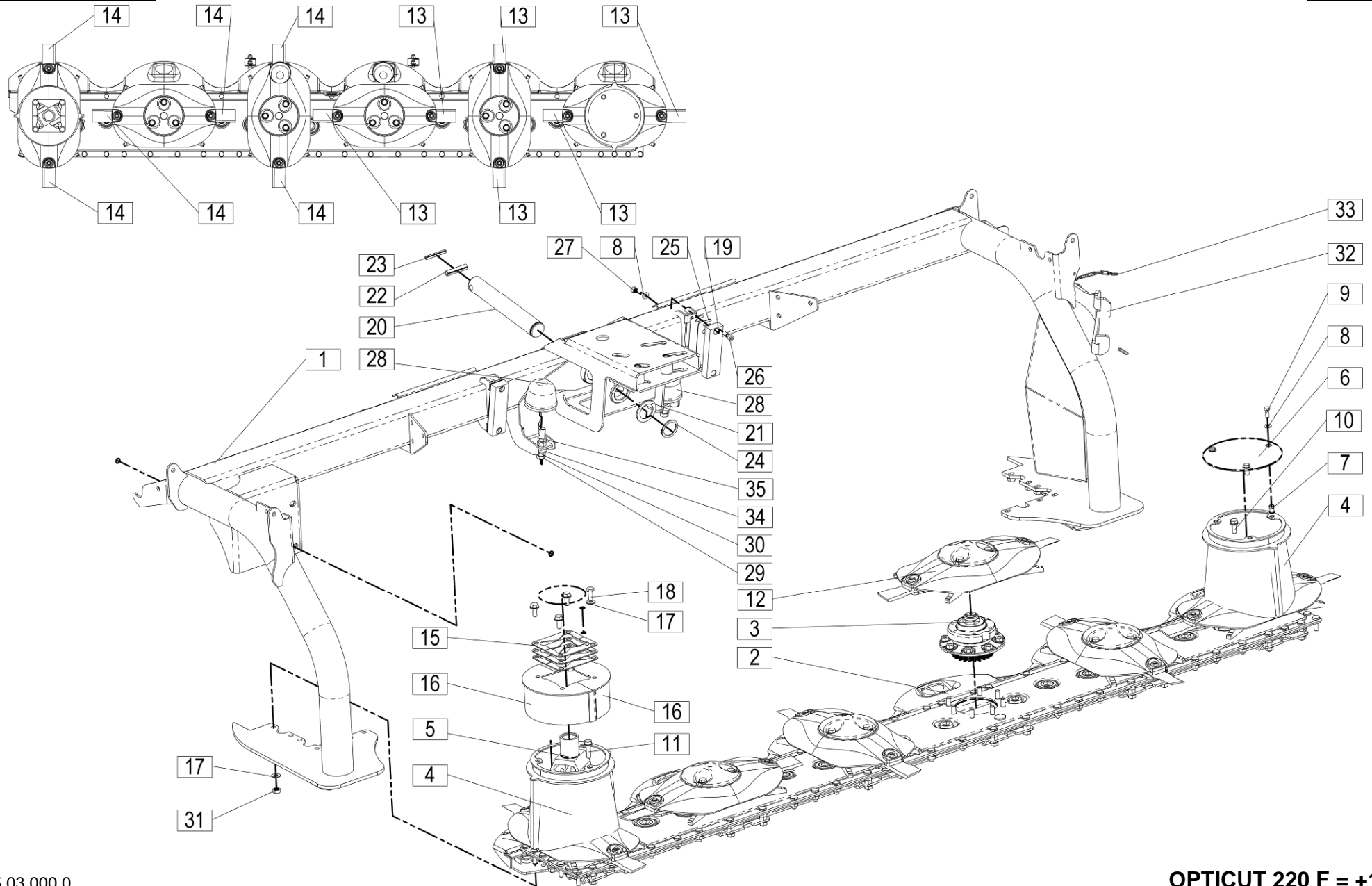



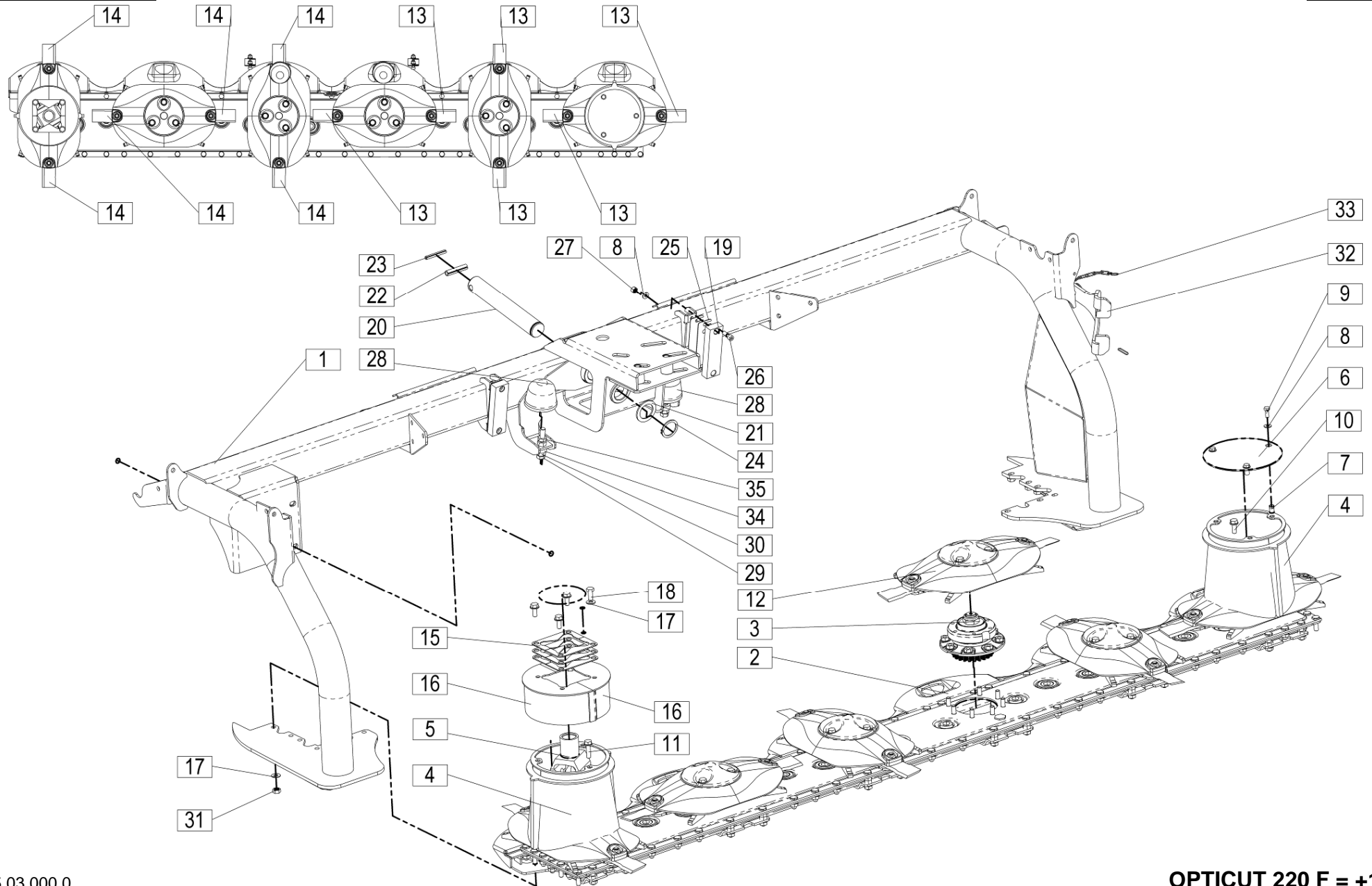





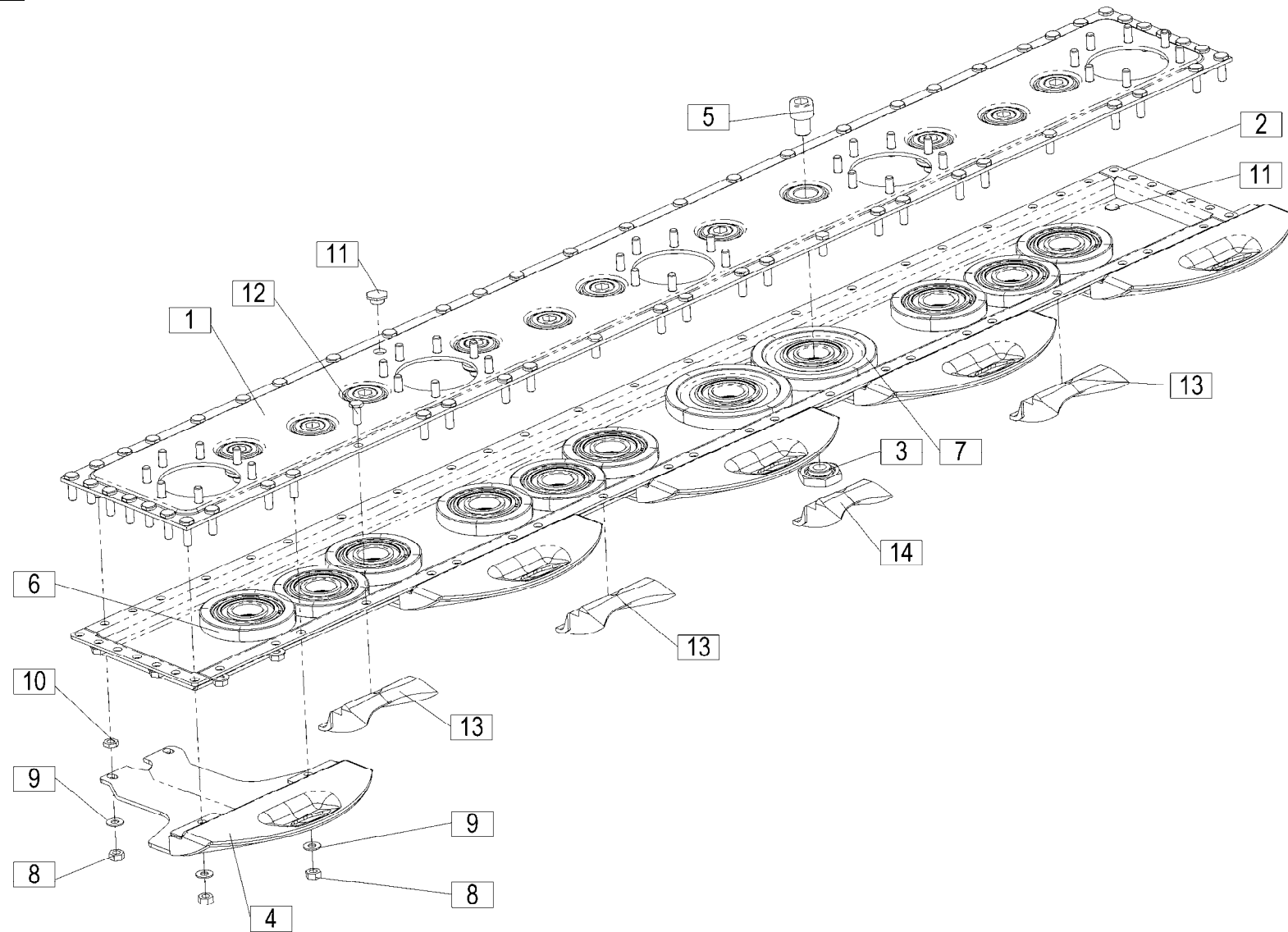



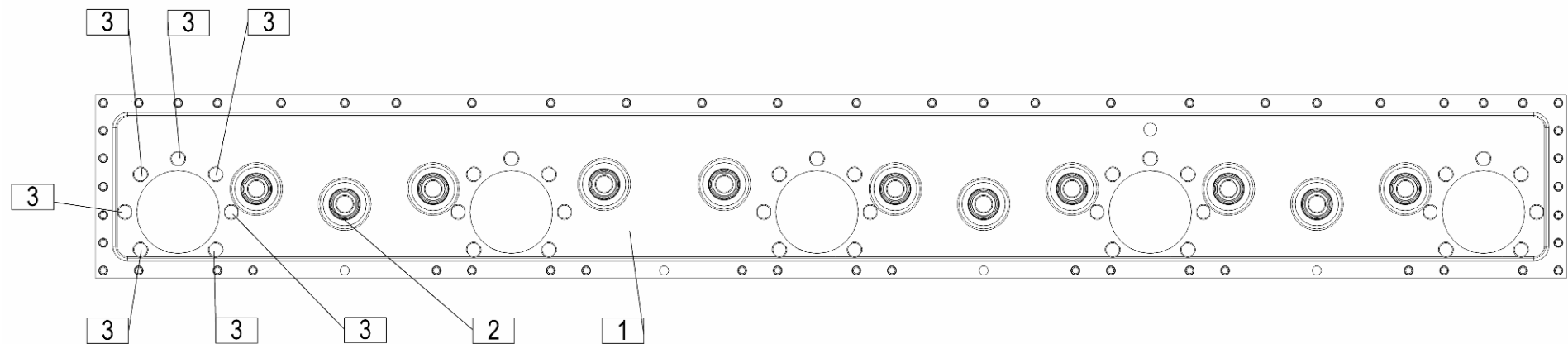
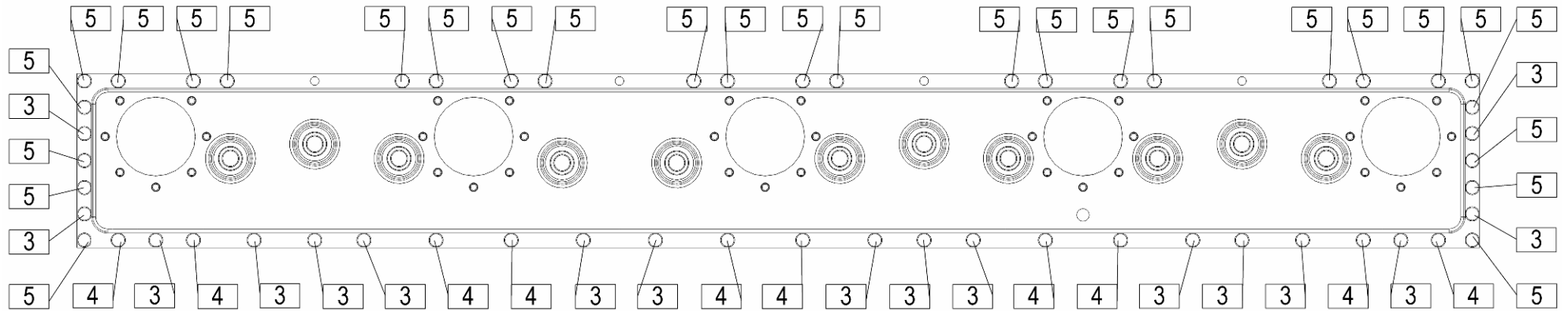



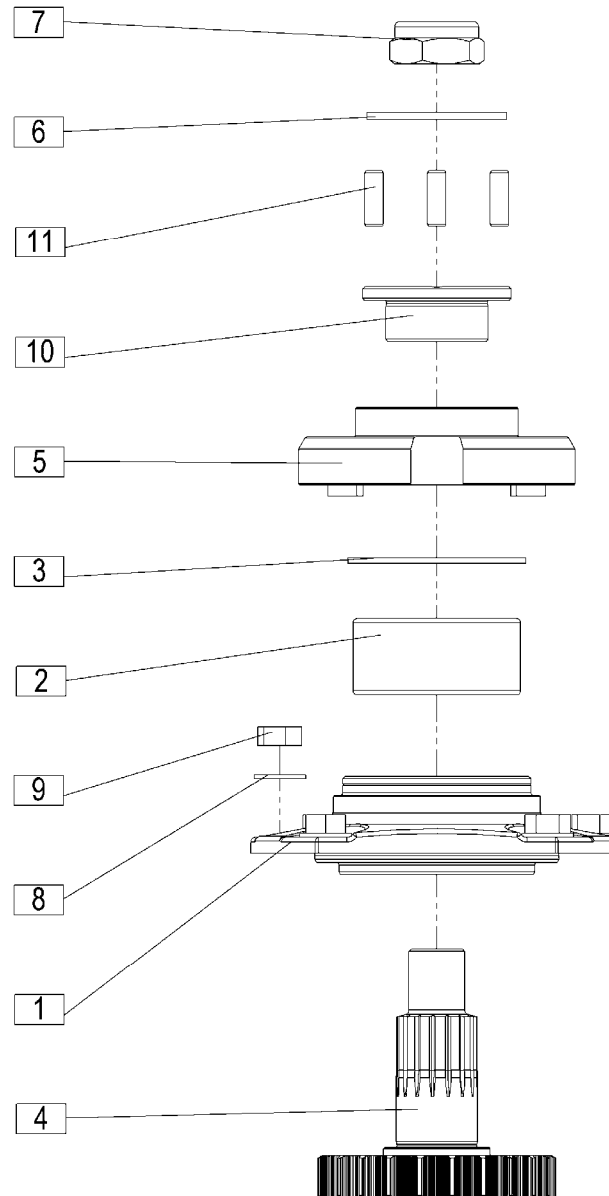



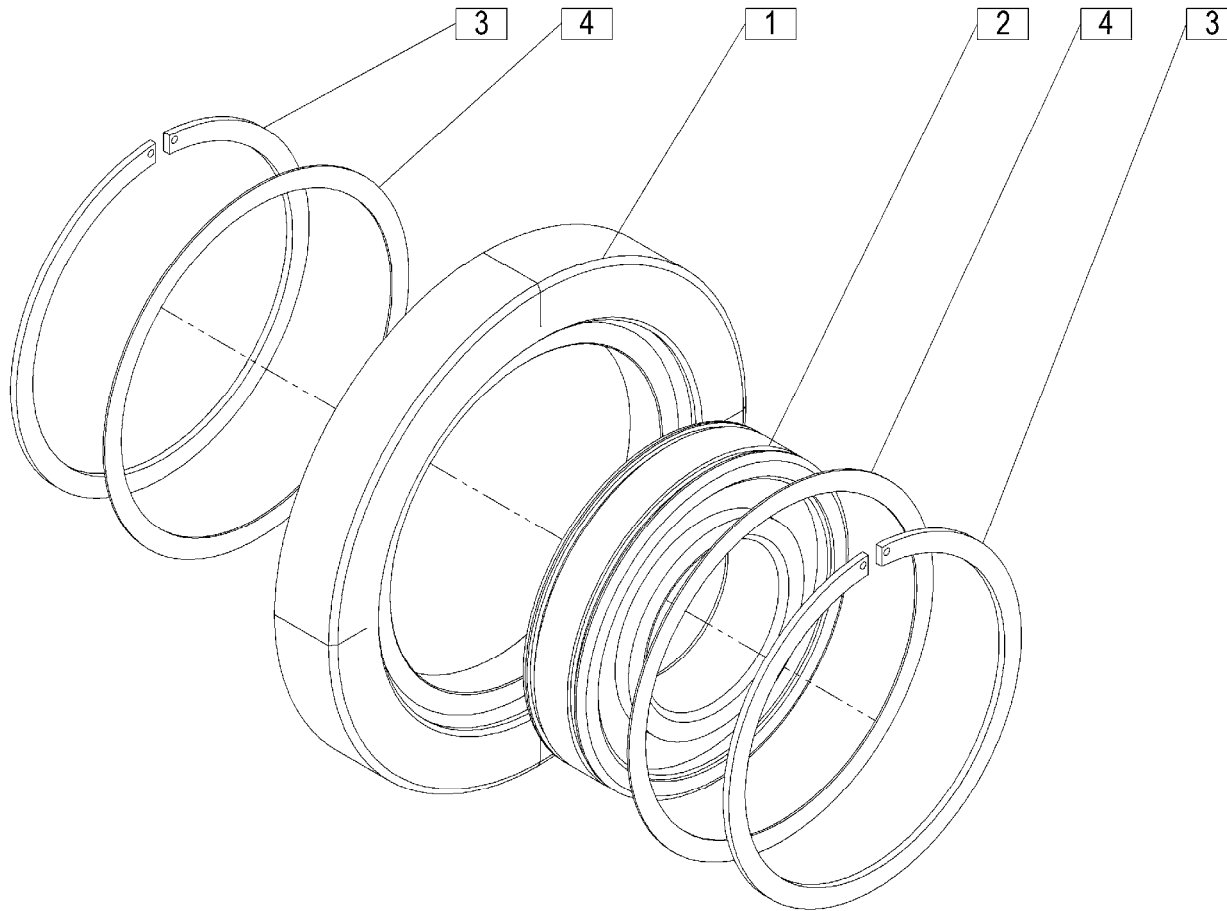





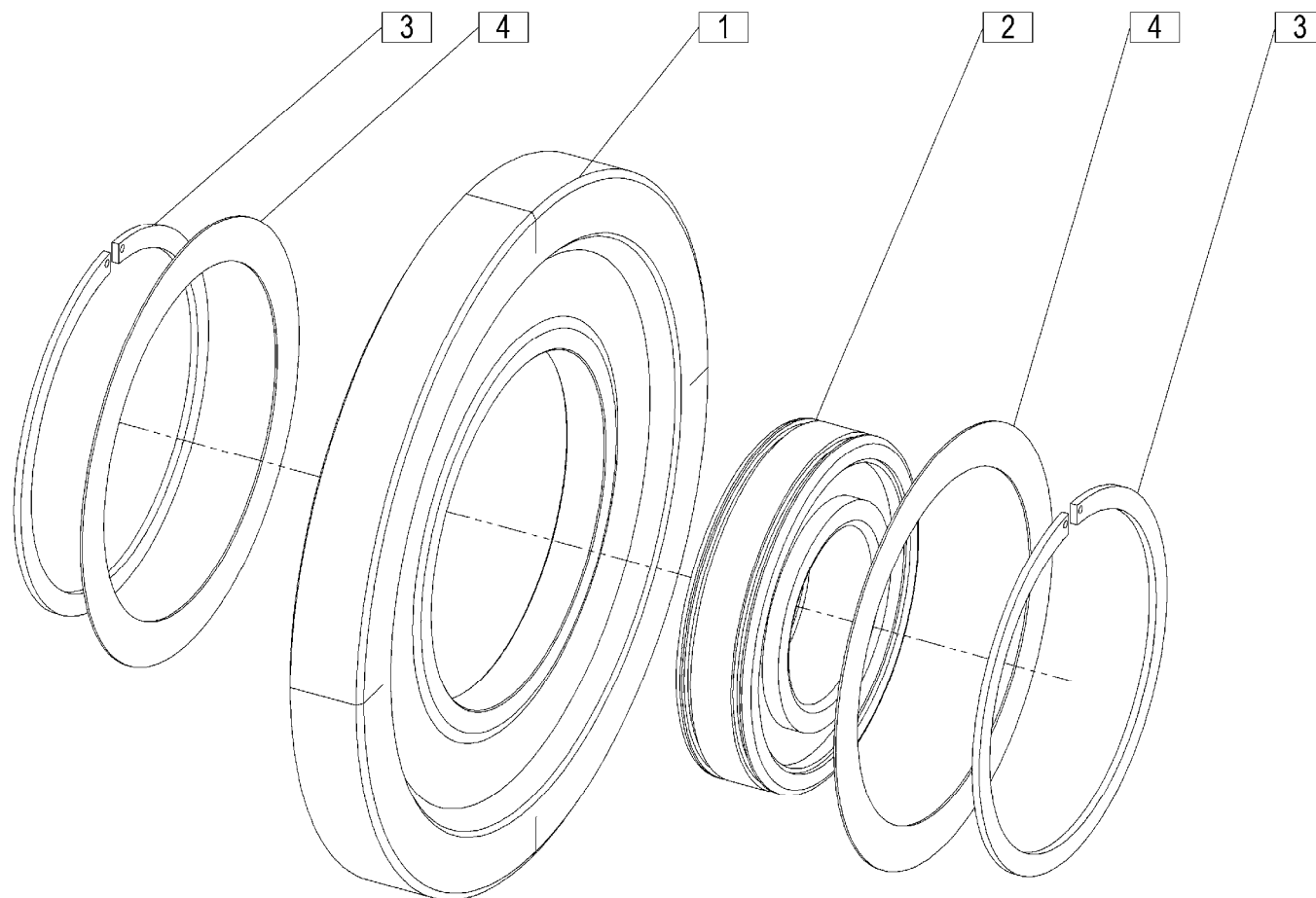



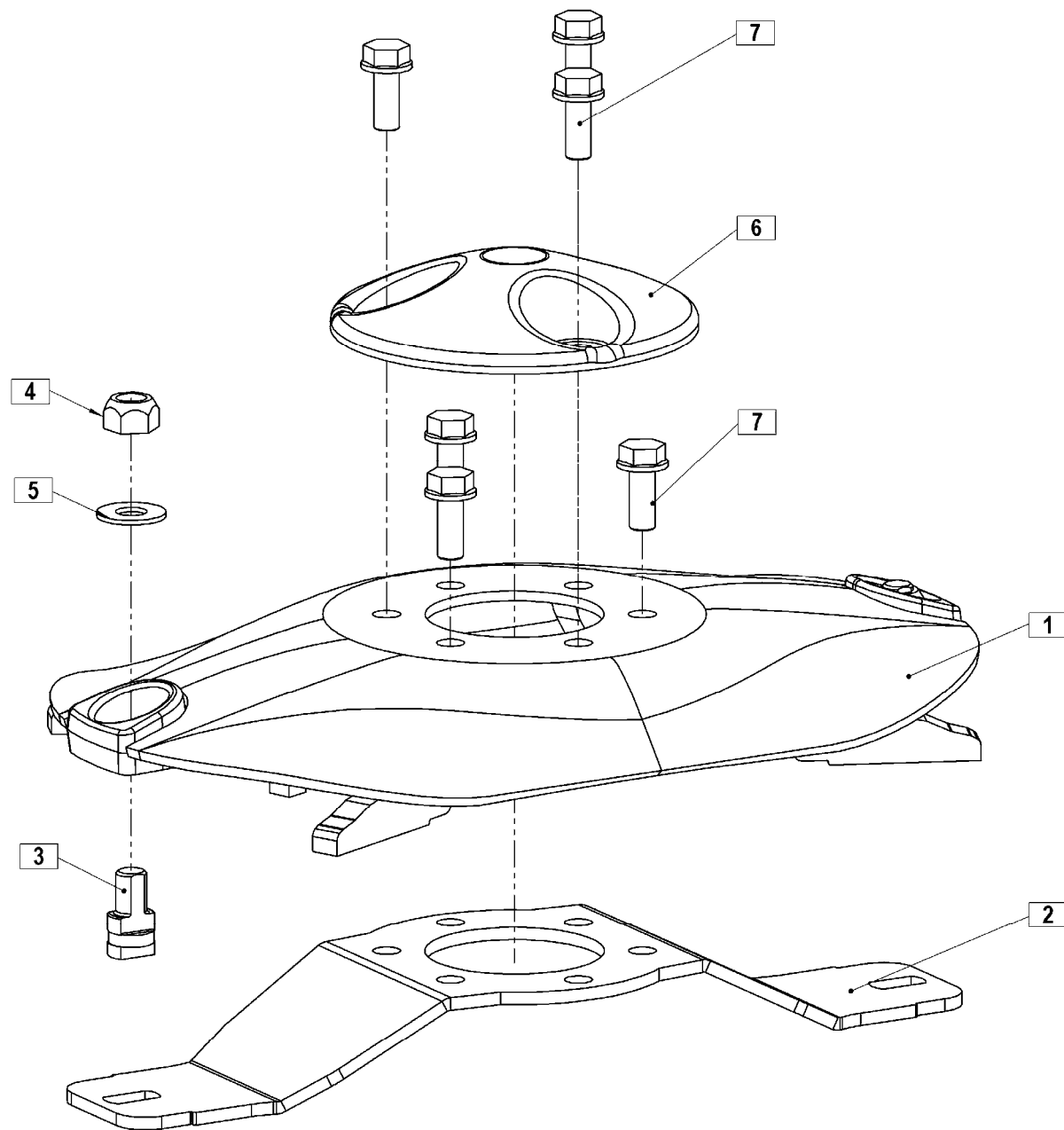



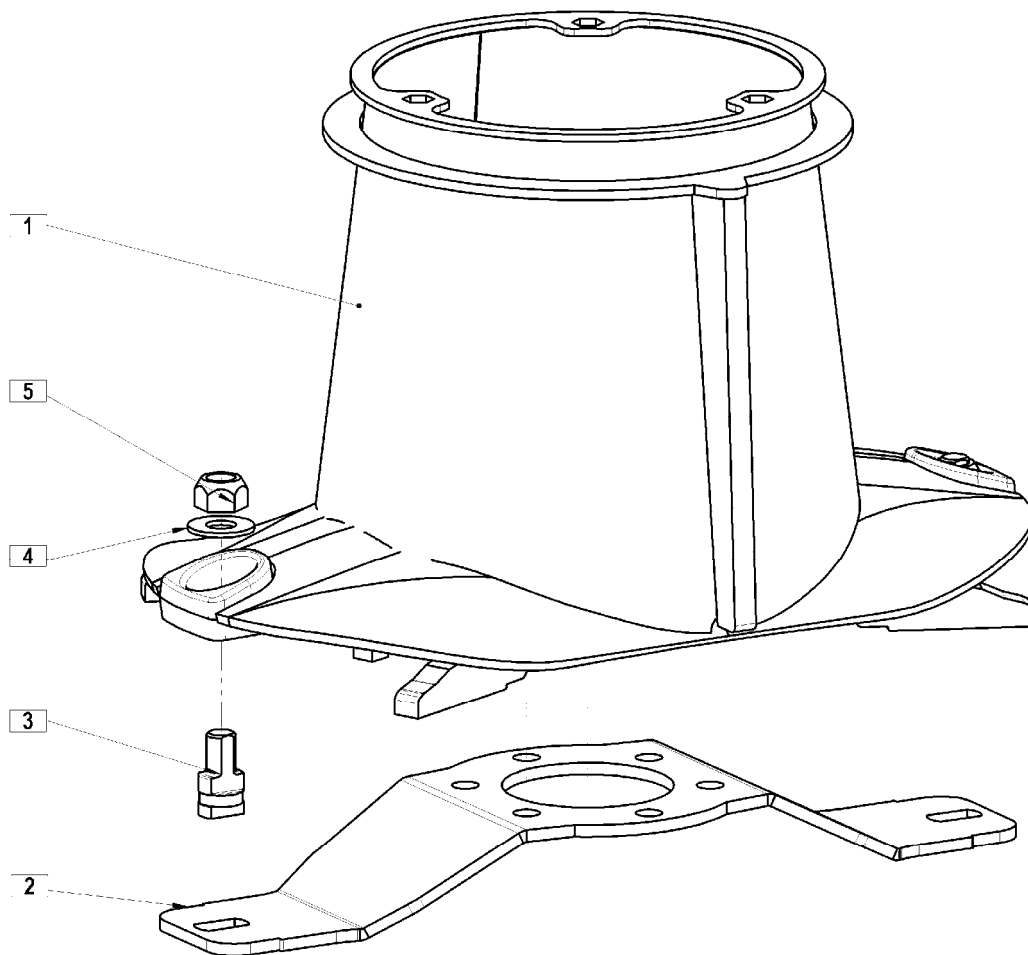



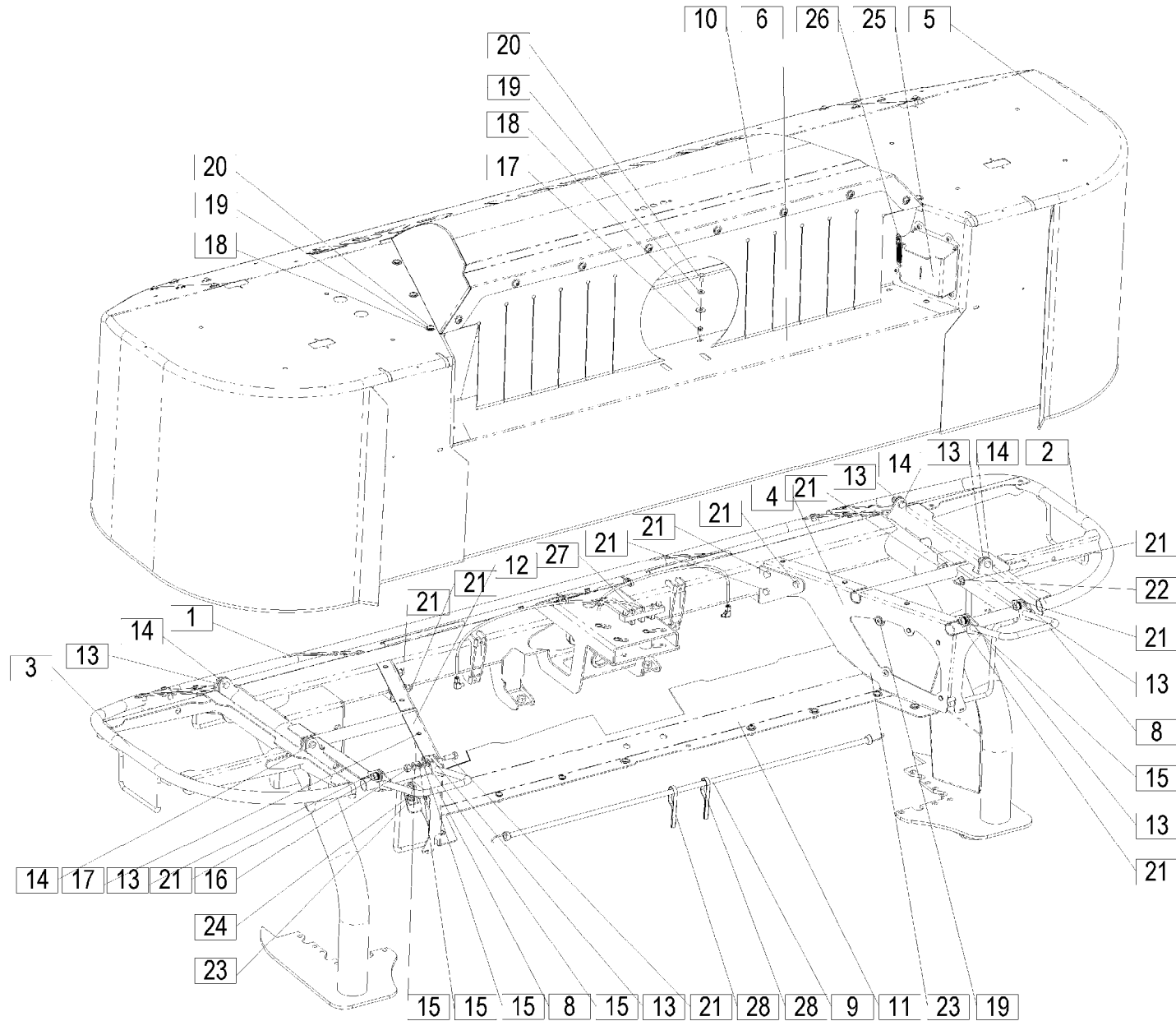





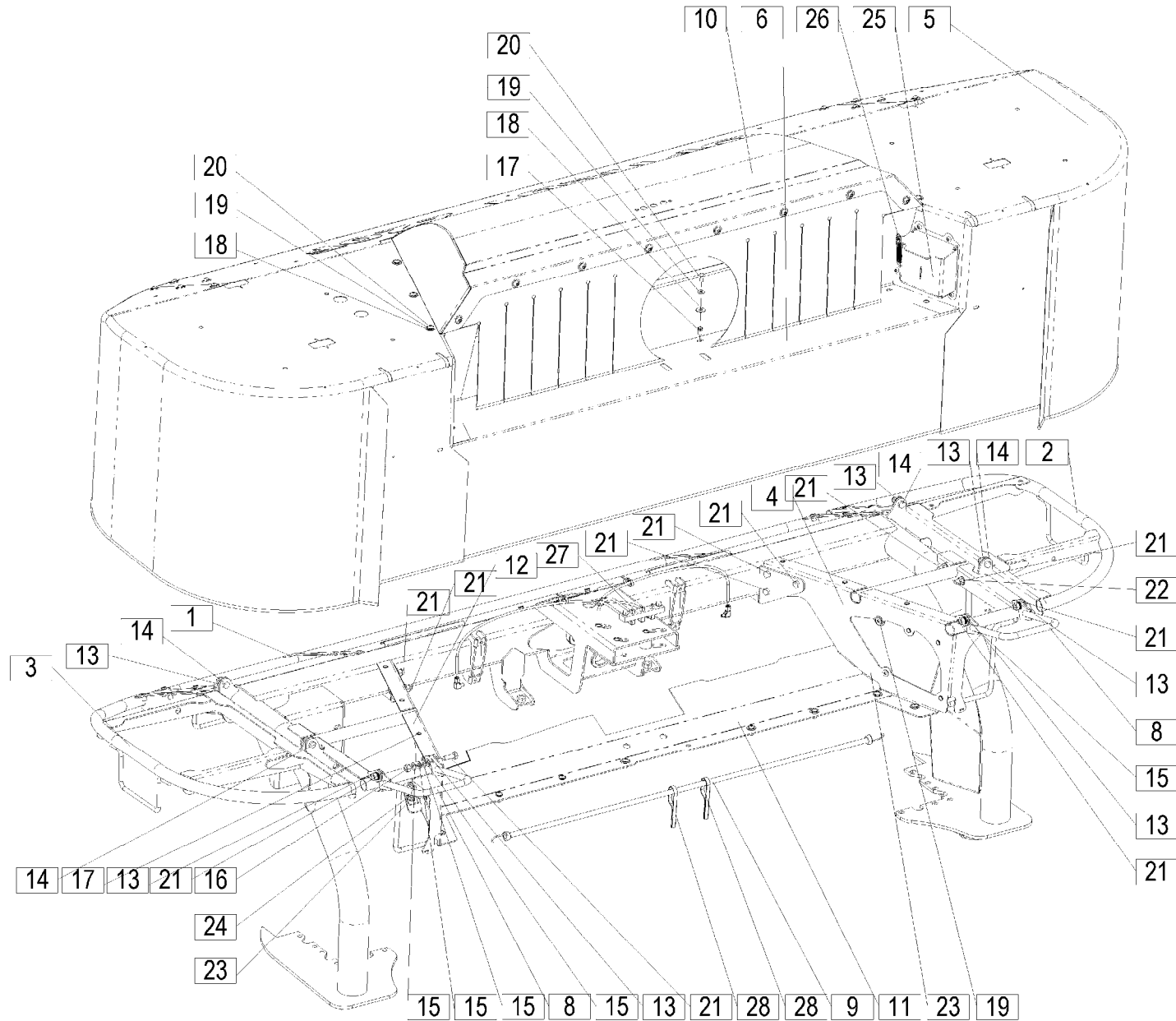



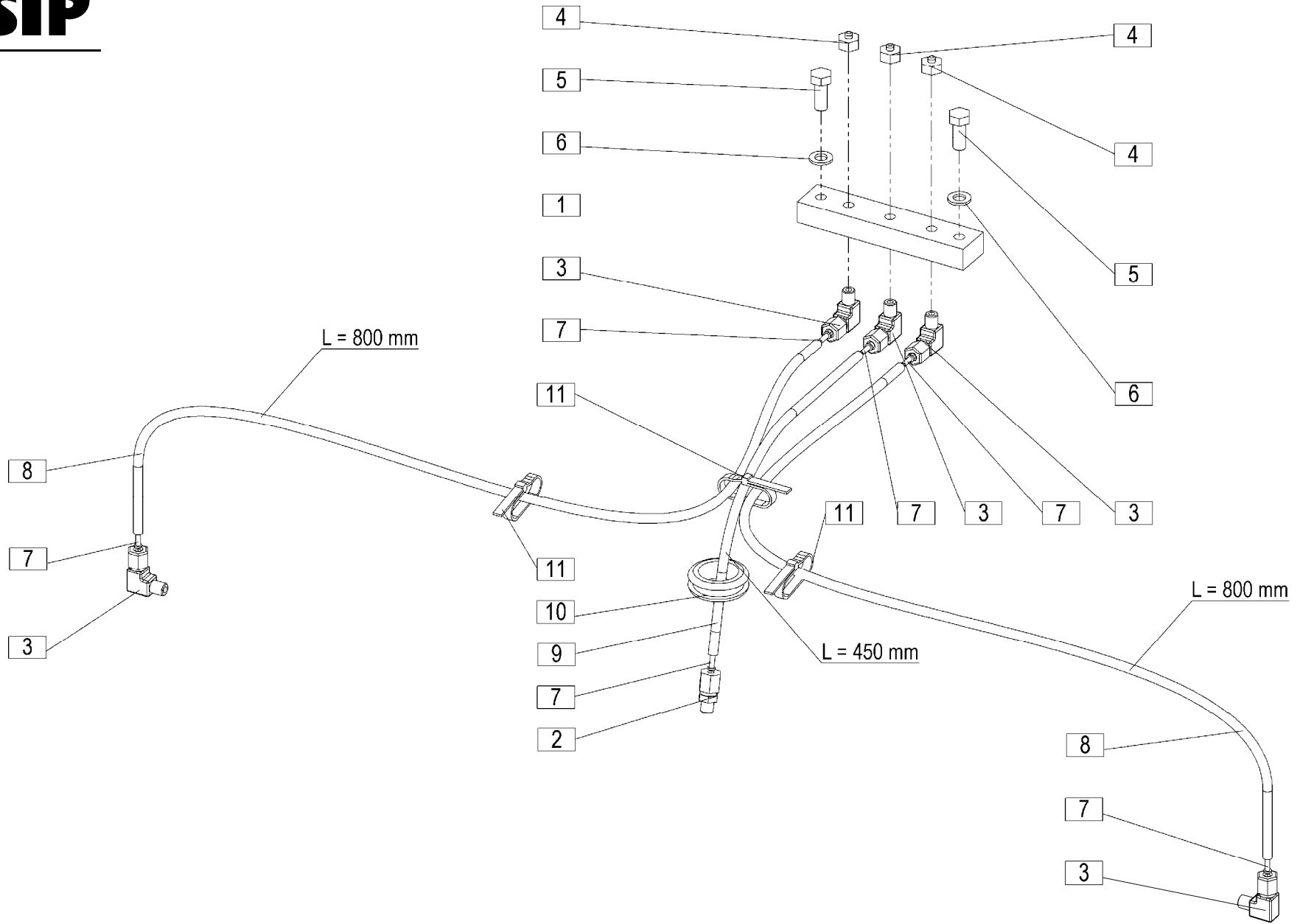



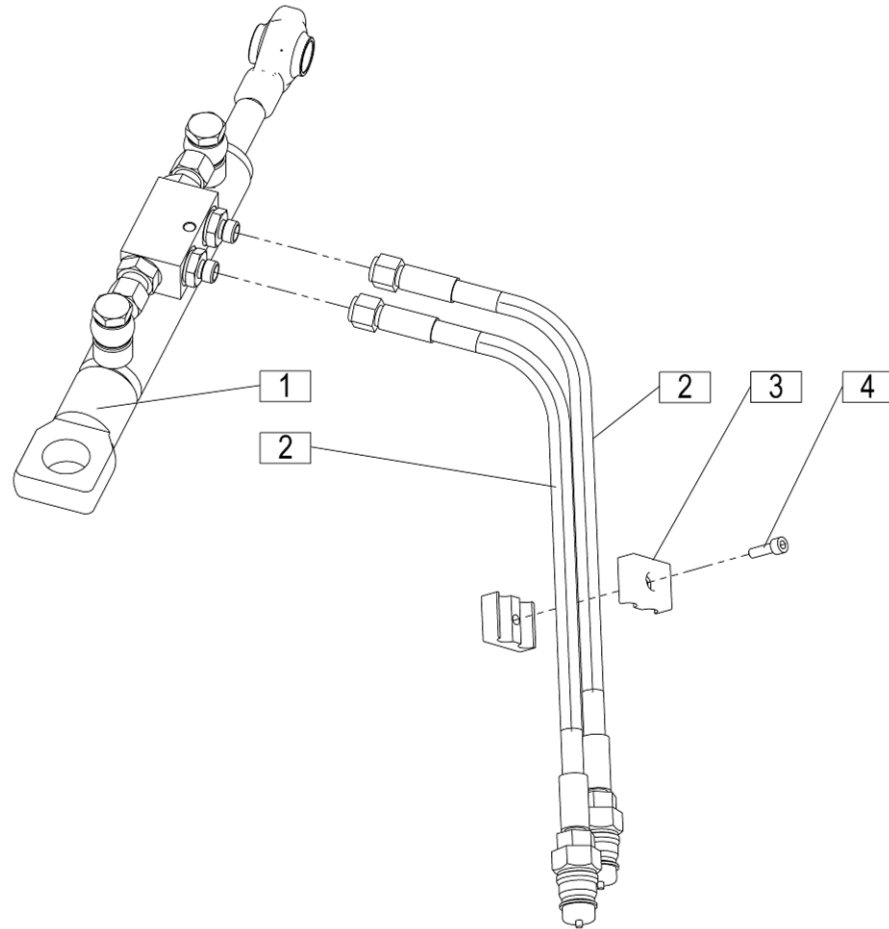



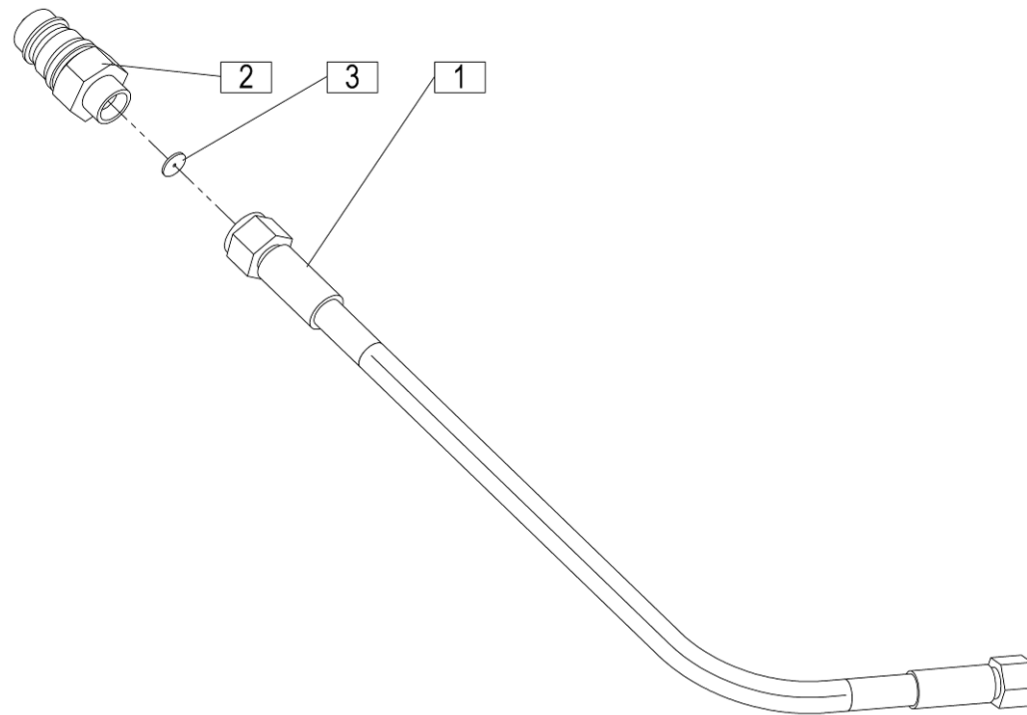





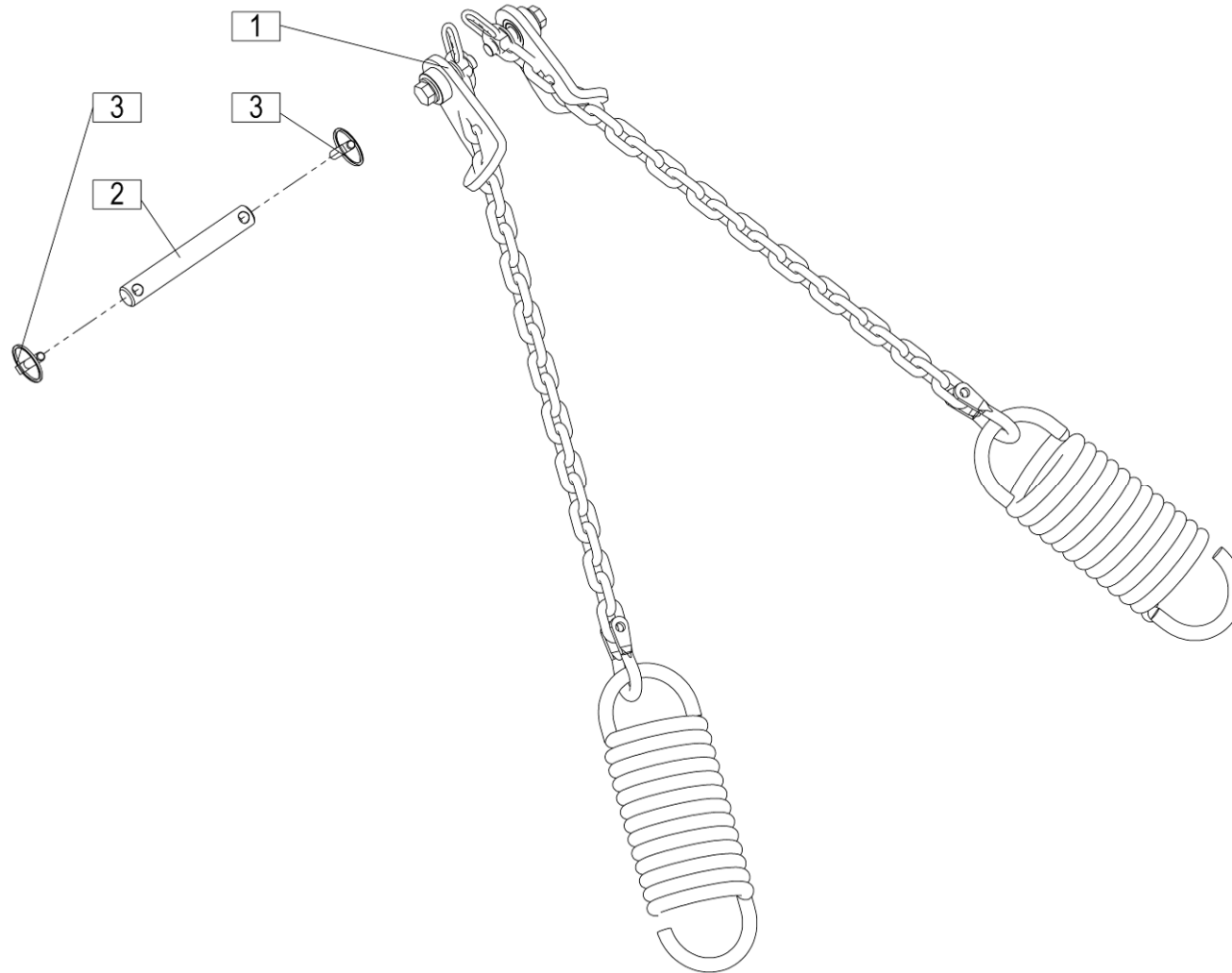



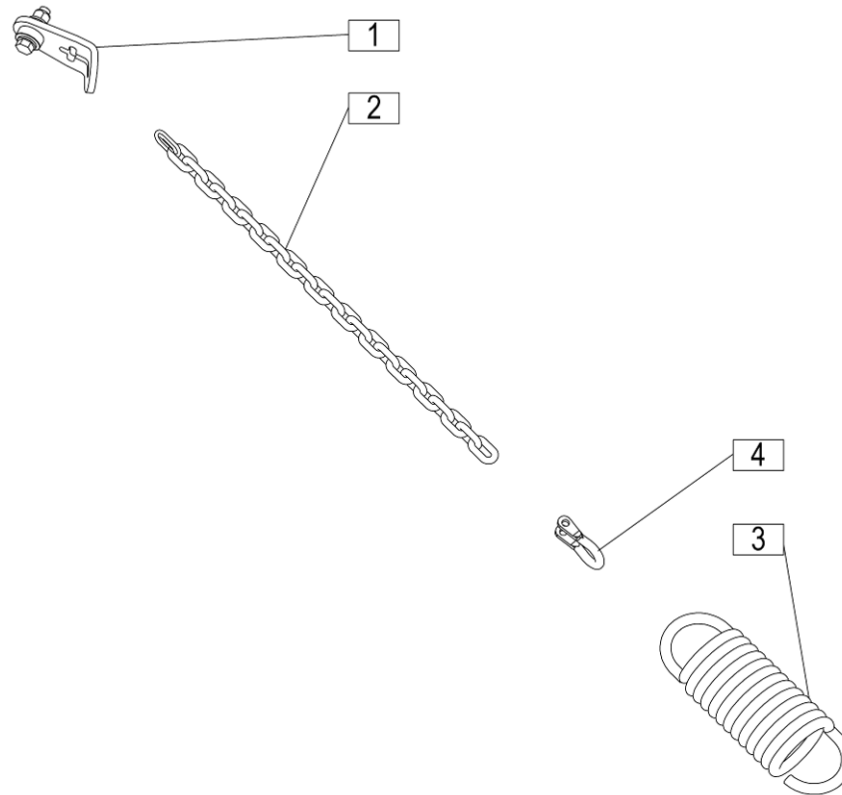



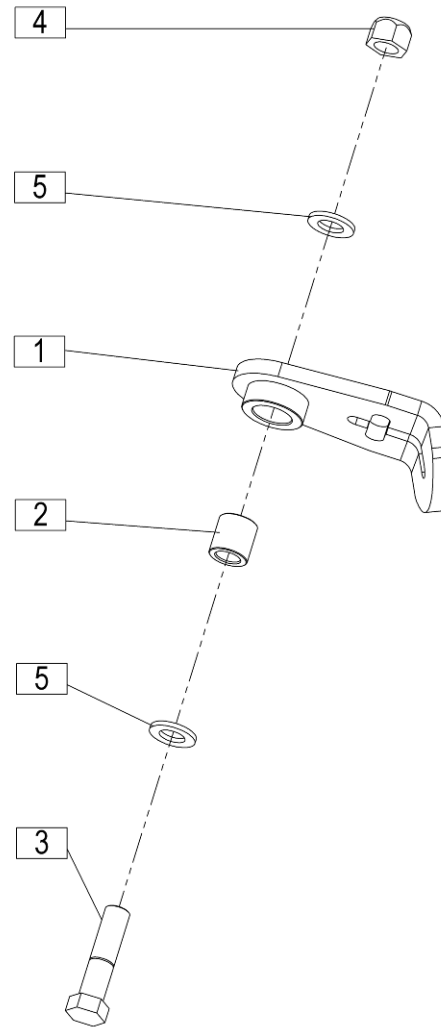



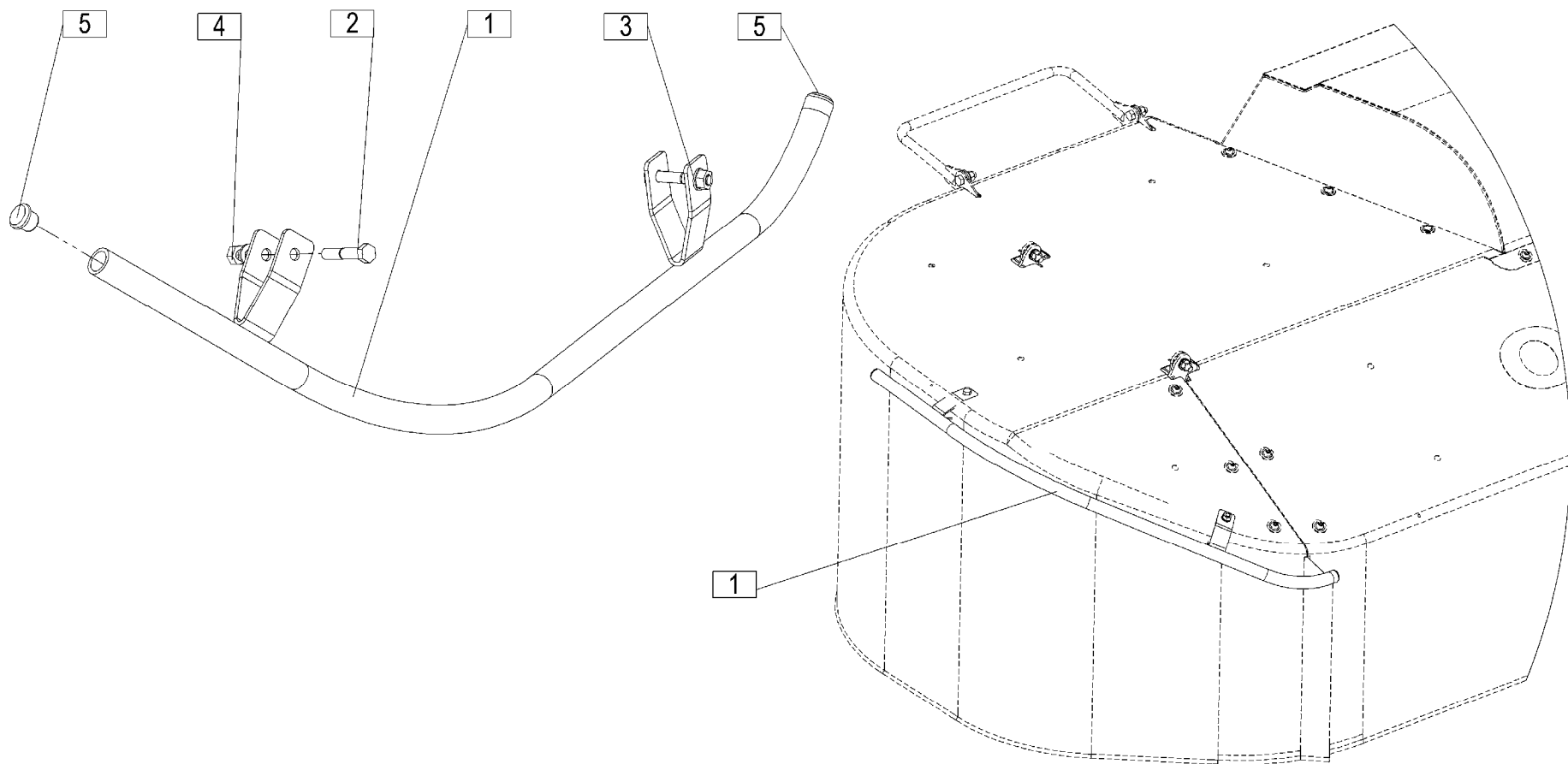





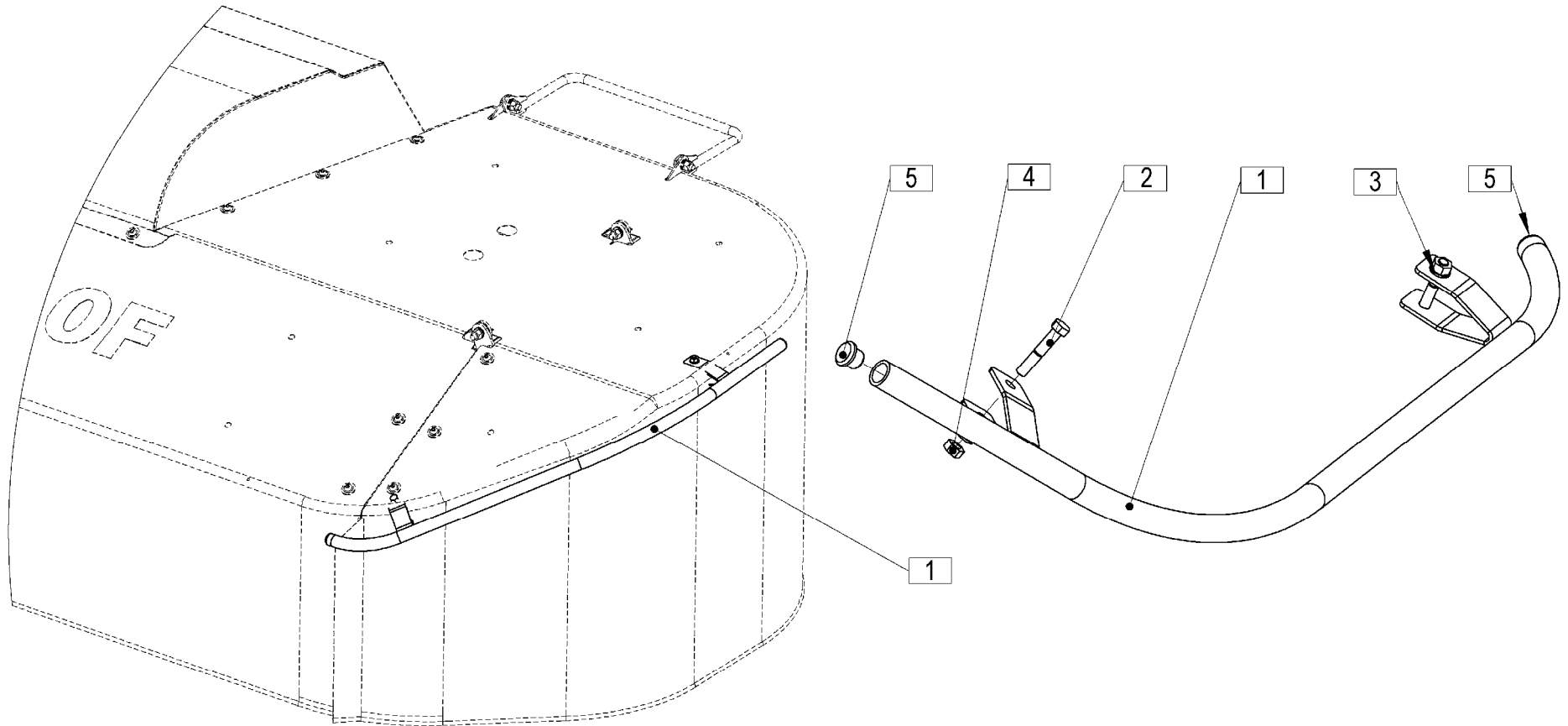



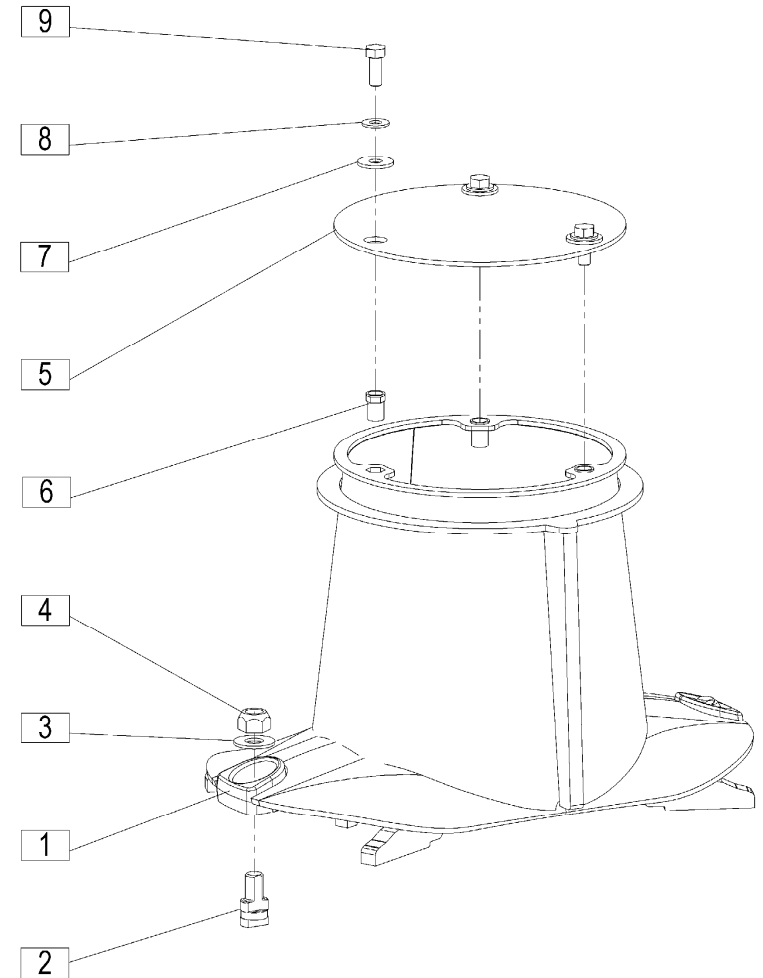
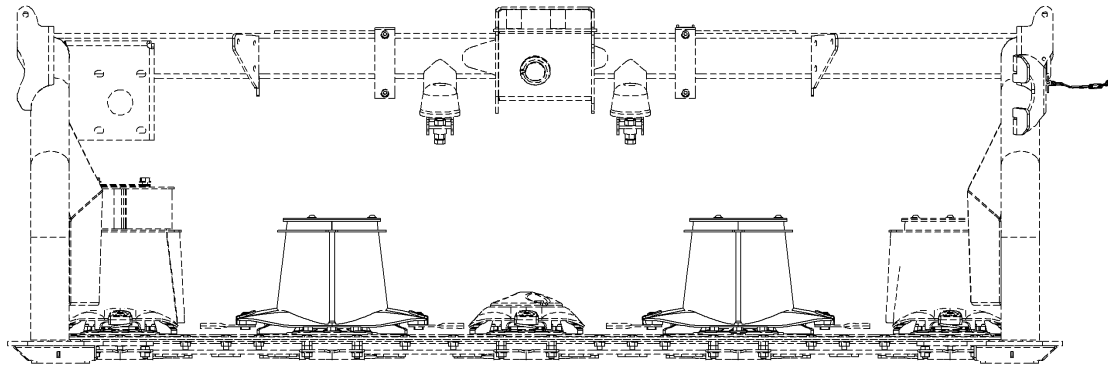



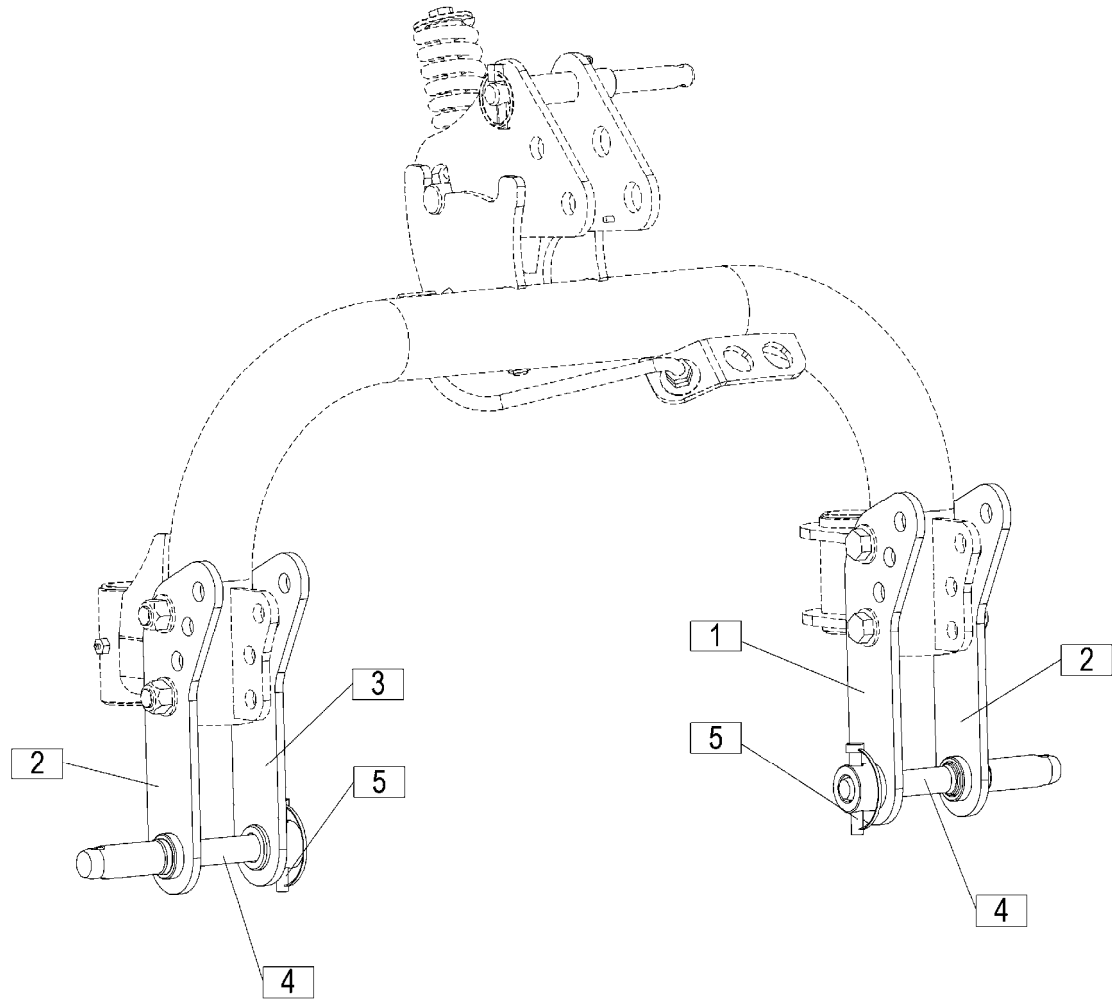



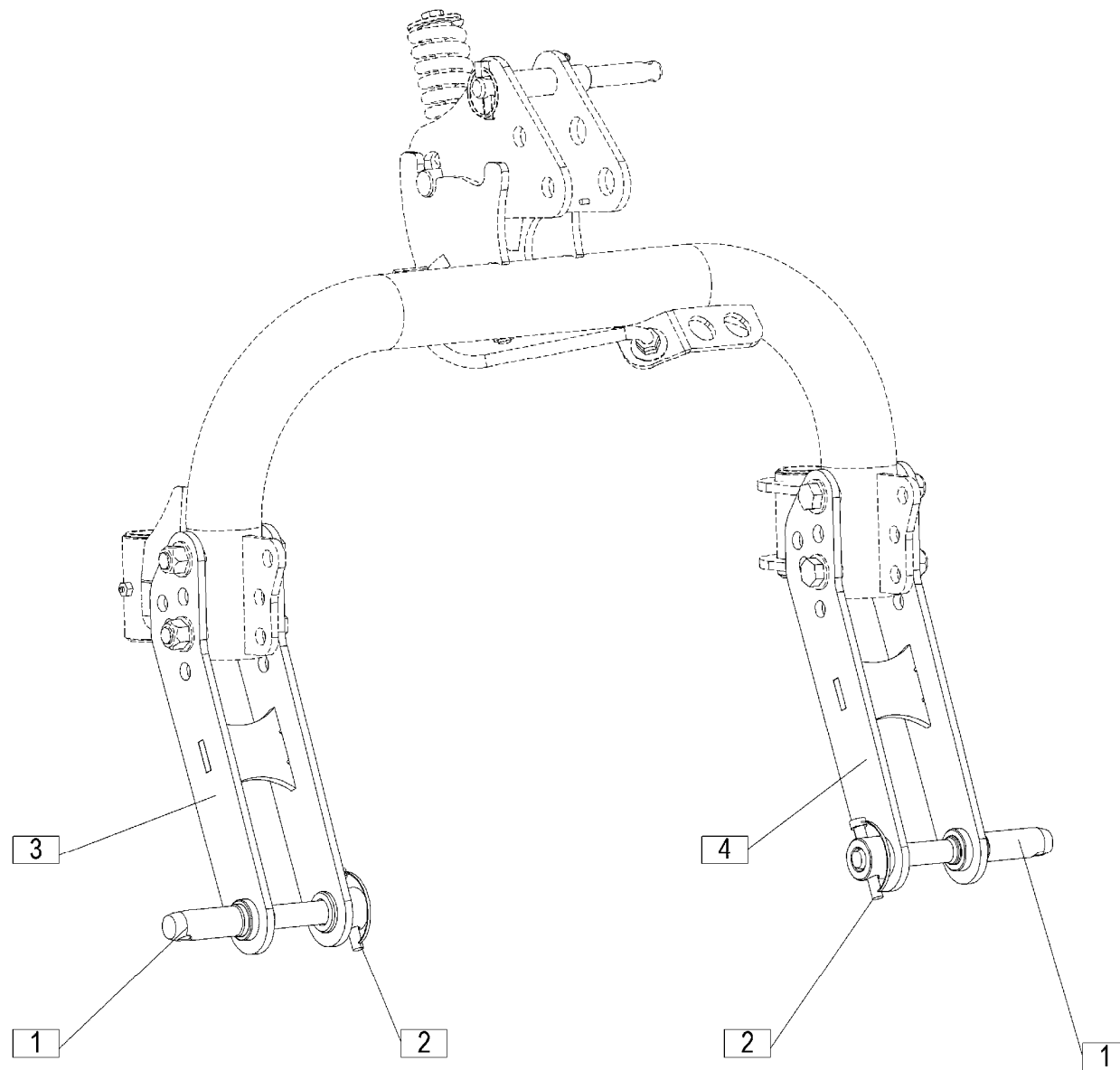





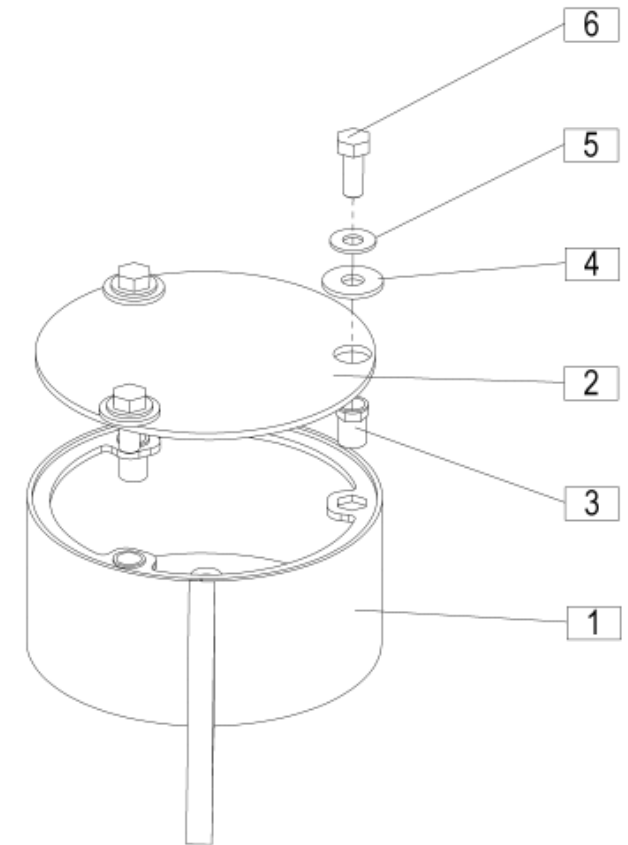
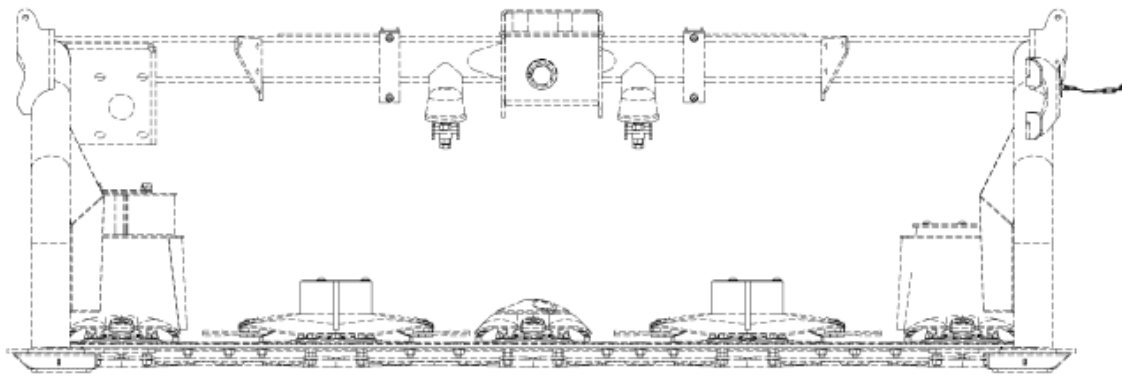



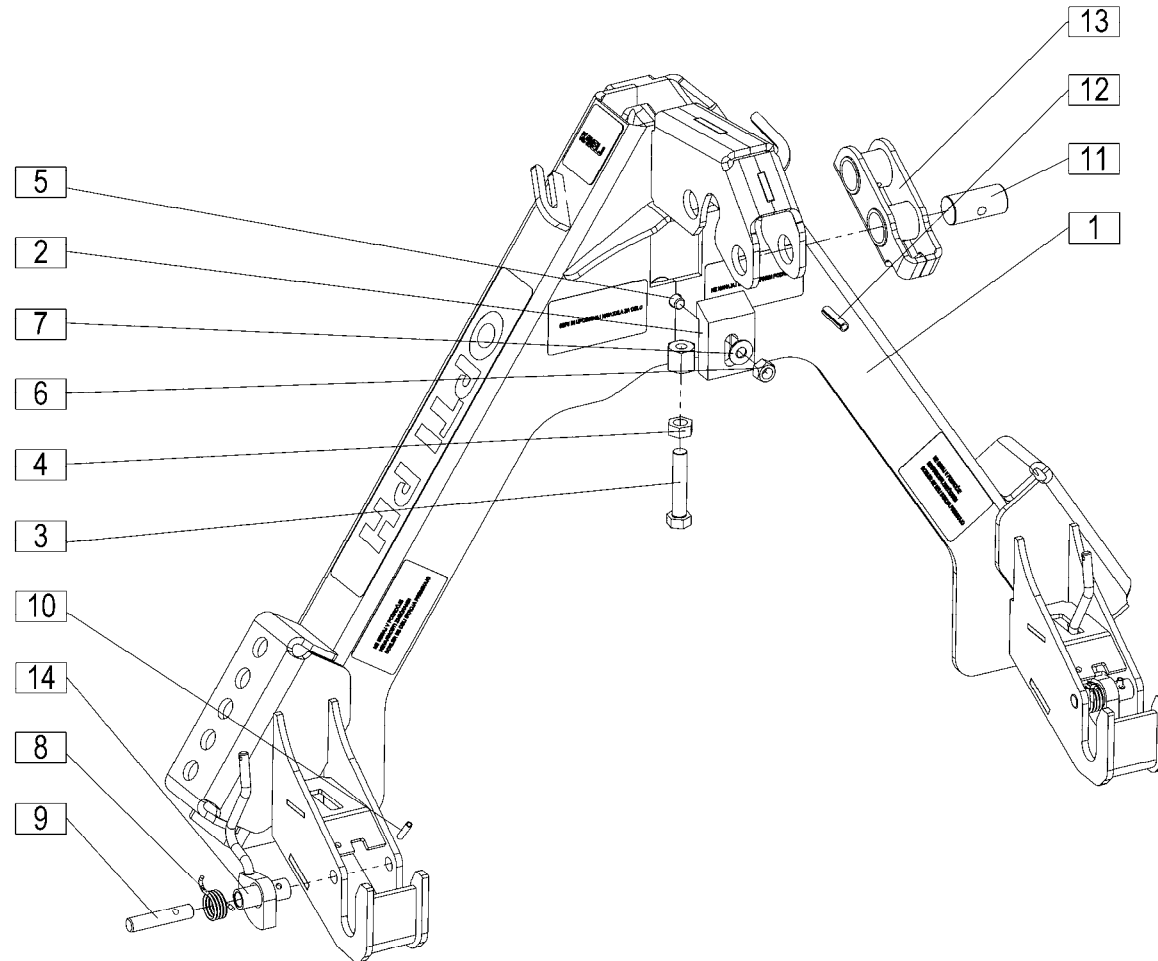



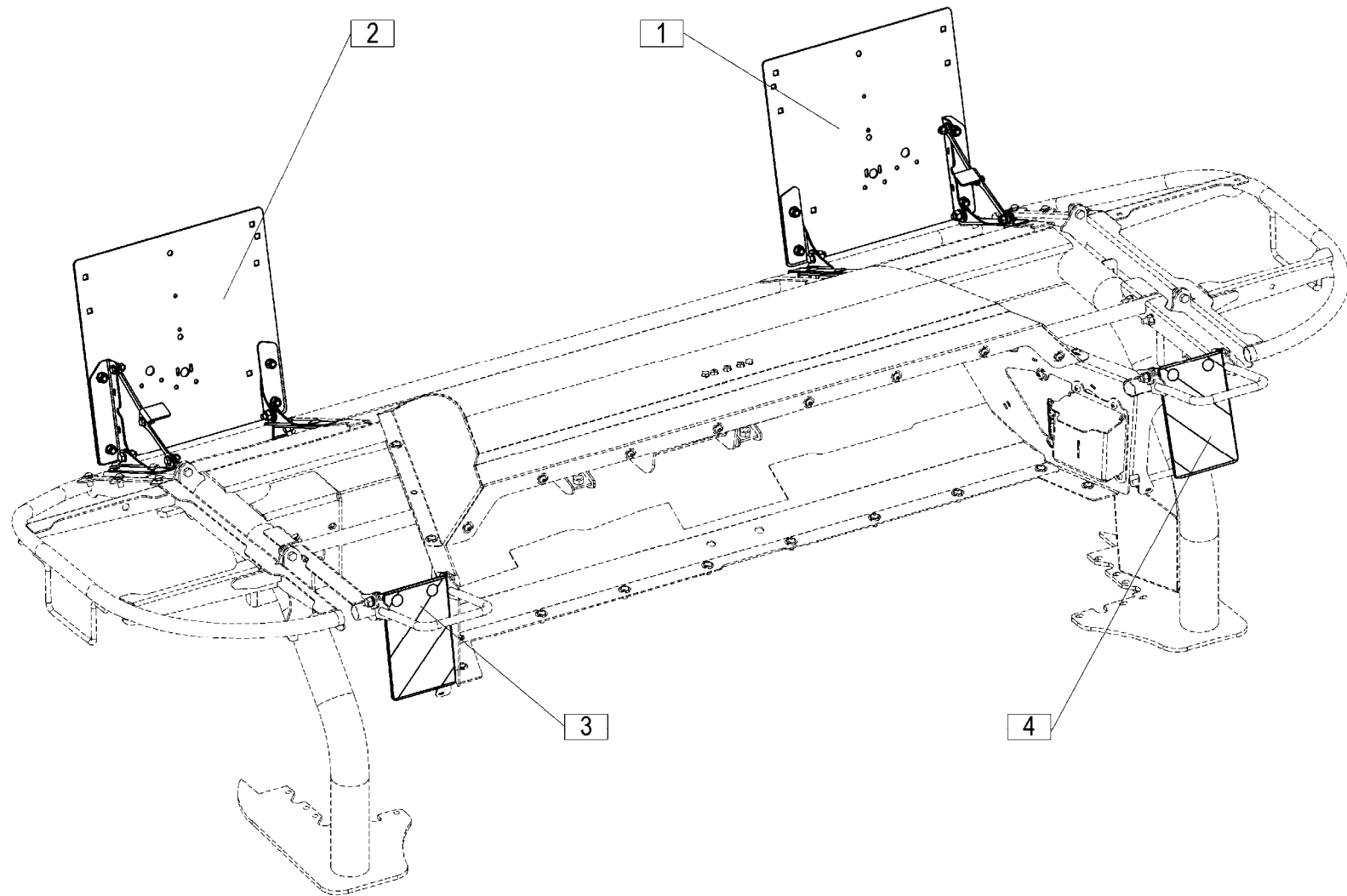



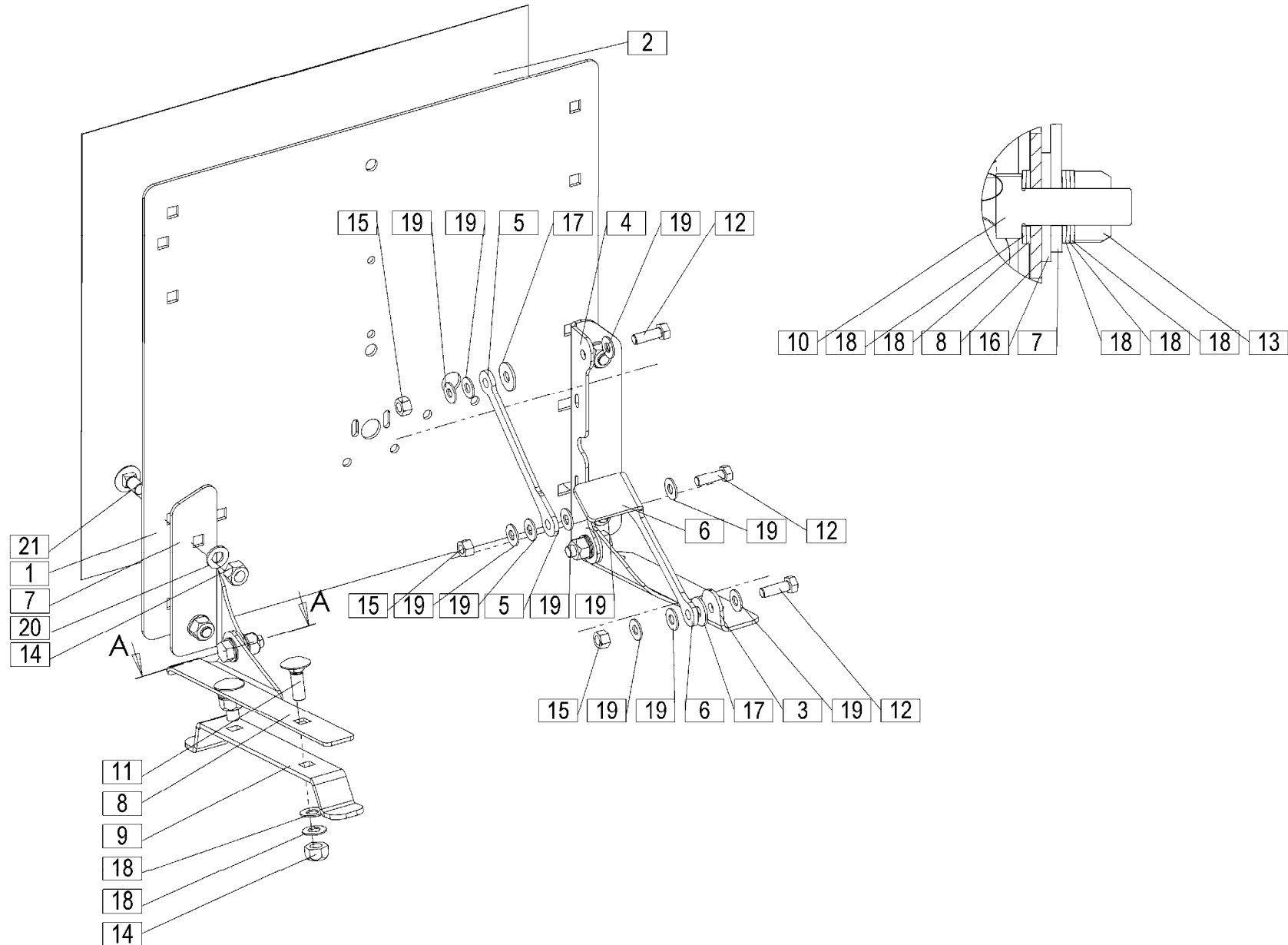





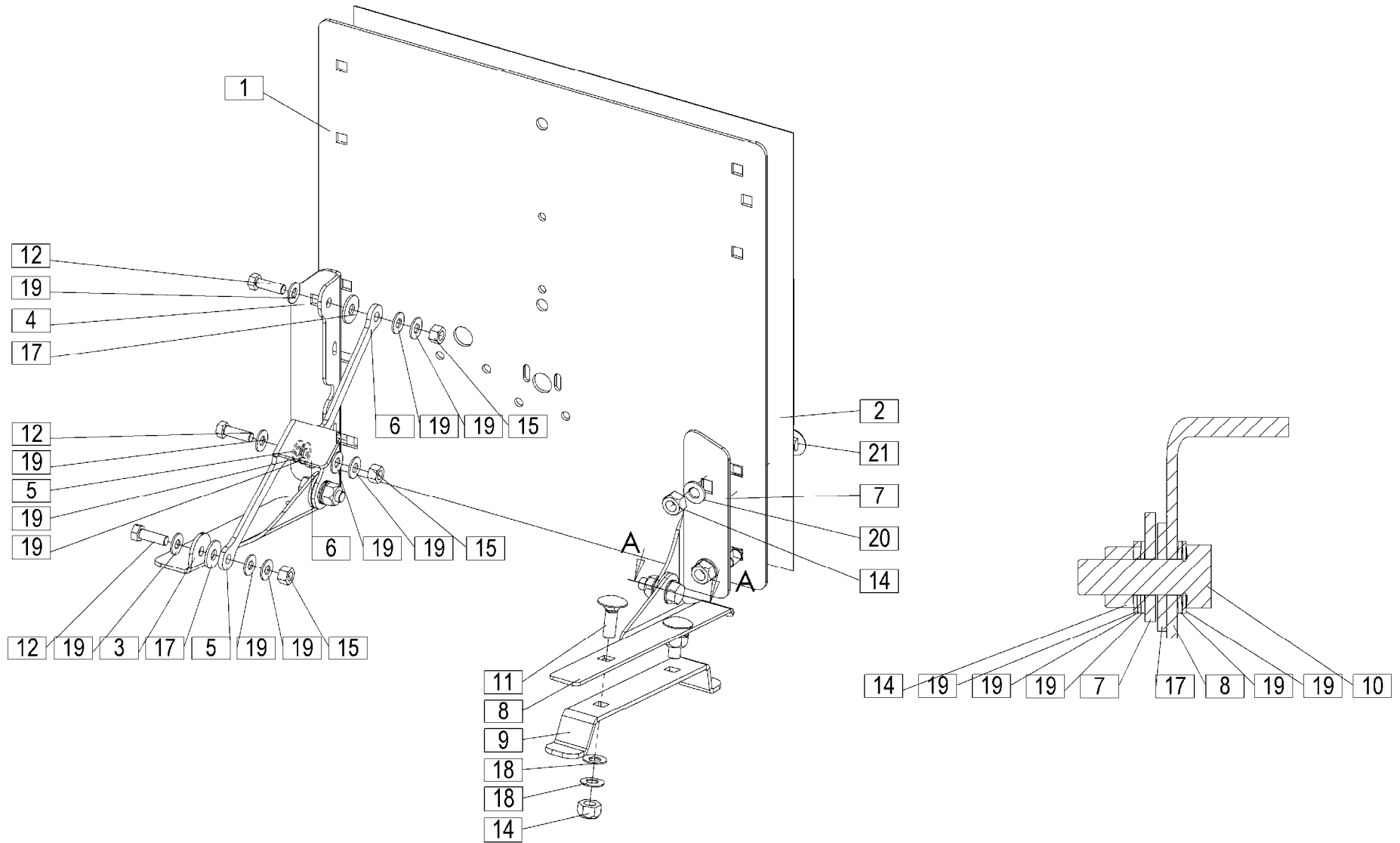



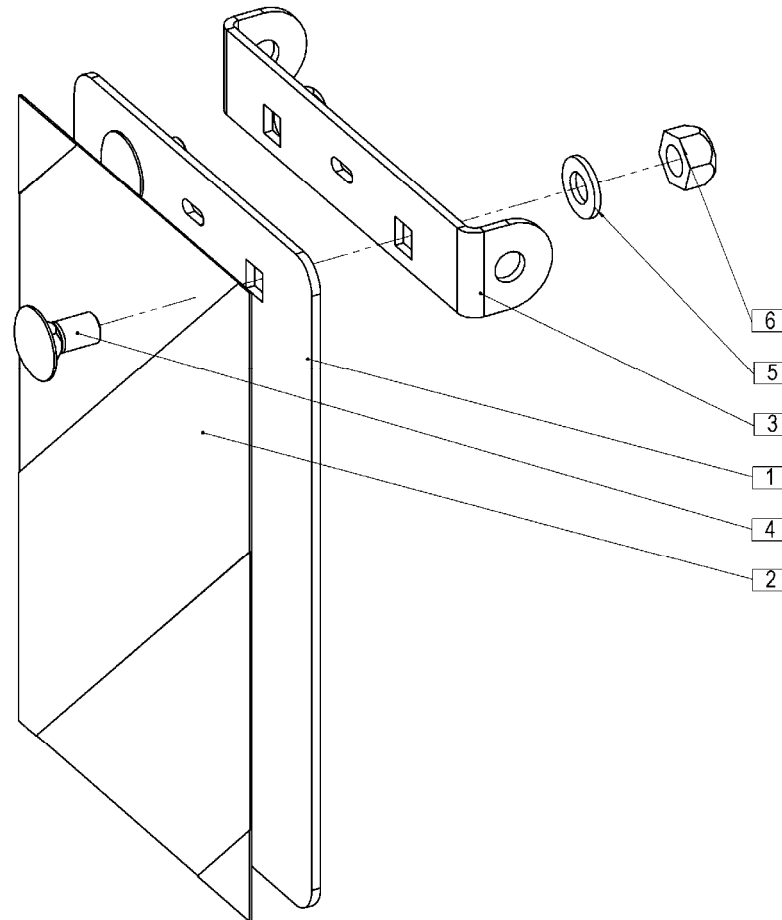



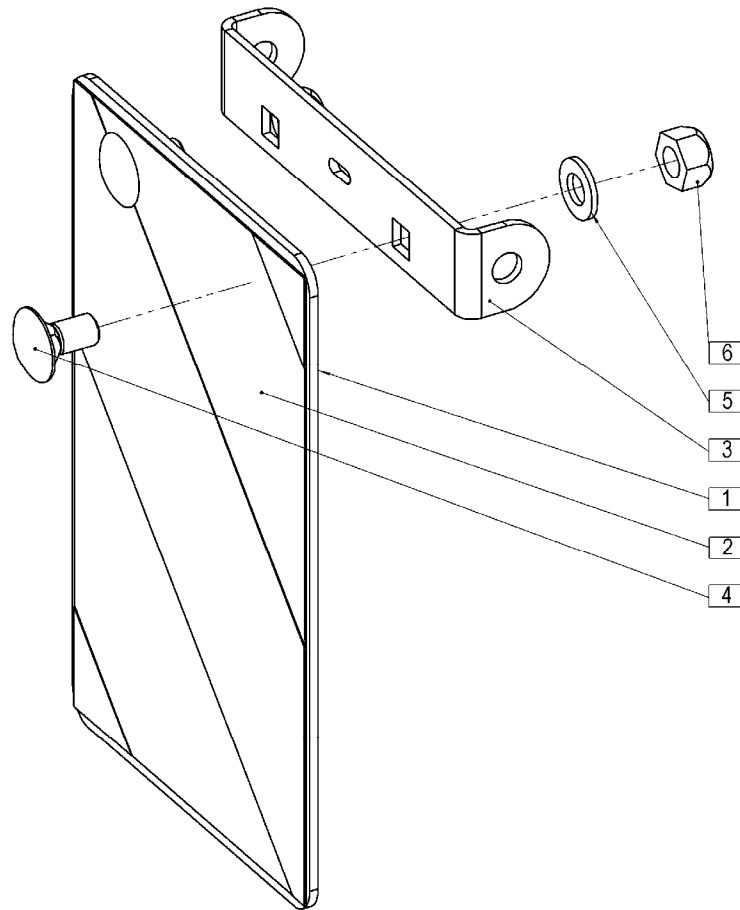



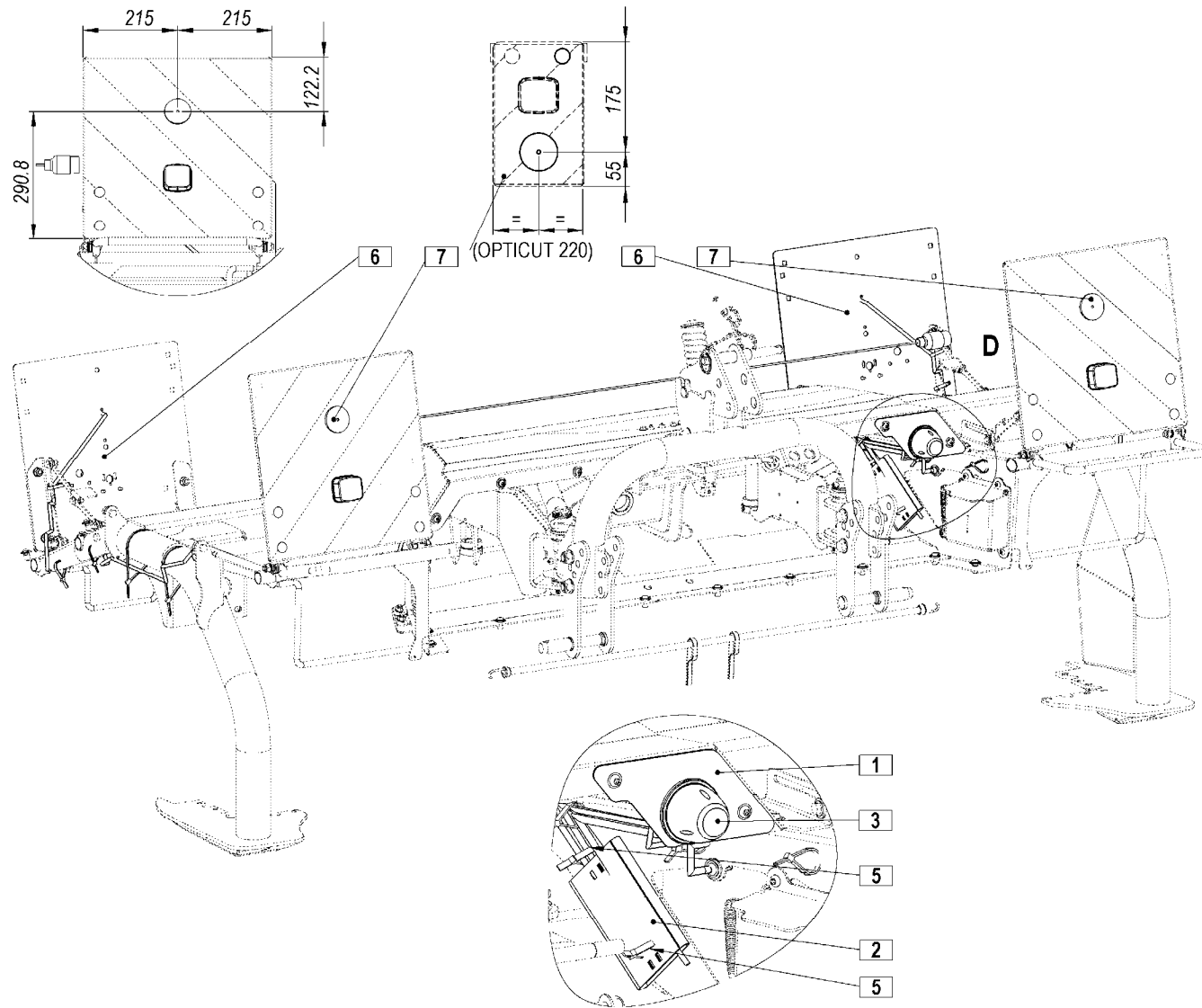





Prüfarmt Nr.: 60 931

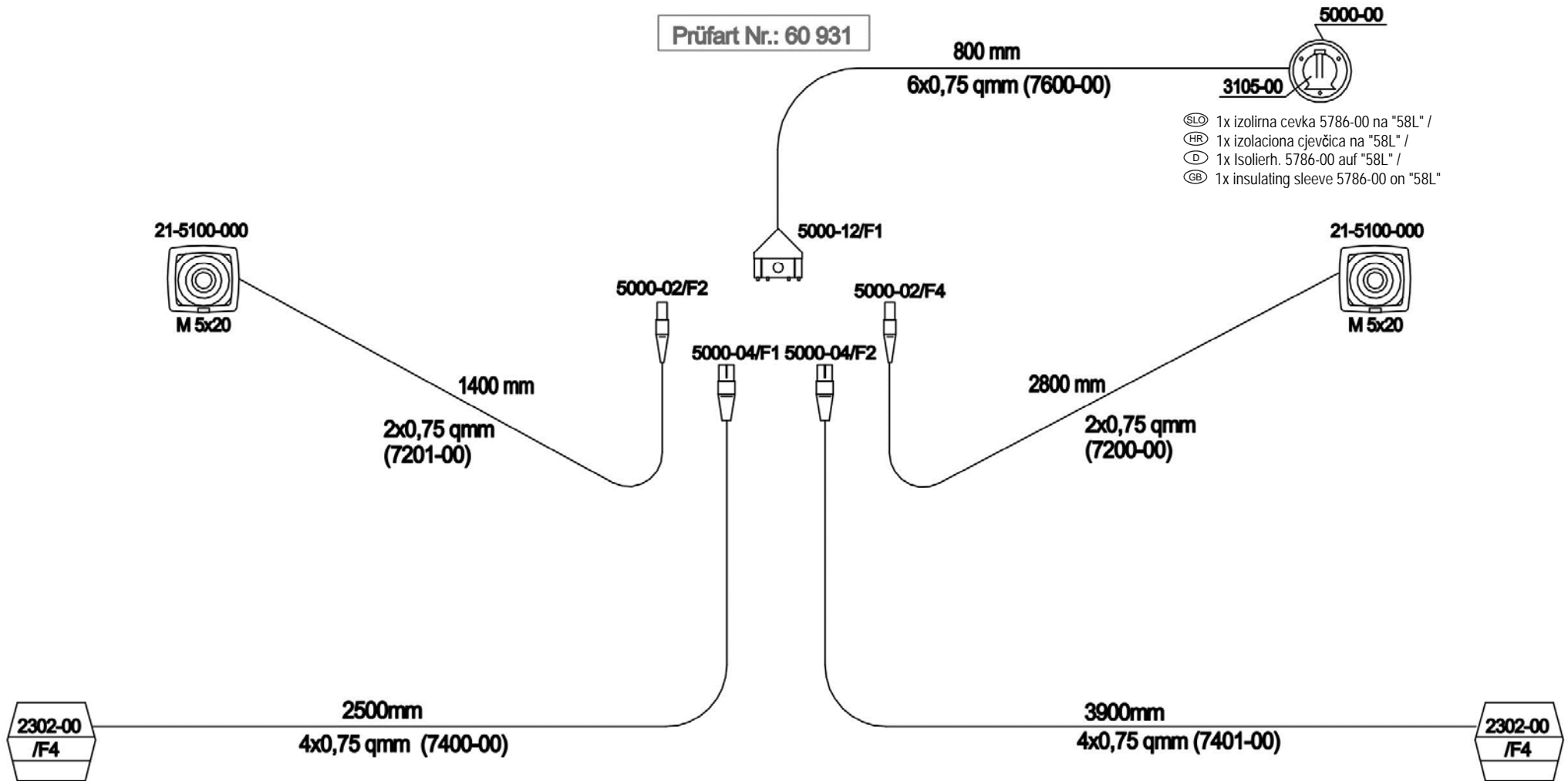

Oprema svetlobna  
Svetlosna oprema

Beleuchtung  
Electrical illumination

(12 VOLT)  
Ident: 764200950

Koda za naročilo.: AA-8240-08  
 Koda za narudžbu: AA-8240-08  
 Bestell-Nr.: AA-8240-08  
 Order No: AA-8240-08

**OPTICUT 220 F = +151**

DODATNA OPREMA SONDERAUSRÜSTUNG – ZUSATZTEILE ADDITIONAL EQUIPMENT ÉQUIPEMENT ADDITIONNEL ATTREZZATURA AGGIUNTIVA				Velja od tov. št. dalje: Váží od tvor. broja dalje: Ab masch. Nr.: From mach Nr.: Da macch. Nr.: N° de machine :				OPTICUT 220 F = +151		39a	
Številka Broj Bild Fig. Fig. N°	Kataloška številka Kataloški broj Ersatzteilnummer Spare Part Number Numero Parti di Ricambio Número de la pièce de rechange	Naziv dela (SLO)	Naziv dijela (HR)	Benennung (D)	Description (GB)	Descrizione (I)	Description (F)		Količina Komada Menge Quantity Quantità Quantité		
	764200950	Svetlobna oprema (ASPOCK)	Svetlosna oprema (ASPOCK)	Beleuchtung (ASPOCK)	Electrical illumination (ASPOCK)	Illuminazione elettrica (ASPOECK)	Illumination électrique (ASPOECK)		1		

	DODATNA OPREMA:	(SLO) (CRO)
4 kos	4808-00	odklopnik/ otkačnik
2 kos	5411-01	odsevník/60mm/samolepilni/ refleksijsko staklo /60mm /samoljepilno
2 kos	5410-01	odsevník/60mm/samolepilni/ refleksijsko staklo /60mm /samoljepilno
8 kos	S500-00	matica M5/ mática M5
8 kos	S502-00	zubata podložka M5/ zubata podložka M5

	ZUBEHÖR / ACCESSORIES:	(D) (GB)
4 Stk. / pcs	4808-00	Zugentlastungen/ strain relief
2 Stk. / pcs	5411-01	Strahler rt/60mm/selbstkl. spotlight /60 mm/ selfadhesive
2 Stk. / pcs	5410-01	Strahler ws/60mm/selbstkl. spotlight /60 mm/ selfadhesive
8 Stk. / pcs	S500-00	Muttern M5/ Screw nut M5
8 Stk. / pcs	S502-00	Zahnscheiben M5/ tooth lock washer M5

Prüfart Nr.: 60 931

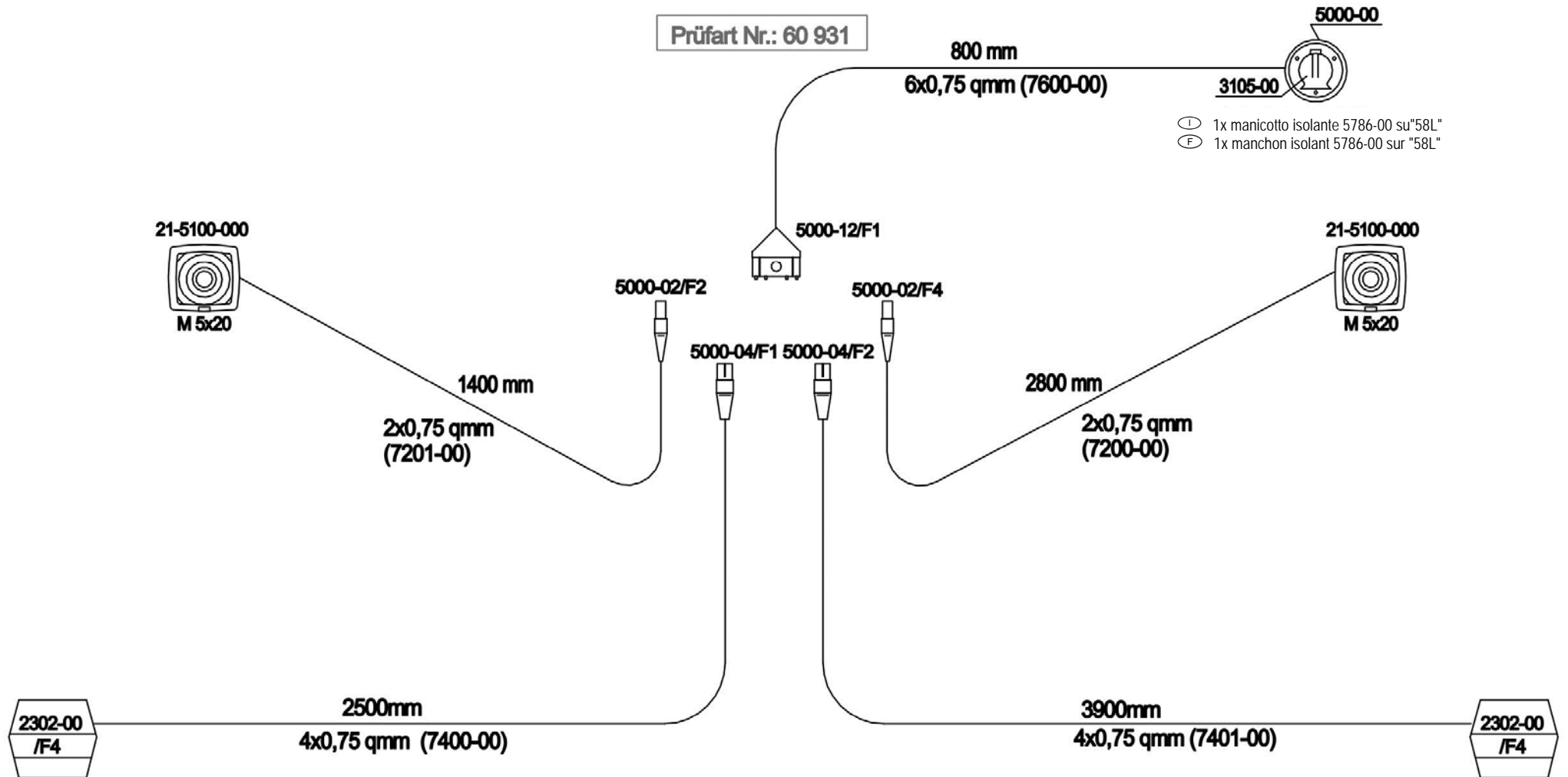

(I) 1x manicotto isolante 5786-00 su "58L"  
 (F) 1x manchon isolant 5786-00 sur "58L"

DODATNA OPREMA SONDERAUSRÜSTUNG – ZUSATZTEILE ADDITIONAL EQUIPMENT ÉQUIPEMENT ADDITIONNEL ATTREZZATURA AGGIUNTIVA				Velja od tov. št. dalje: Váží od tvor. broja dalje: Ab masch. Nr.: From mach Nr.: Da macch. Nr.: N° de machine :				OPTICUT 220 F = +151		39a	
Številka Broj Bild Fig. Fig. N°	Kataloška številka Kataloški broj Ersatzteilnummer Spare Part Number Numero Parti di Ricambio Número de la pièce de rechange	Naziv dela (SLO)	Naziv dijela (HR)	Benennung (D)	Description (GB)	Descrizione (I)	Description (F)		Količina Komada Menge Quantity Quantità Quantité		
	764200950	Svetlobna oprema (ASPOCK)	Svetlosna oprema (ASPOCK)	Beleuchtung (ASPOCK)	Electrical illumination (ASPOCK)	Illuminazione elettrica (ASPOECK)	Illumination électrique (ASPOECK)		1		

ACCESSORI: (I)		
4 pez.	4808-00	serracavo:
2 pez.	5411-01	faretto/60 mm/autoadesivo
2 pez.	5410-01	faretto/60 mm/autoadesivo
8 pez.	S500-00	dado M5
8 pez.	S502-00	rondella blocca denti M5

ACCESSOIRES: (F)		
4 pcs	4808-00	détente de la contrainte
2 pcs	5411-01	projecteur/60 mm/ auto-adhésif
2 pcs	5410-01	projecteur/60 mm/ auto-adhésif
8 pcs	S500-00	Vis écrou M5.
8 pcs	S502-00	rondelle à dents M5

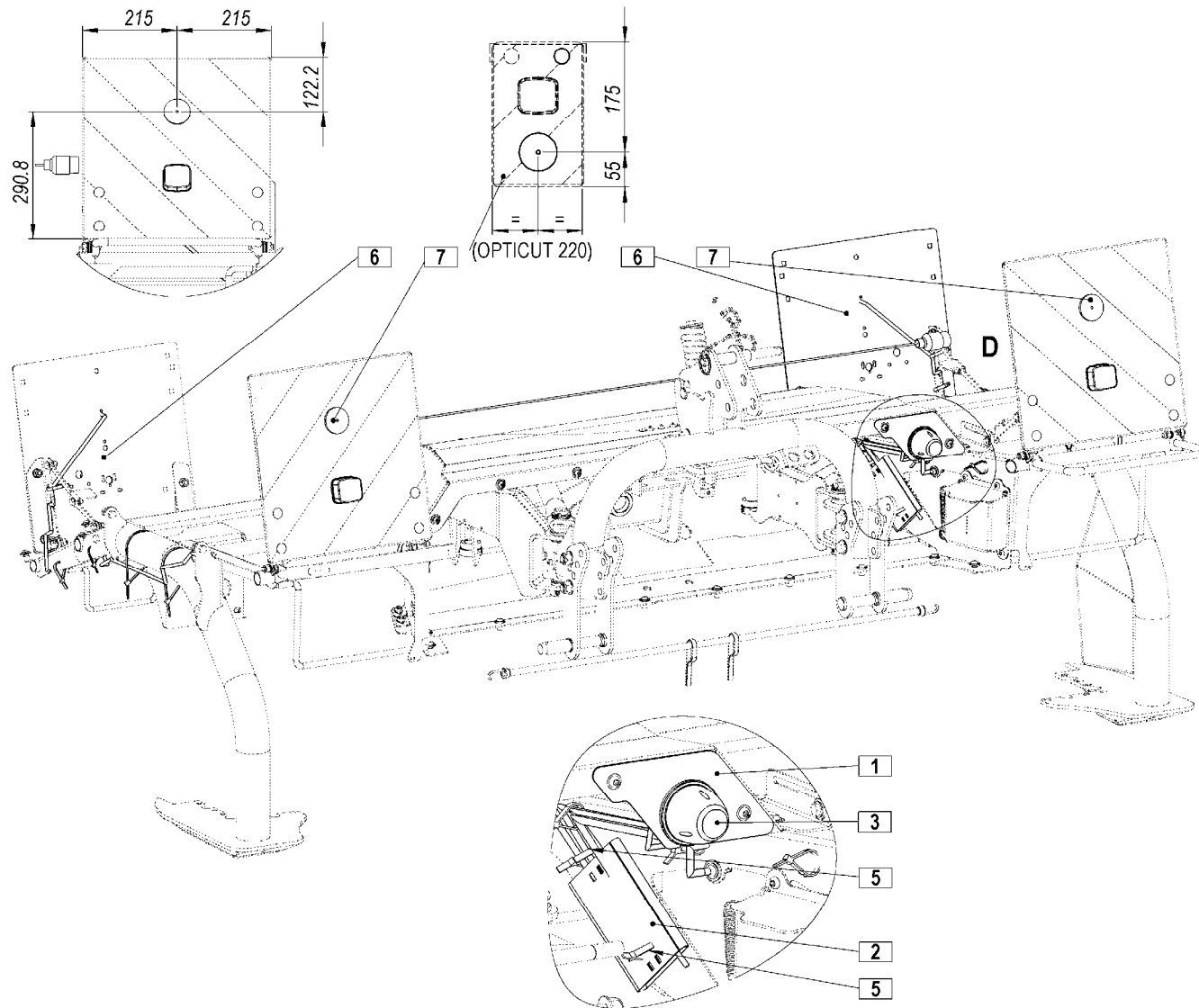



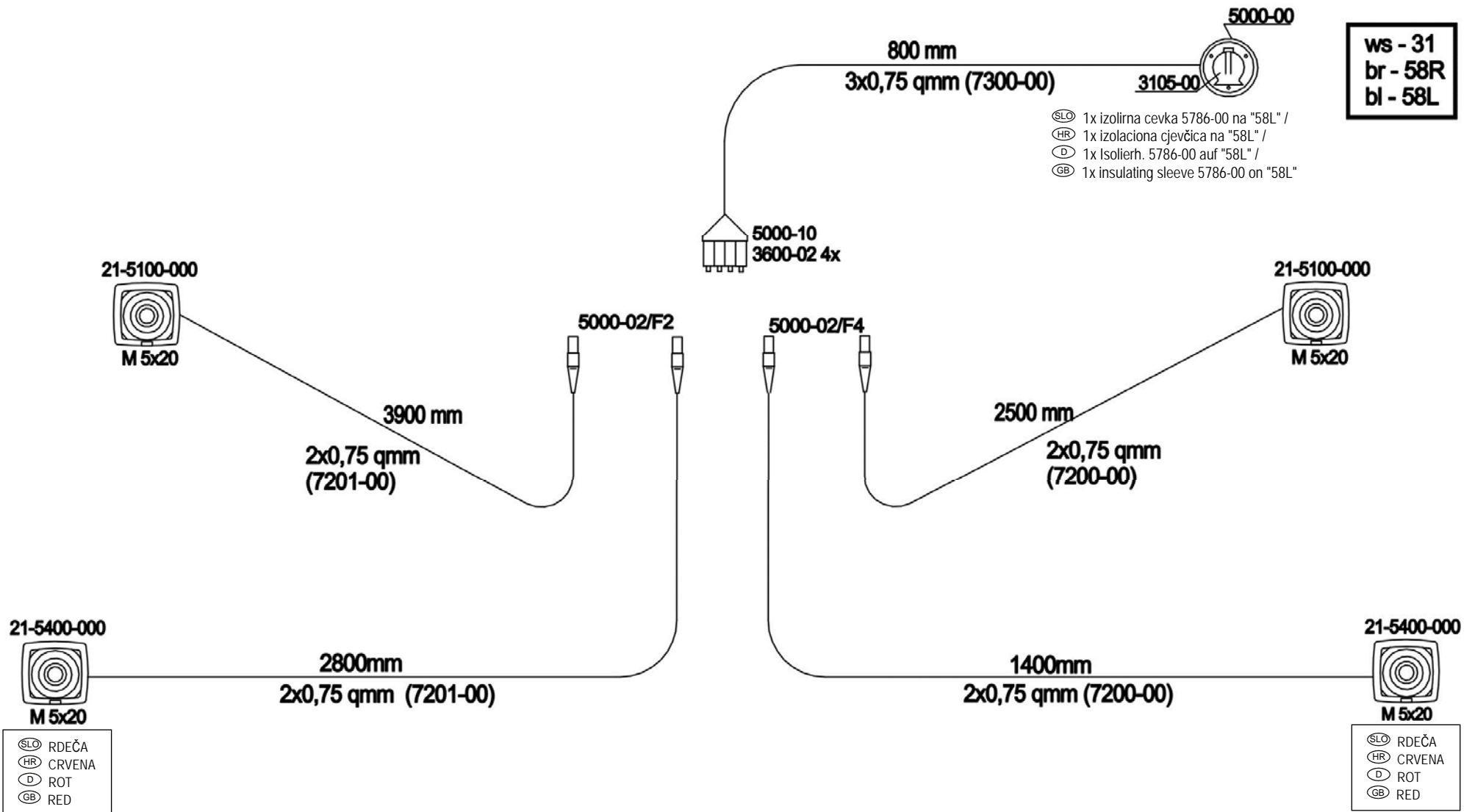

Oprema svetlobna  
Svetlosna oprema

Beleuchtung  
Electrical illumination

(12 VOLT)  
Ident: 764200960

Koda za naročilo.: AA-8240-09  
Koda za narudžbu: AA-8240-09  
Bestell-Nr.: AA-8240-09  
Order No: AA-8240-09

**OPTICUT 220 F = +151**



DODATNA OPREMA SONDERAUSRÜSTUNG – ZUSATZTEILE ADDITIONAL EQUIPMENT ÉQUIPEMENT ADDITIONNEL ATTREZZATURA AGGIUNTIVA				Velja od tov. št. dalje: Važi od tvor. broja dalje: Ab masch. Nr.: From mach. Nr.: Da macch. Nr.: N° de machine :				OPTICUT 220 F = +151		40a	
Številka Broj Bild Fig. Fig. N°	Kataloška številka Kataloški broj Ersatzteilnummer Spare Part Number Numero Parti di Ricambio Número de la pièce de rechange	Naziv dela (SLO)	Naziv dijela (HR)	Benennung (D)	Description (GB)	Descrizione (I)	Description (F)			Količina Komada Menge Quantity Quantità Quantité	
	764200960	Svetlobna oprema (ASPOCK)	Svetlosna oprema (ASPOCK)	Beleuchtung (ASPOCK)	Electrical illumination (ASPOCK)	Illuminazione elettrica (ASPOECK)	Illuminazione électrique (ASPOECK)			1	

	DODATNA OPREMA:	(SLO) (CRO)
4 kos	4808-00	odklopnik/ otkačnik
2 kos	5411-01	odsevník/60mm/samolepilni/ refleksijsko staklo /60mm /samoljepilno
2 kos	5410-01	odsevník/60mm/samolepilni/ refleksijsko staklo /60mm /samoljepilno
8 kos	S500-00	matica M5/ mática M5
8 kos	S502-00	zubata podložka M5/ zubata podložka M5

	ZUBEHÖR / ACCESSORIES:	(D) (GB)
4 Stk. / pcs	4808-00	Zugentlastungen/ strain relief
2 Stk. / pcs	5411-01	Strahler rt/60mm/selbstkl. spotlight /60 mm/ selfadhesive
2 Stk. / pcs	5410-01	Strahler ws/60mm/selbstkl. spotlight /60 mm/ selfadhesive
8 Stk. / pcs	S500-00	Muttern M5/ Screw nut M5
8 Stk. / pcs	S502-00	Zahnscheiben M5/ tooth lock washer M5

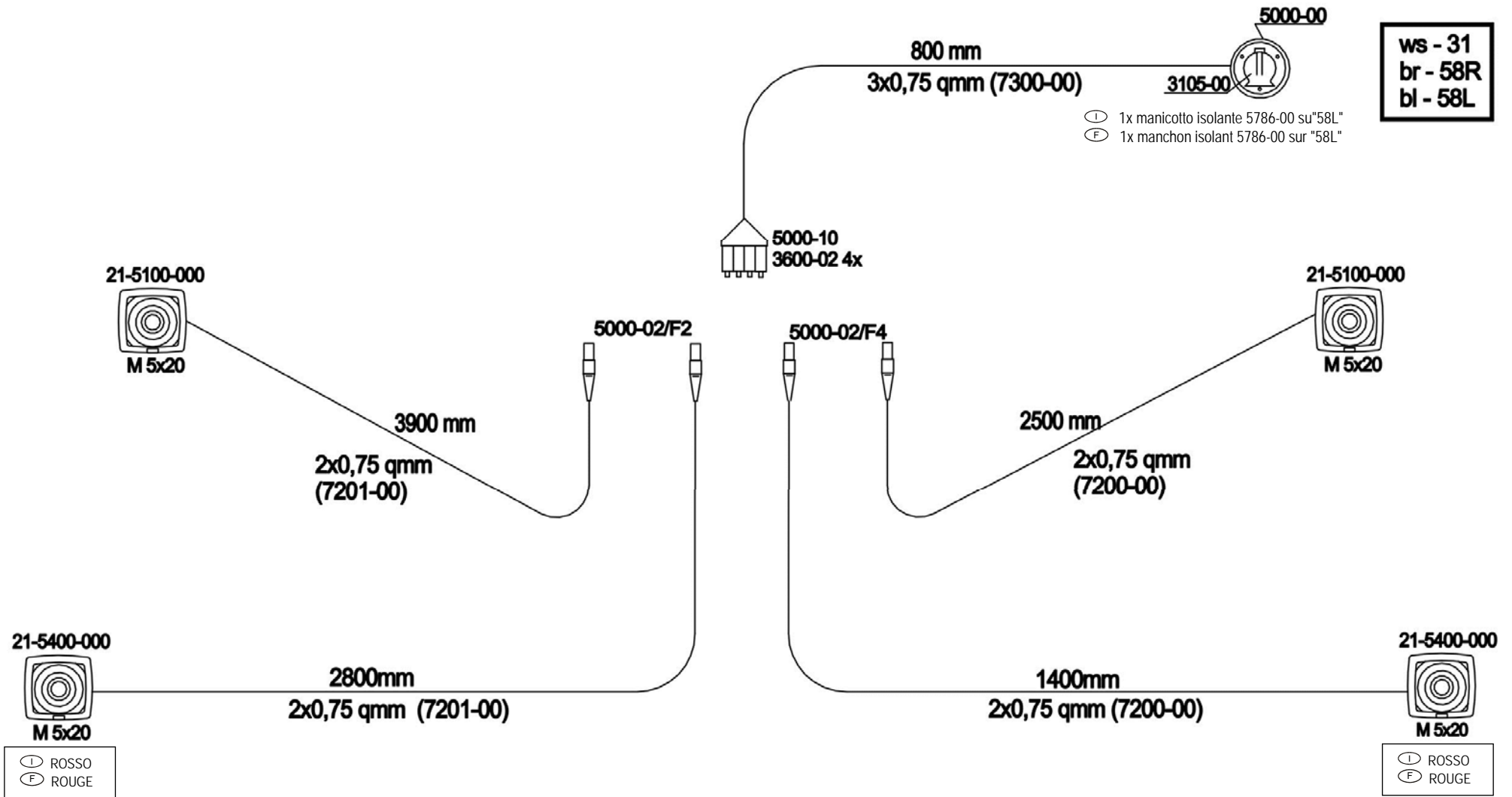

DODATNA OPREMA SONDERAUSRÜSTUNG – ZUSATZTEILE ADDITIONAL EQUIPMENT ÉQUIPEMENT ADDITIONNEL ATTREZZATURA AGGIUNTIVA				Velja od tov. št. dalje: Važi od tvor. broja dalje: Ab masch. Nr.: From mach Nr.: Da macch. Nr.: N° de machine :				OPTICUT 220 F = +151		40a	
Številka Broj Bild Fig. Fig. N°	Kataloška številka Kataloški broj Ersatzteilnummer Spare Part Number Numero Parti di Ricambio Numéro de la pièce de rechange	Naziv dela (SLO)	Naziv dijela (HR)	Benennung (D)	Description (GB)	Descrizione (I)	Description (F)			Količina Komada Menge Quantity Quantità Quantité	
	764200960	Svetlobna oprema (ASPOCK)	Svetlosna oprema (ASPOCK)	Beleuchtung (ASPOCK)	Electrical illumination (ASPOCK)	Illuminazione elettrica (ASPOECK)	Illumination électrique (ASPOECK)			1	

	ACCESSORI:	(I)
4 pez.	4808-00	serracavo:
2 pez.	5411-01	faretto/60 mm/autoadesivo
2 pez.	5410-01	faretto/60 mm/autoadesivo
8 pez.	S500-00	dado M5
8 pez.	S502-00	rondella blocca denti M5

	ACCESSOIRES:	(F)
4 pcs	4808-00	détente de la contrainte
2 pcs	5411-01	projecteur/60 mm/ auto-adhésif
2 pcs	5410-01	projecteur/60 mm/ auto-adhésif
8 pcs	S500-00	Vis écrou M5.
8 pcs	S502-00	rondelle à dents M5

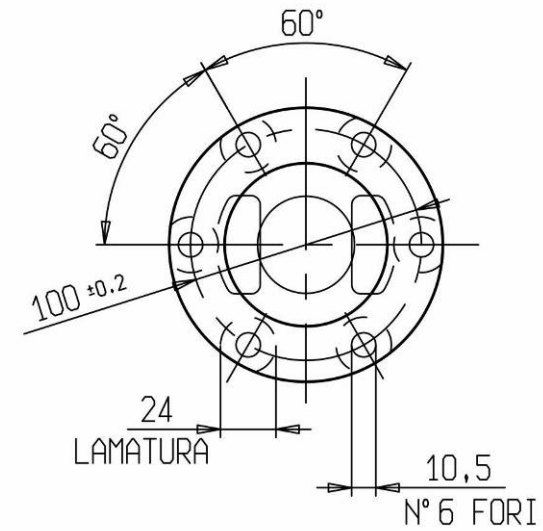
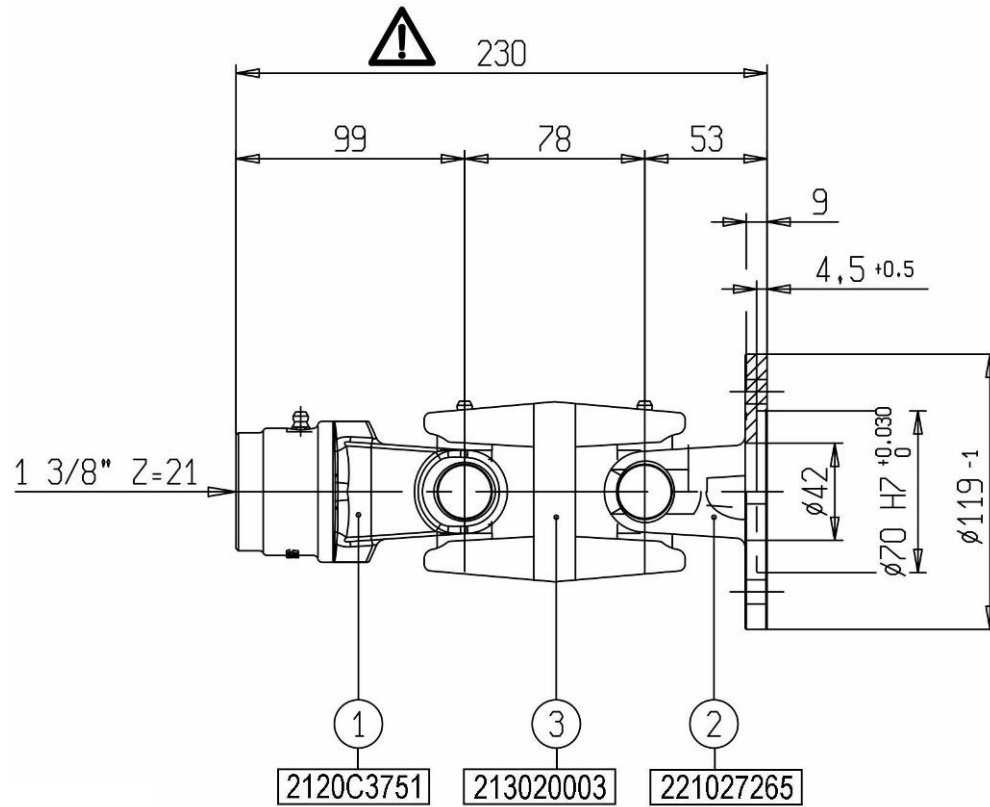

KARDAN.112.0

Ident: 150676806

KARDAN.112.0  
GELENKWELLE.112.0

Ident: 150676806

P.T.O. SHAFT.112.0  
ALBERO CARDANICO.112.0

ARBRE DE TRANSMISSION.112.0

OPTICUT 220 F = +151

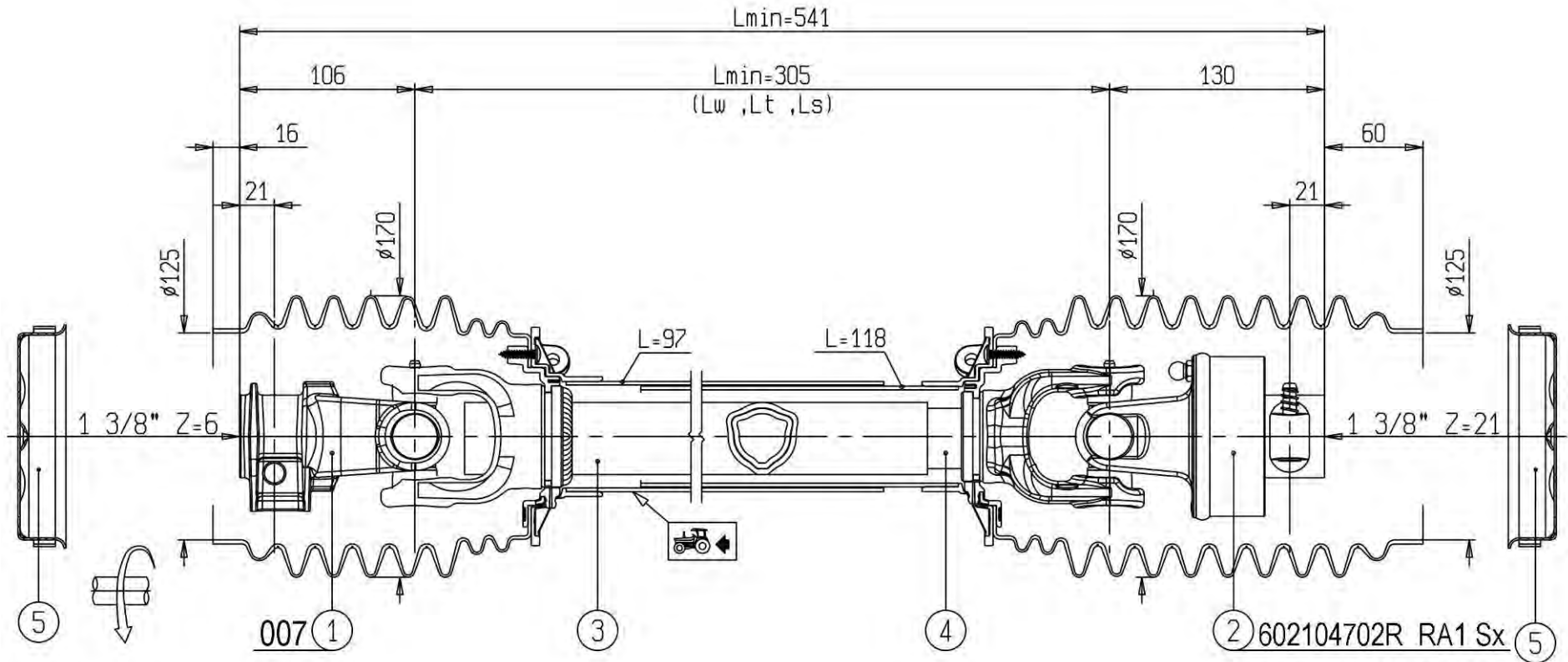

KARDAN.117.0

Ident: 150697801

KARDAN.117.0  
GELENKWELLE.117.0

Ident: 150697801

P.T.O. SHAFT.117.0  
ALBERO CARDANICO.117.0

ARBRE DE TRANSMISSION.117.0

OPTICUT 220 F = +151

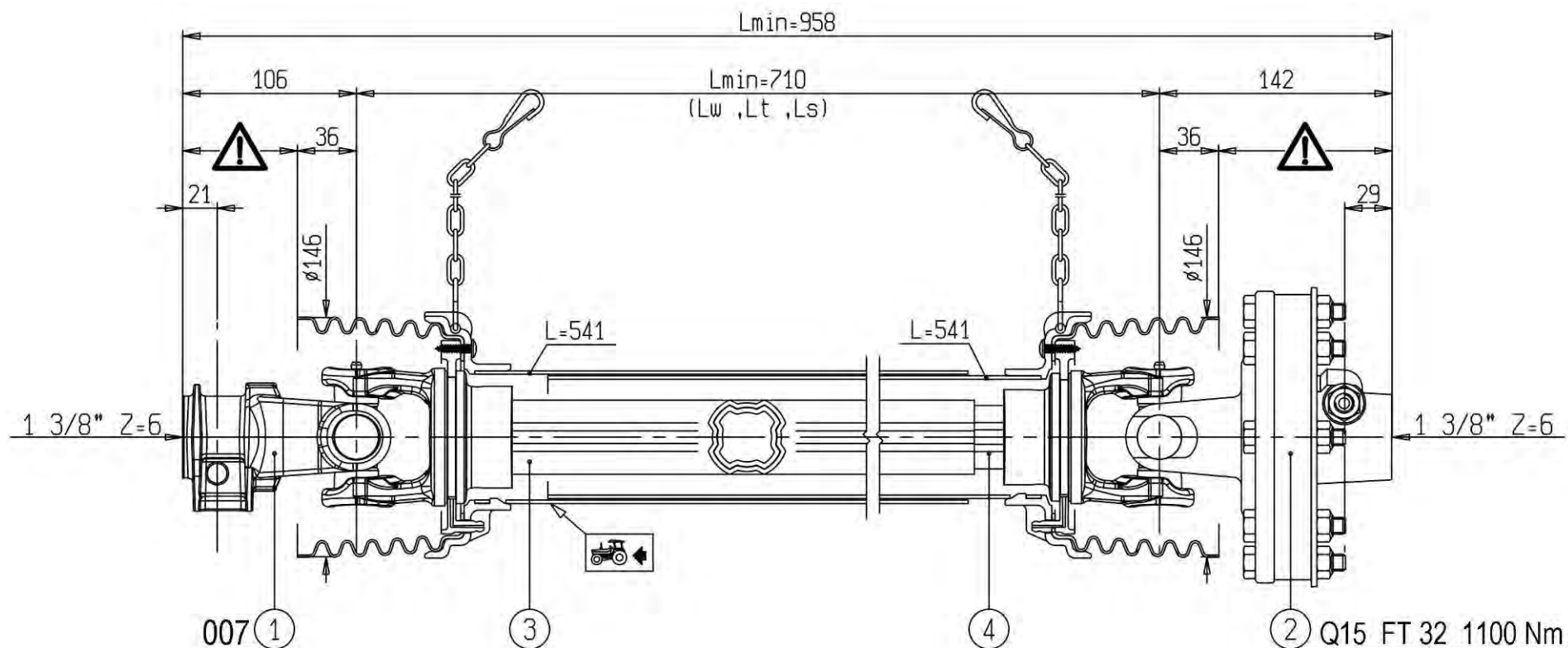

KARDAN.118.0

Ident: 150697909

KARDAN.118.1

Ident: 150706908

KARDAN.118.0  
GELENKWELLE.118.0

Ident: 150697909

KARDAN.118.1  
GELENKWELLE.118.1

Ident: 150706908

P.T.O. SHAFT.118.0  
ALBERO  
CARDANICO.118.0

ARBRE DE  
TRANSMISSION.118.0

P.T.O. SHAFT.118.1  
ALBERO  
CARDANICO.118.1

ARBRE DE  
TRANSMISSION.118.1

OPTICUT 220 F = +151

**SIP**

# POGODBENI SERVISI

**SIP**

## SLOVENIJA

<b>SIP ŠEMPETER d.d.</b> 3311 ŠEMPETER V SAVINJSKI DOLINI Tel: 03 70 38 500 Reklamacije: (0)3 70 38 562 Fax: 03 70 38 665	<b>SMOLIČ JOŽE</b> Artmanja vas 7, 8211 DOBRNIČ Tel: 07 34 65 600 Fax: 07 34 65 389 GSM: 041 693 221	<b>KMETIJSTVO POLANEC d.o.o.</b> Pleterje 34 2324 LOVRENC NA DRAVSKEM POLJU Tel: 02 761 9300 Fax: 02 761 9306
<b>KMETIJSKI CENTER LAH</b> Klanec 13 1218 KOMENDA Tel: 01 8341 022 Tel: 01 8342 070 Tel: 01 8342 080 Tel: 01 8342 212 Fax: 01 8345 505	<b>RIKOTECH d.o.o.</b> Lepovče 23, 1310 RIBNICA Tel. / fax.: 01 83 61 483 GSM: 041 72 43 98	<b>AVTO CENTER ORMOŽ d.o.o.</b> Hardek 44/c, 2270 ORMOŽ Fax: 02 7416 410 Tel: 02 74 16 405 (servis) GSM: 031 322 939 Tel: 02 74 16 407 (trgovina) GSM: 031 891 529
<b>CREINA KRANJ</b> Vodnova 8, 4000 KRANJ Tel: 04 20 13 360 (centrala) Tel: 04 20 13 355 (servis) Fax: 04 20 13 363	<b>KZ KRKA z.o.o.</b> <b>OC AGROSERVIS Novo Mesto</b> Knafelčeva 2 8000 NOVO MESTO Tel: 07 393 01 11 Fax: 07 393 01 25 Tel: 07 393 01 10	<b>ŽIBRAT JANI</b> Mota 32, 9240 LJUTOMER Tel: 02 584 1130 Fax: 02 584 1130 GSM: 041 713 300
<b>AVTO ERŽEN d.o.o.</b> Podjelovo Brdo 1, 4225 SOVODENJ Tel: 04 510 80 70 Fax: 04 510 80 77 GSM: 041 721 706	<b>JAKŠE SAMO</b> Prvomajska c. 22 8310 ŠENTJERNEJ Fax / Tel: 07 3081 309	<b>FRANC ŠTAMUL s.p.</b> Vuhred 125 2365 VUHRED Fax / Tel: 02 88 73 751 GSM: 041 332 684
	<b>TOMC MARJAN</b> Primostek 6 8332 GRADAC Tel: 07 30 58 513 GSM: 041 685 133	

## HRVAŠKA

<b>MF SERVIS</b> Filipčić Milorad Gradec 9, 10345 GRADEC Tel: ++385 01 897 058 GSM: 098 248 267	<b>PROIZVODNA OPRUGA DEŽANOVAC</b> DEŽANOVAC Tel: ++385 43 381 333 Tel: ++385 43 381 366 (trgovina) Fax: ++385 43 381 330	<b>AGM PANEX ČAKOVEC</b> Zagrebačka 101, 40300 ČAKOVEC Tel: ++385 40 384 144 Tel: ++385 40 384 354 Tel: ++385 40 384 351 (servis) Fax: ++385 40 384 355
<b>BOŽIĆ VLADO</b> Brače Radiča 50 42232 MARTIJANEC Tel: ++385 42 673 020 GSM: 099 420 927	<b>ALKAR d.o.o.</b> Dubrovačka 67, 34000 POŽEGA Tel: ++385 34 274 671 Fax: ++385 34 273 433 GSM: 098 362 996 GSM: 098 365 211	<b>ALSO d.o.o.</b> Končanica 355 43505 KONČANICA Tel: ++385 43 325 124 GSM: 091 56 13 600

## BOSNA IN HERCEGOVINA

<b>P.P. MABI</b> Mrkodol h.h. 80240 TOMISLAVGRAD Tel: ++387 34 310 100	<b>AGROCOOP KOBATOVCI</b> 78255 BOSANSKI ALEKSANDROVAC Tel: ++387 51 582 041 (servis) GSM: ++387 65 510 290, Fax: ++387 51 580 800	<b>ACMA d.o.o.</b> Ljusina b.b. 77244 BOS. OTOKA Tel: ++387 37 477 018 Fax: ++387 37 477 039 GSM: ++387 61 155 905
---	---	---

## SRBIJA IN ČRNA GORA

<b>AGRO DRINIA</b> 38400 PRIZREN KOSOVO Tel / Fax: ++381 29 44 335 GSM: ++377 44 113 137	<b>JUGOMETAL d.o.o.</b> Kušljevački put b.b., 35210 SVILAJNAC Tel: ++381 35 312 391 Tel: ++381 35 312 027 Tel: ++381 35 311 696, Fax: ++381 35 312 331	<b>AGROAUTO PODGORICA</b> Ul. Bracana Bracanoviča 76 81412 SPUŽ Tel: ++381 81 881 784 Fax: ++381 81 636 290
--	--	---

## MAKEDONIJA

	<b>EURO POLOG</b> 1226 Zheline, TETOVO Tel: ++389 44 379 379, Fax: ++389 44 378 236	
--	---	--

SIP d.d. Šempeter si pridržuje pravico do morebitnih sprememb v katalogu