

(SLO) Seznam nadomestnih delov

(HR) Spisak rezervnih delov

(GB) Spare parts list

(D) Ersatzteilliste

(I) Lista parti di ricambio

(F) Liste des pièces de rechange

SIP™

OPTICUT DISC 260 F ALP

diskasti rotacijski kosilnik
diskasta rotaciona kosačica
falciatrice a disco rotante

rotary disc mower
scheibenmähwerke
faucheuse à disque rotatif

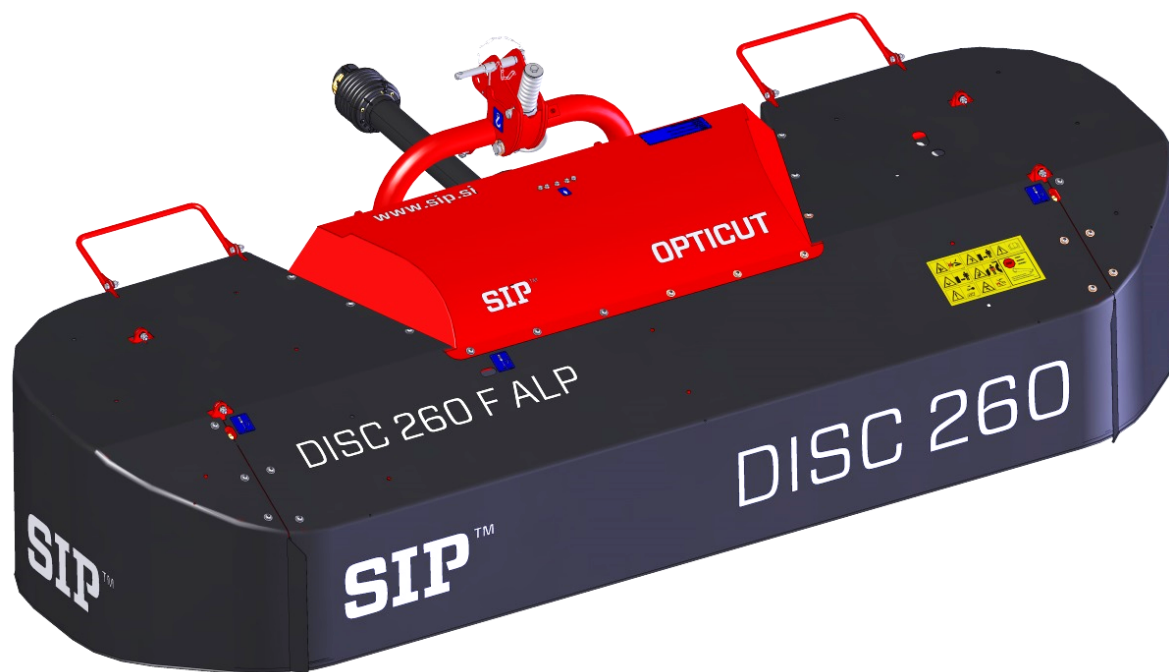

Velja od tov. št. dalje:
Važi od tvor. broja dalje:
Ab masch. Nr.:
From mach Nr.:
Da macch. Nr.:
N° de machine:

OPTICUT DISC 260 F ALP = 197



STROJNA INDUSTRIJA d.d.
3311 Šempeter v Savinjski dolini
Slovenija

Tel: +386 (03) 7038 500
Fax: +386 (03) 7038 663
+386 (03) 7038 674

158449609

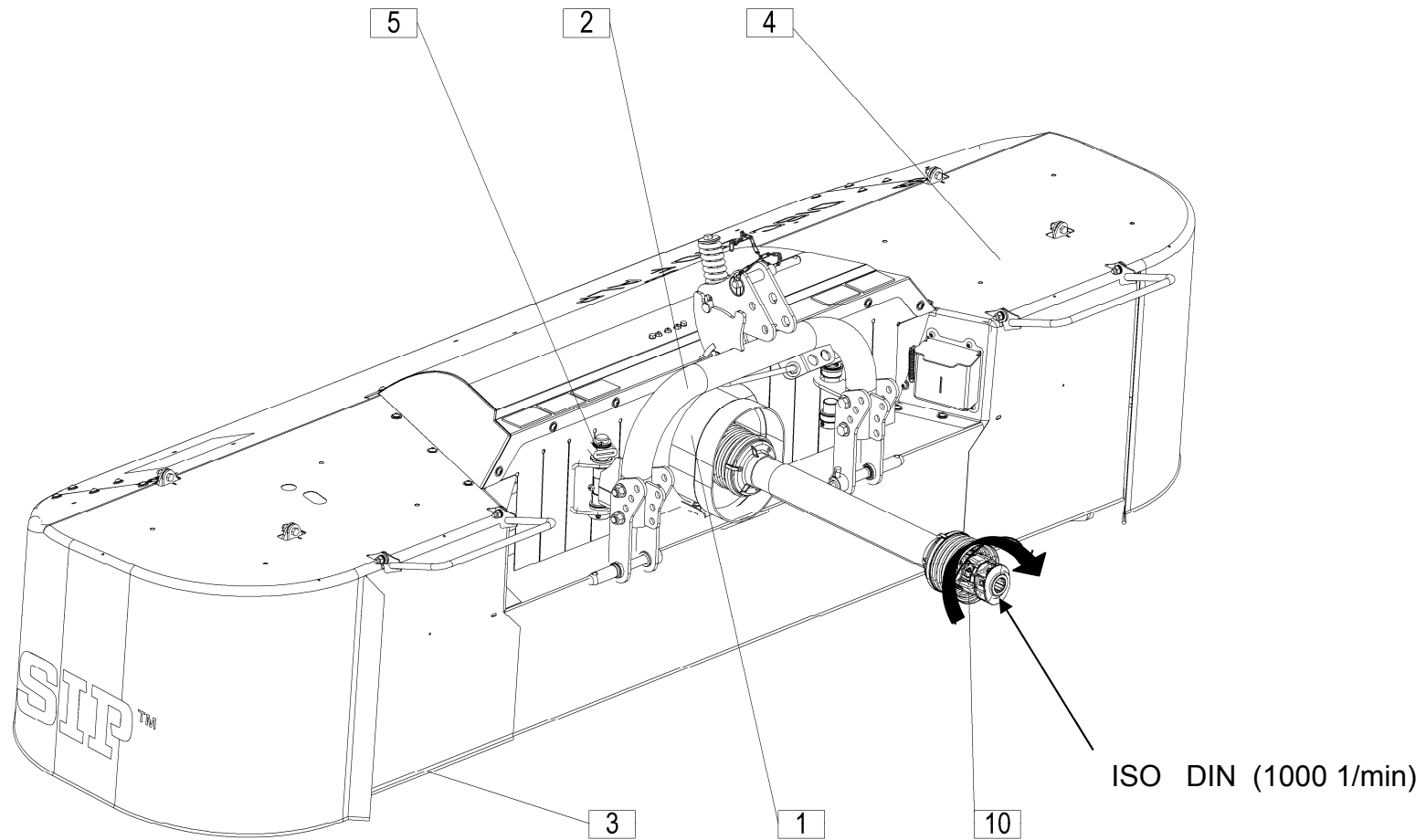

764.50.000.0 (DIN)
764.51.000.0 (ISO)

1000 min⁻¹

OPTICUT DISC 260 F ALP=+197

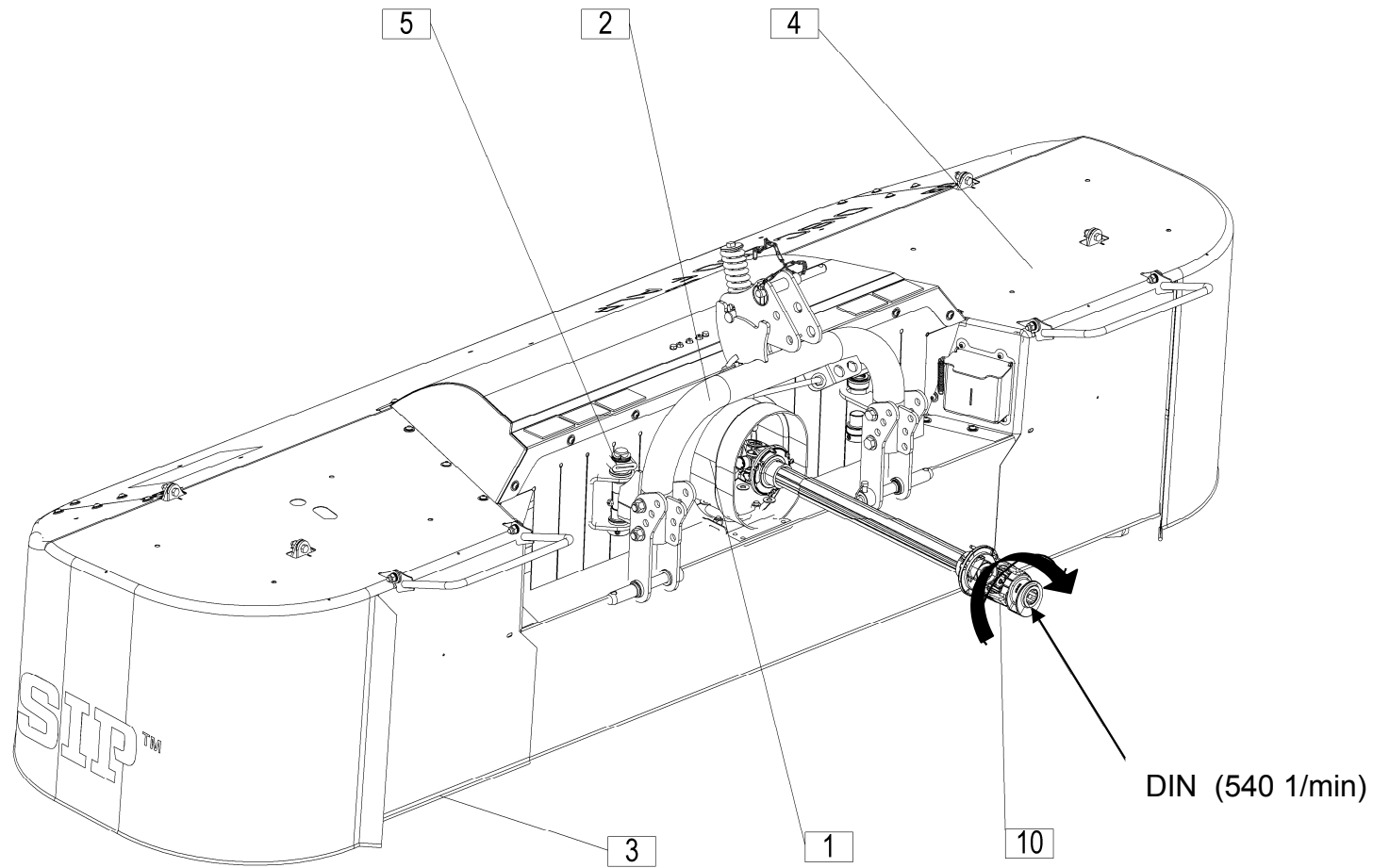

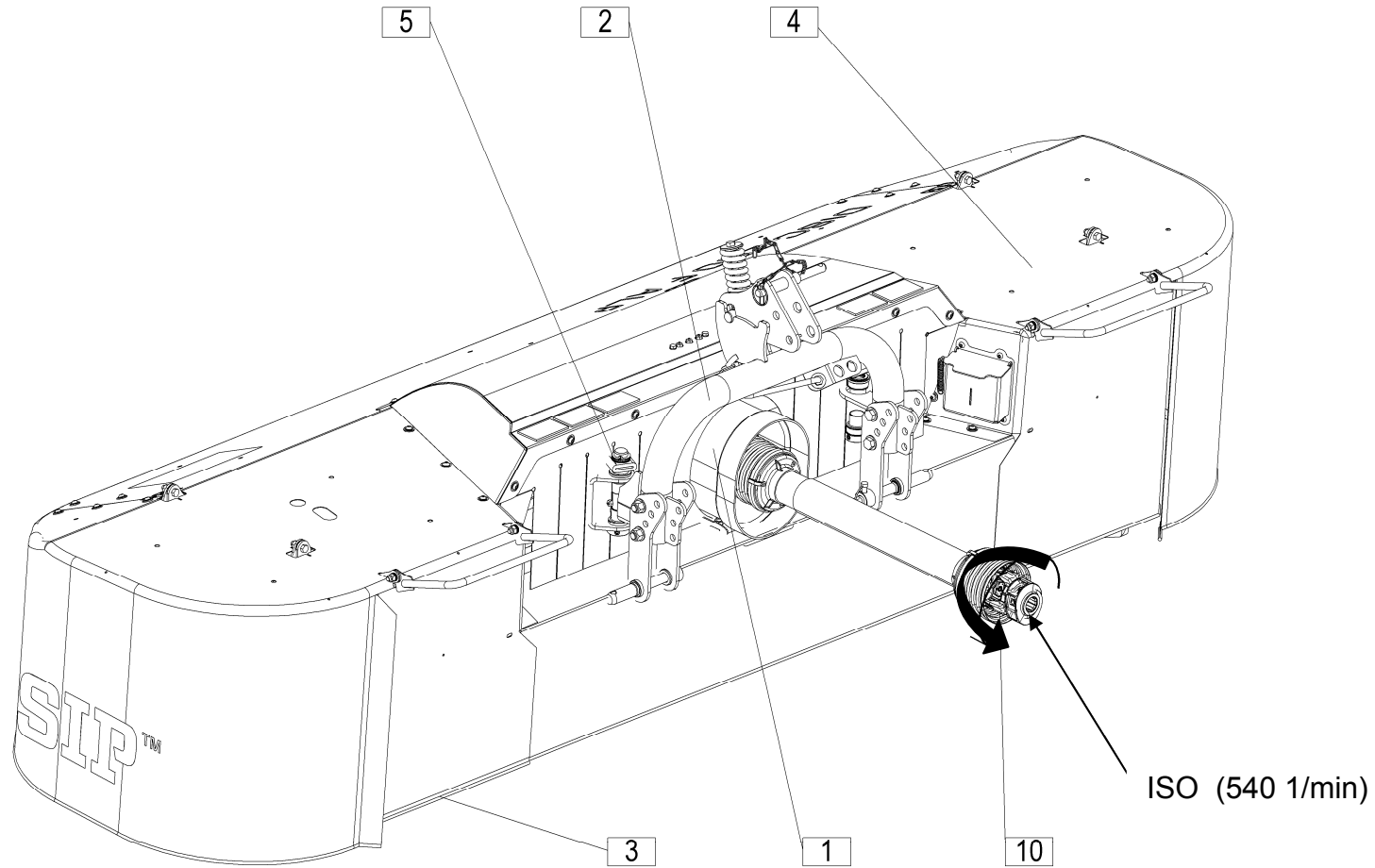

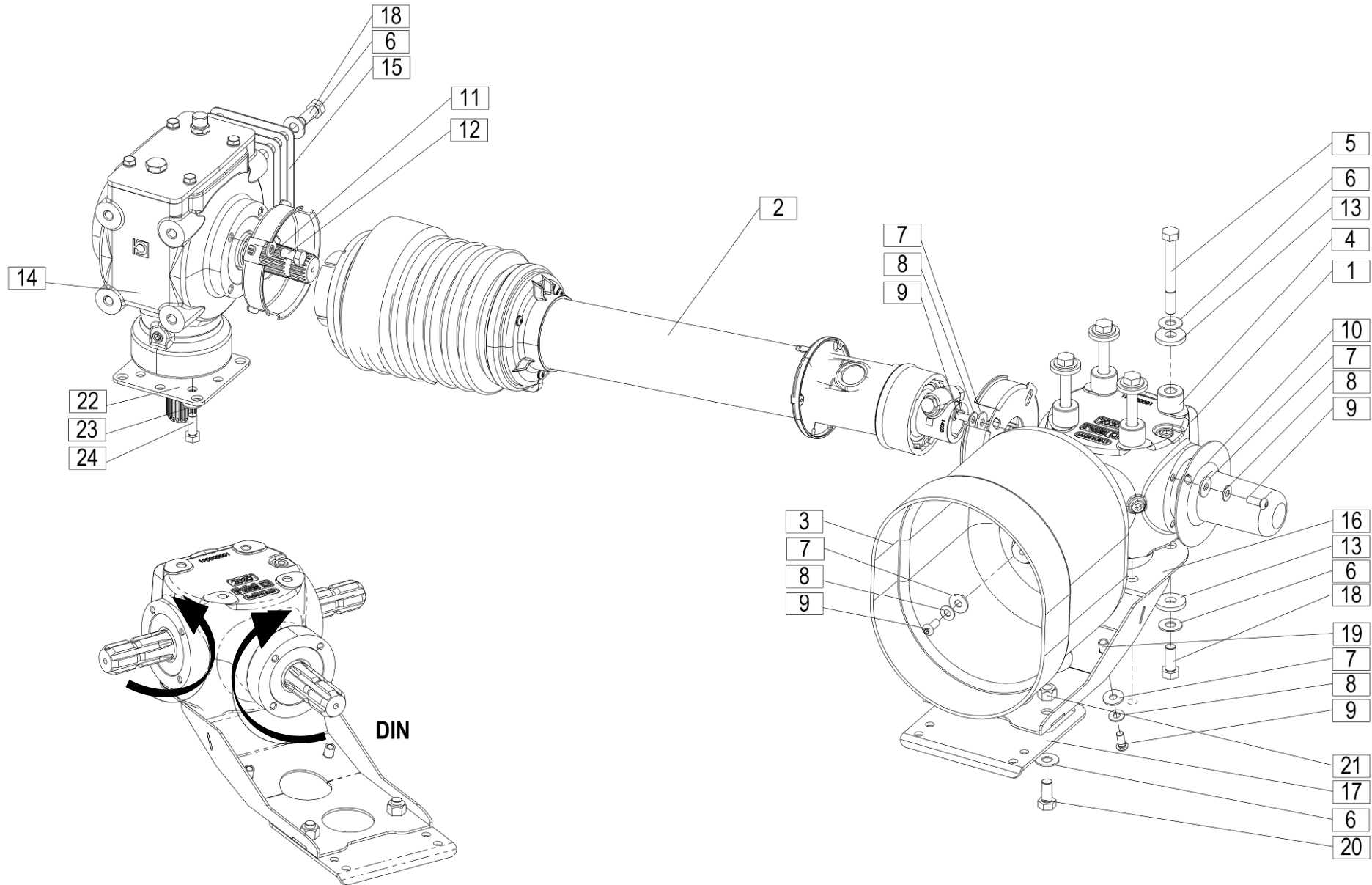

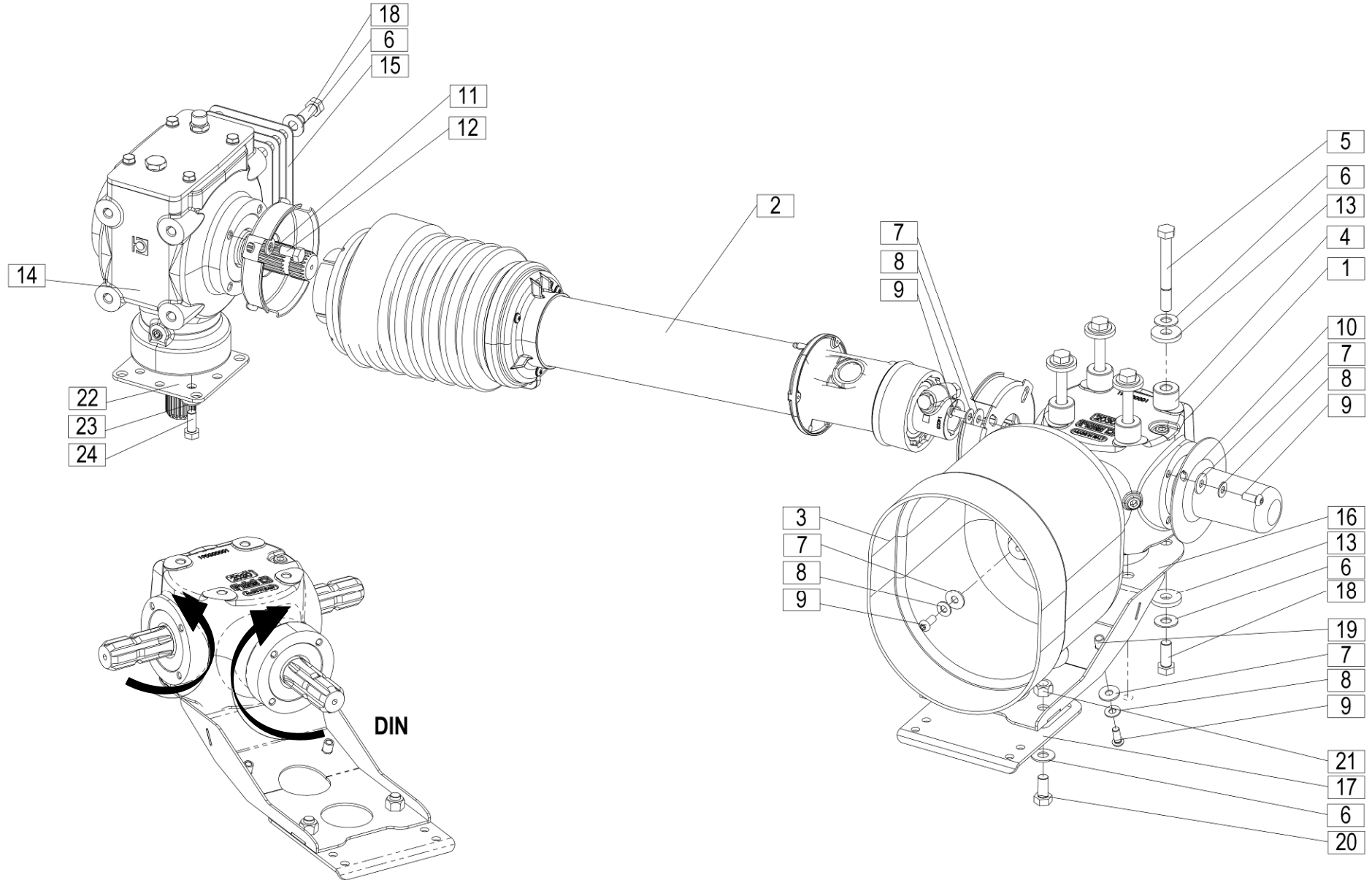

Številka Broj Bild Fig. Fig. N°		Katalogska številka Kataloški broj Ersatzteilnummer Spare Part Number Numero Parti di Ricambio Numéro de la pièce de rechange		Naziv dela (SLO)	Naziv dijela (HR)	Benennung (D)	Description (GB)	Descrizione (I)	Description (F)	Količina Komada Menge Quantity Quantità
		Predelava pogona iz 540 DIN v 1000 DIN /ISO	Prerada pogona iz 540 DIN u 1000 DIN /ISO	Umrüstung des Antriebs aus 540 DIN in 1000 DIN/ISO	Drive conversion from 540 DIN to 1000 DIN/ISO	Conversione di trasmissione da 540 DIN a 1000 DIN/ISO	Transformation de l'arbre de transmission de 540 DIN en 1000 DIN /ISO			
1	150683200B	Gonilo B&P GONILO.027.0	Reduktor B&P GONILO.027.0	Getriebe B&P GONILO.027.0	Gear-box B&P GONILO.027.0	Scatola ingranaggi B&P GONILO.027.0	Carter de transmission B&P GONILO.027.0			1
4	764010160	Puša	Čaura	Büchse	Sleeve	Manicotto	Manchon			4
5	150229700	Vijak M12x100	Vijak M12x100	Schraube M12x100	Screw M12x100	Vite M12x100	Vis M12x100			4
7	150084401	Podložka C 8 Zn-100 HV	Podložka C 8 Zn-100 HV	Scheibe C 8 Zn-100 HV	Washer C 8 Zn-100 HV	Rondella C 8 Zn-100 HV	Rondelle C 8 Zn-100 HV			10
8	150426701	Podložka SKM 8	Podložka SKM 8	Scheibe SKM 8	Washer SKM 8	Rondella SKM 8	Rondelle SKM 8			10
9	150688802	Vijak M8x20	Vijak M8x20	Schraube M8x20	Screw M8x20	Vite M8x20	Vis M8x20			10
10	150653509	Zaščita gredi – plastična ByPy 240000630	Zaštita vratila – plastična ByPy 240000630	Welleschutz – Plastik ByPy 240000630	Shaft Protection – Plastic ByPy 240000630	Protezione plastica dell'albero ByPy 240000630	Arbre de transmission Protection – Plastique ByPy 240000630			1
16	764010190B	Nosilec var.	Nosač var.	Träger geschw.	Holder welded	Supporto saldato	Support soudé			1

DODATNA OPREMA
SONDERAUSRÜSTUNG – ZUSATZTEILE
ADDITIONAL EQUIPMENT
ÉQUIPEMENT ADDITIONNEL
ATTREZZATURA AGGIUNTIVA

151500101

Velja od tov. št. dalje:
Važi od tvor. broja dalje:
Ab masch. Nr.:
From mach Nr.:
Da macch. Nr.:
N° de machine :

OPTICUT DISC 260 F ALP=+197

4a

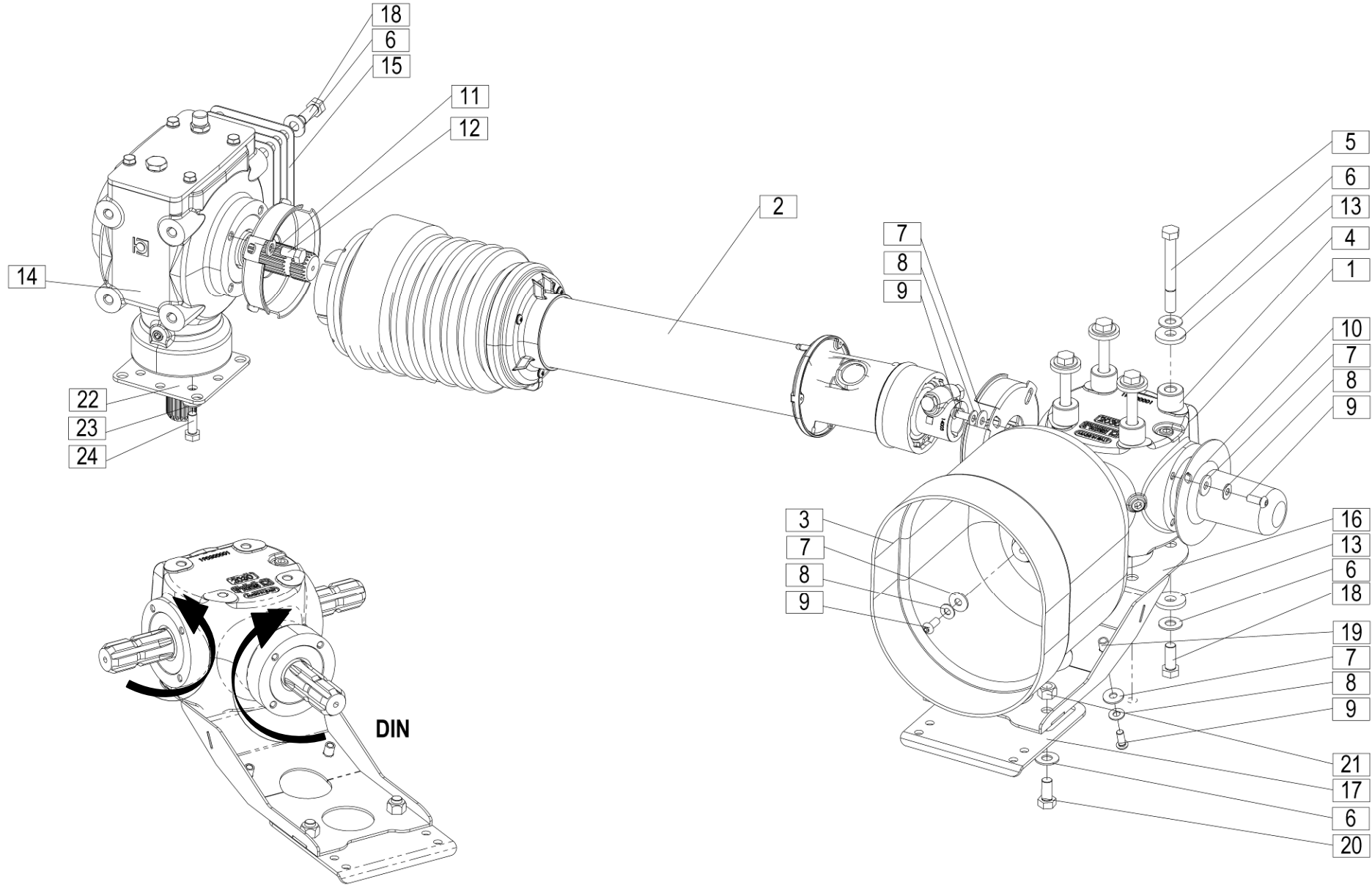

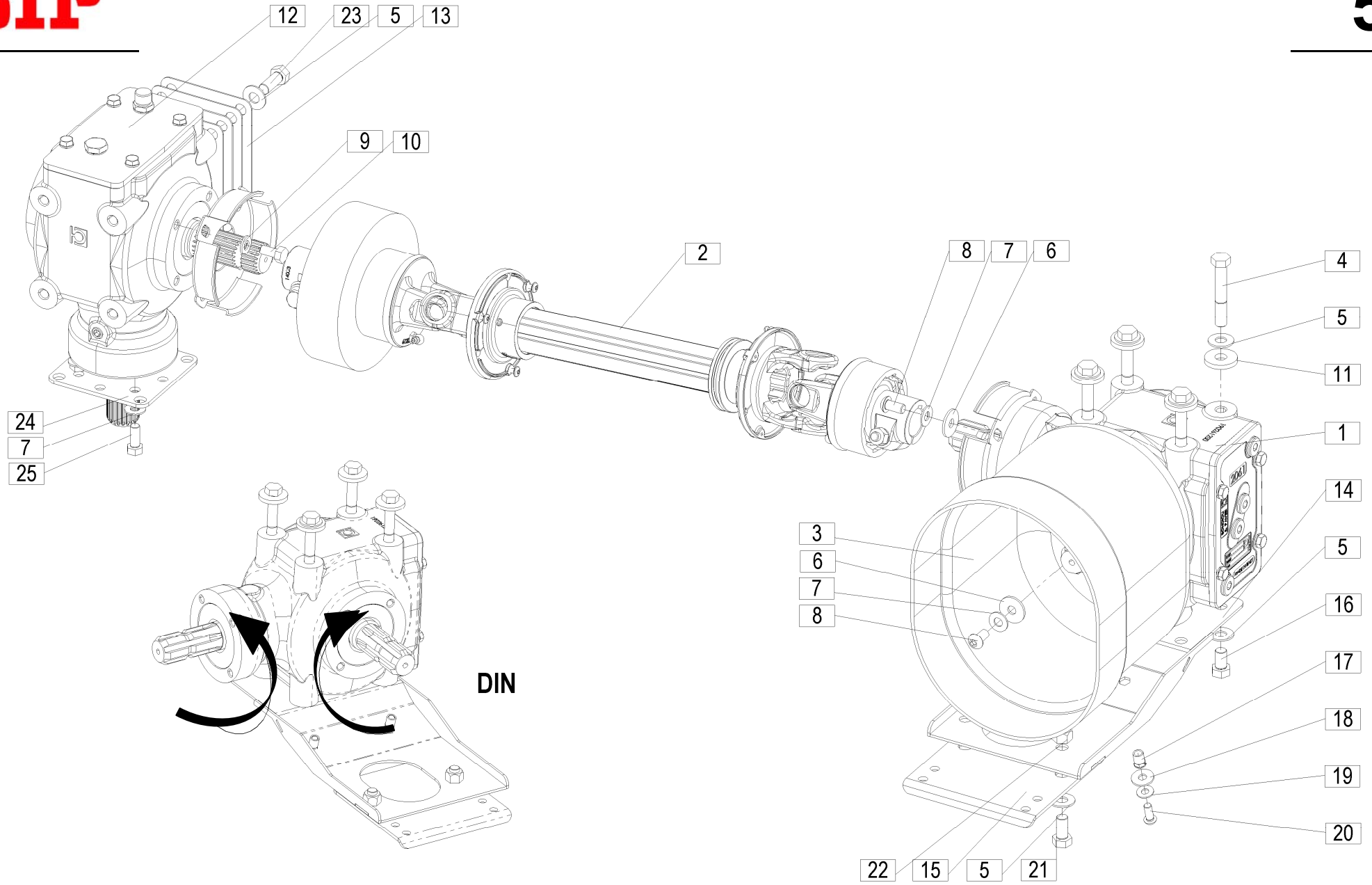

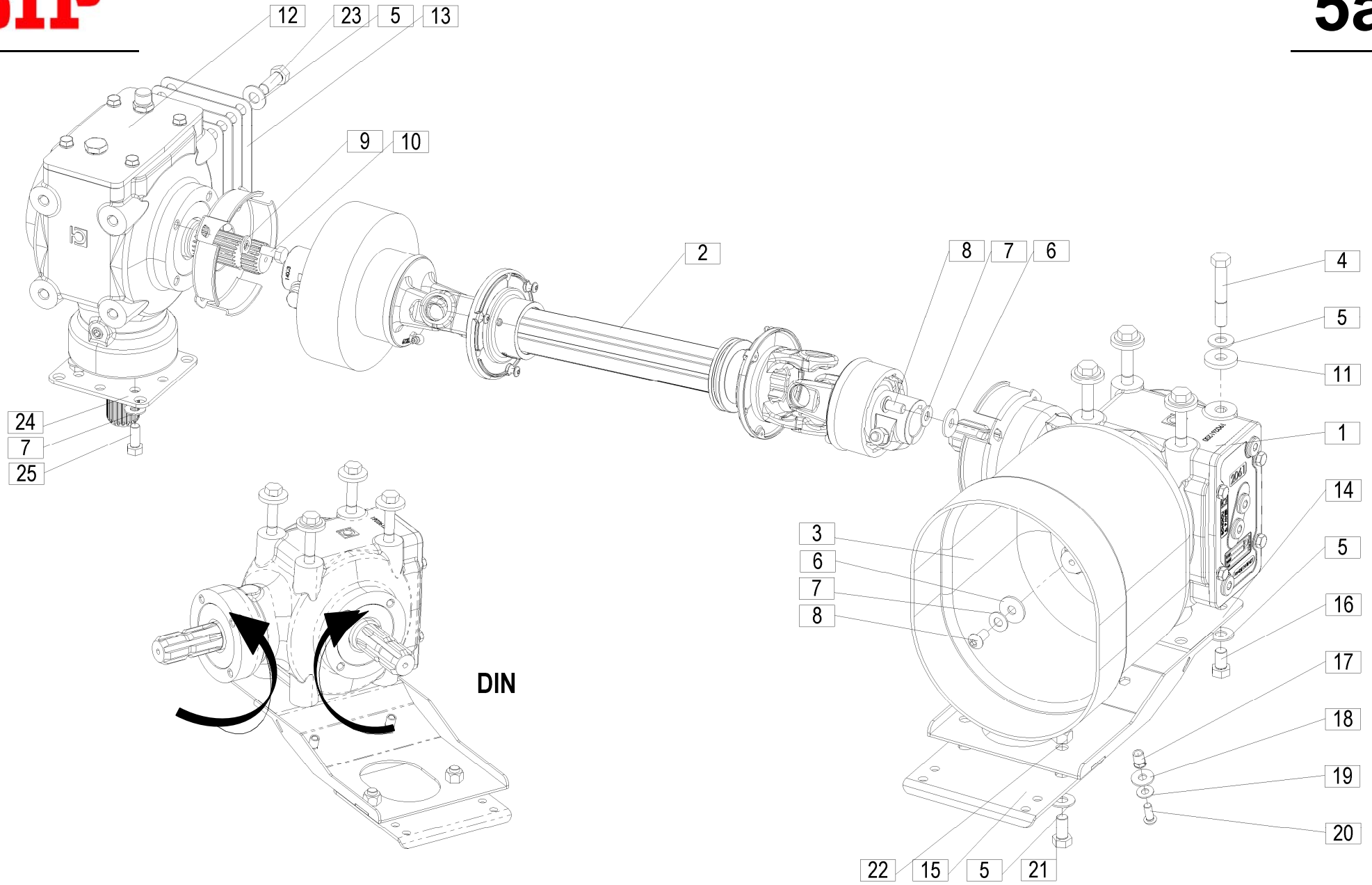

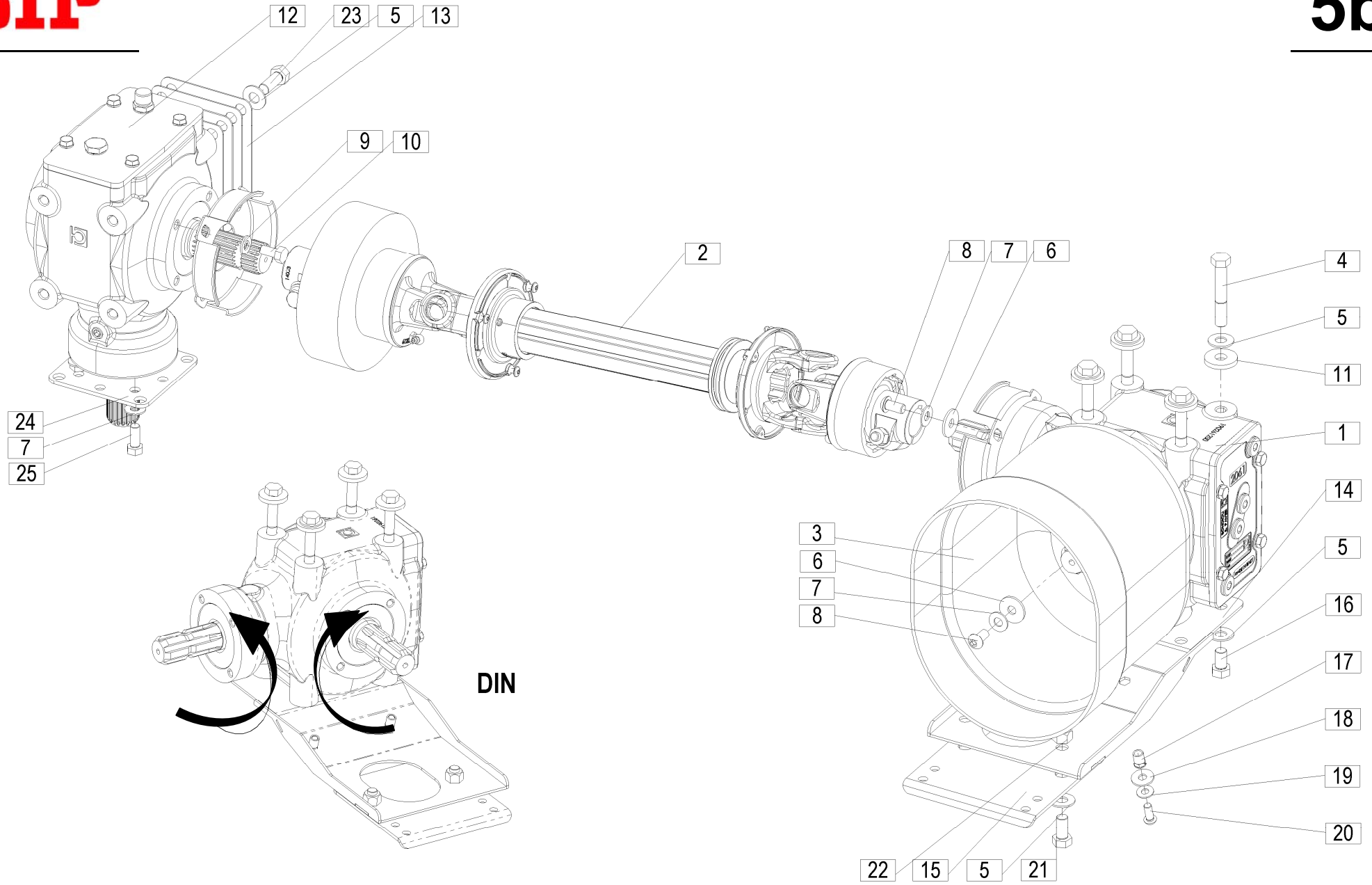

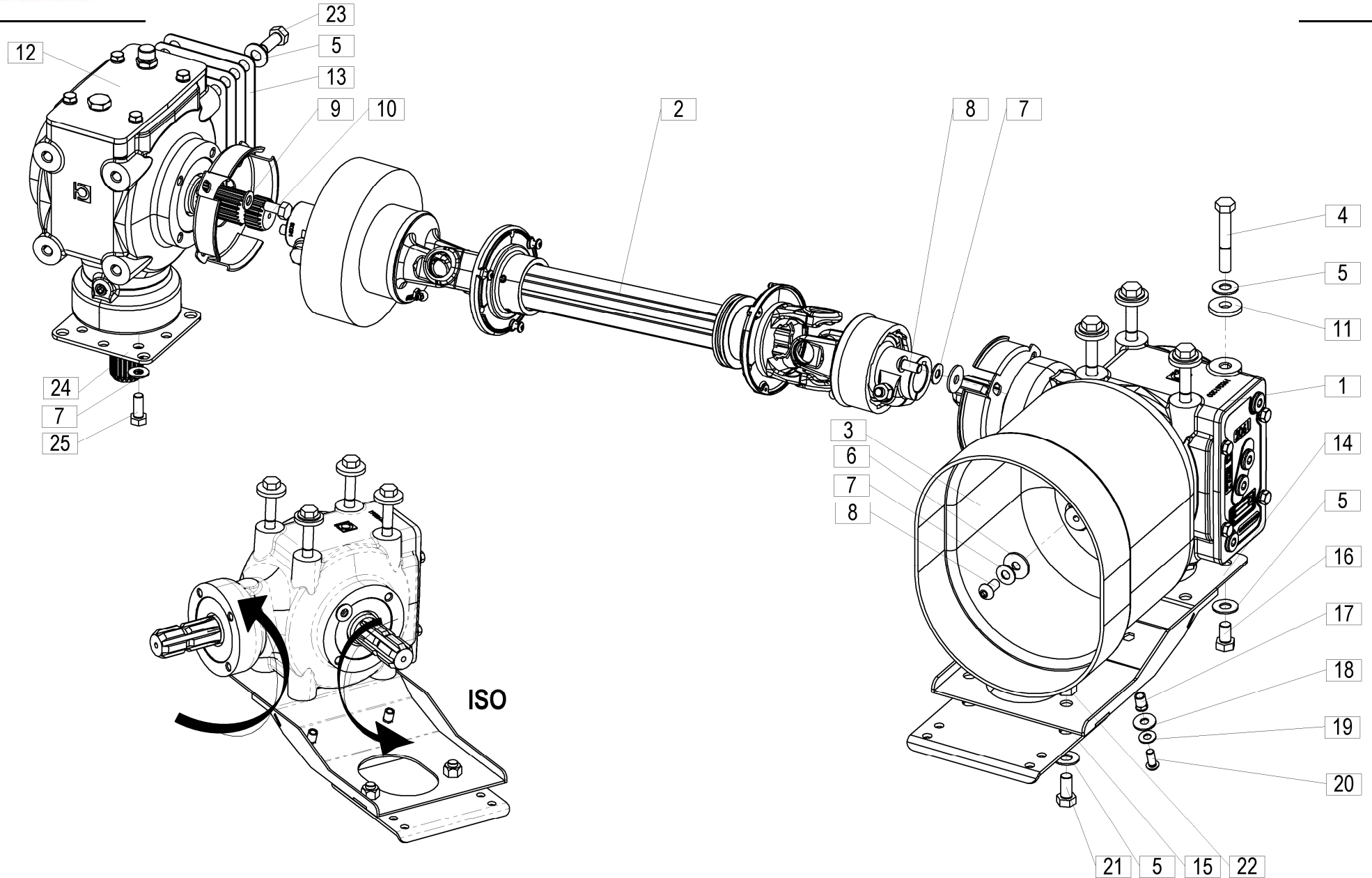

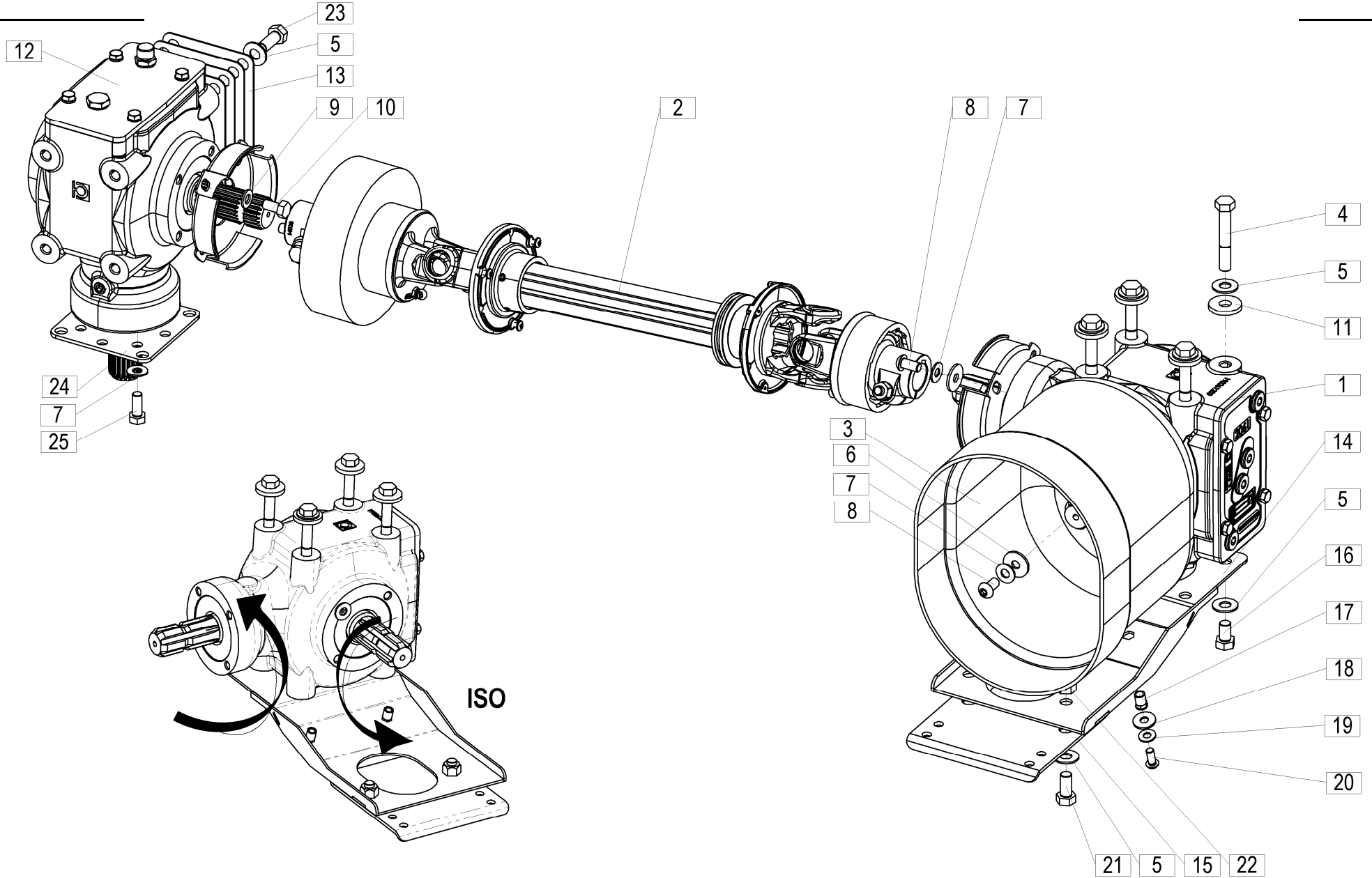

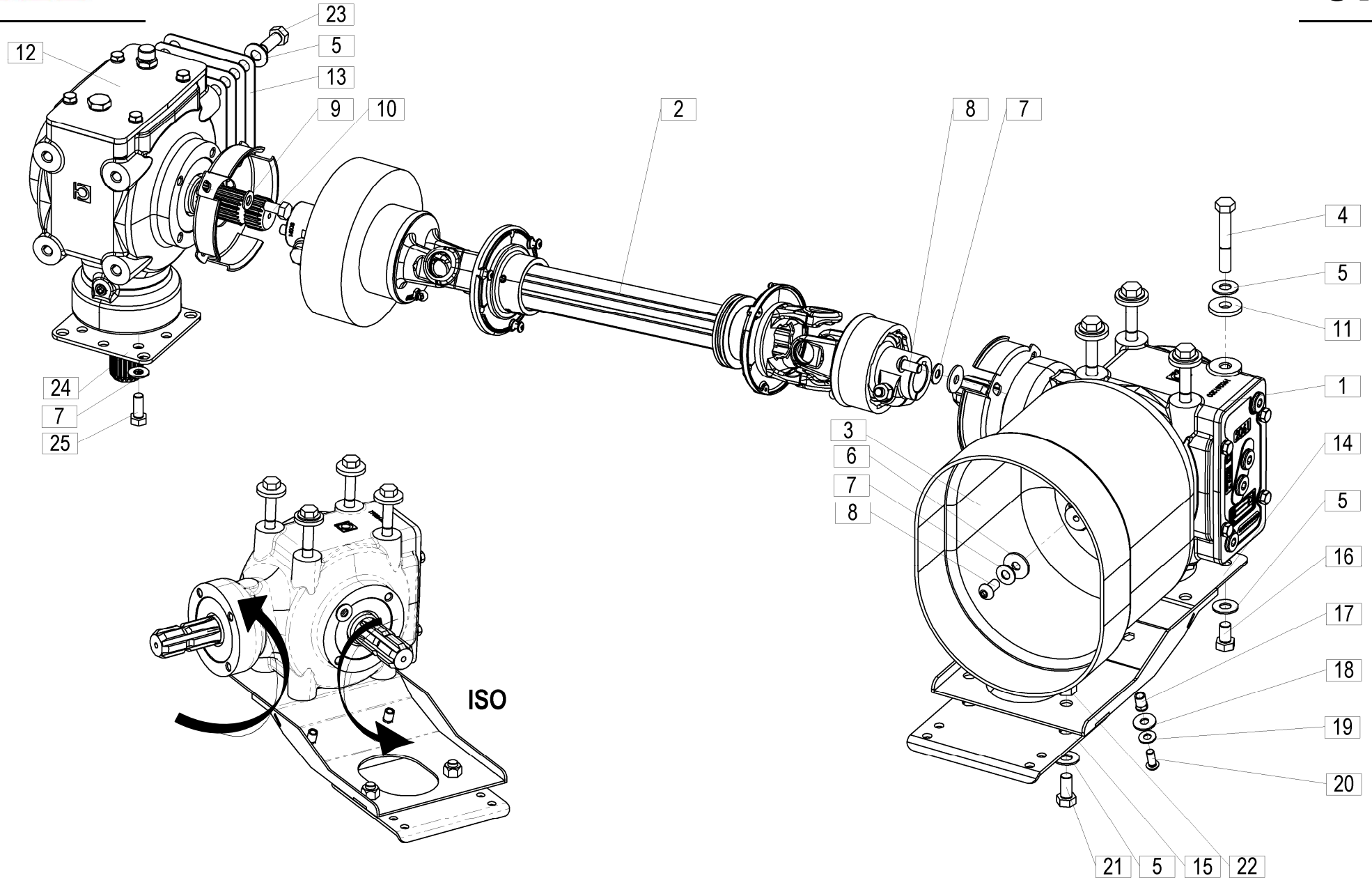

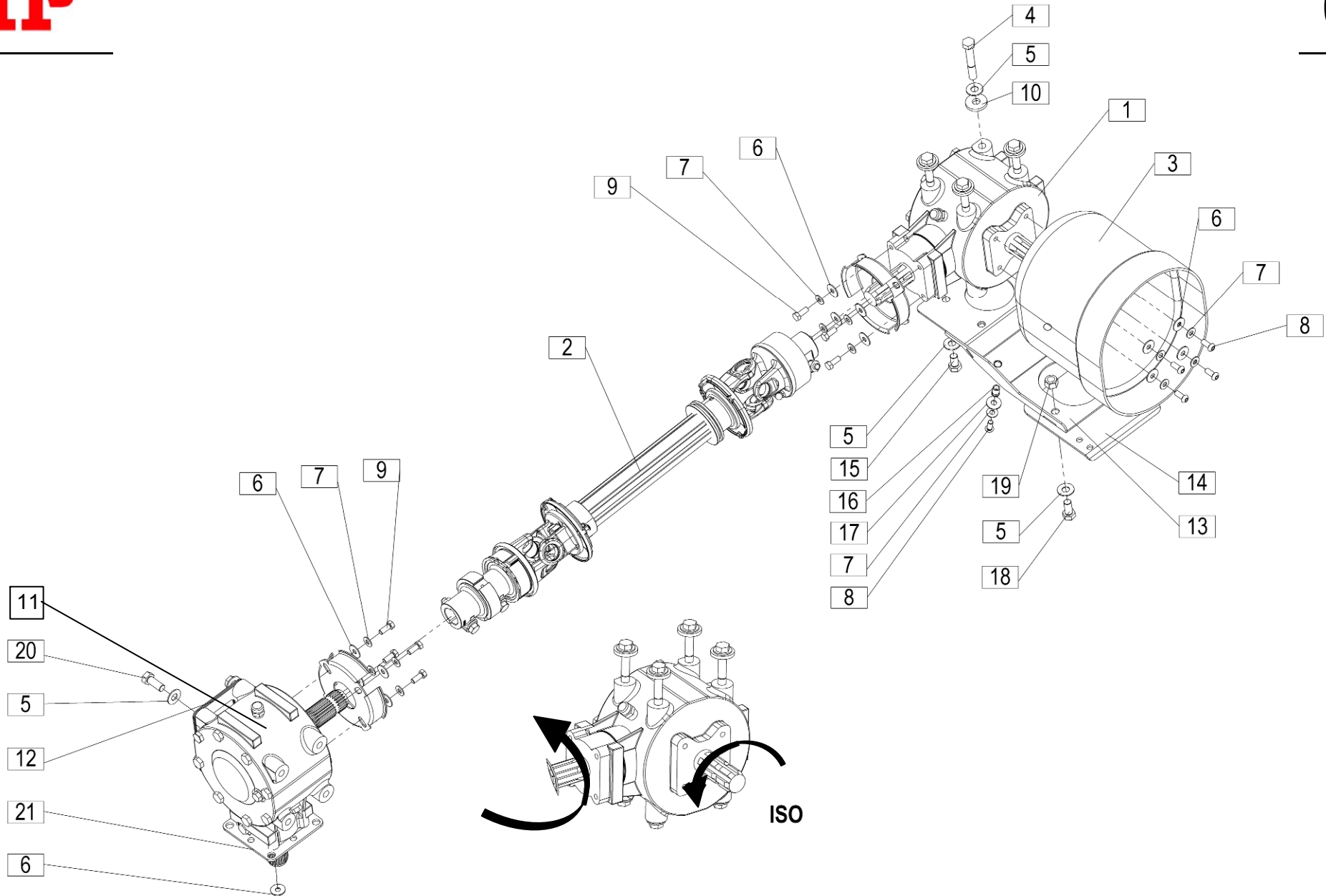

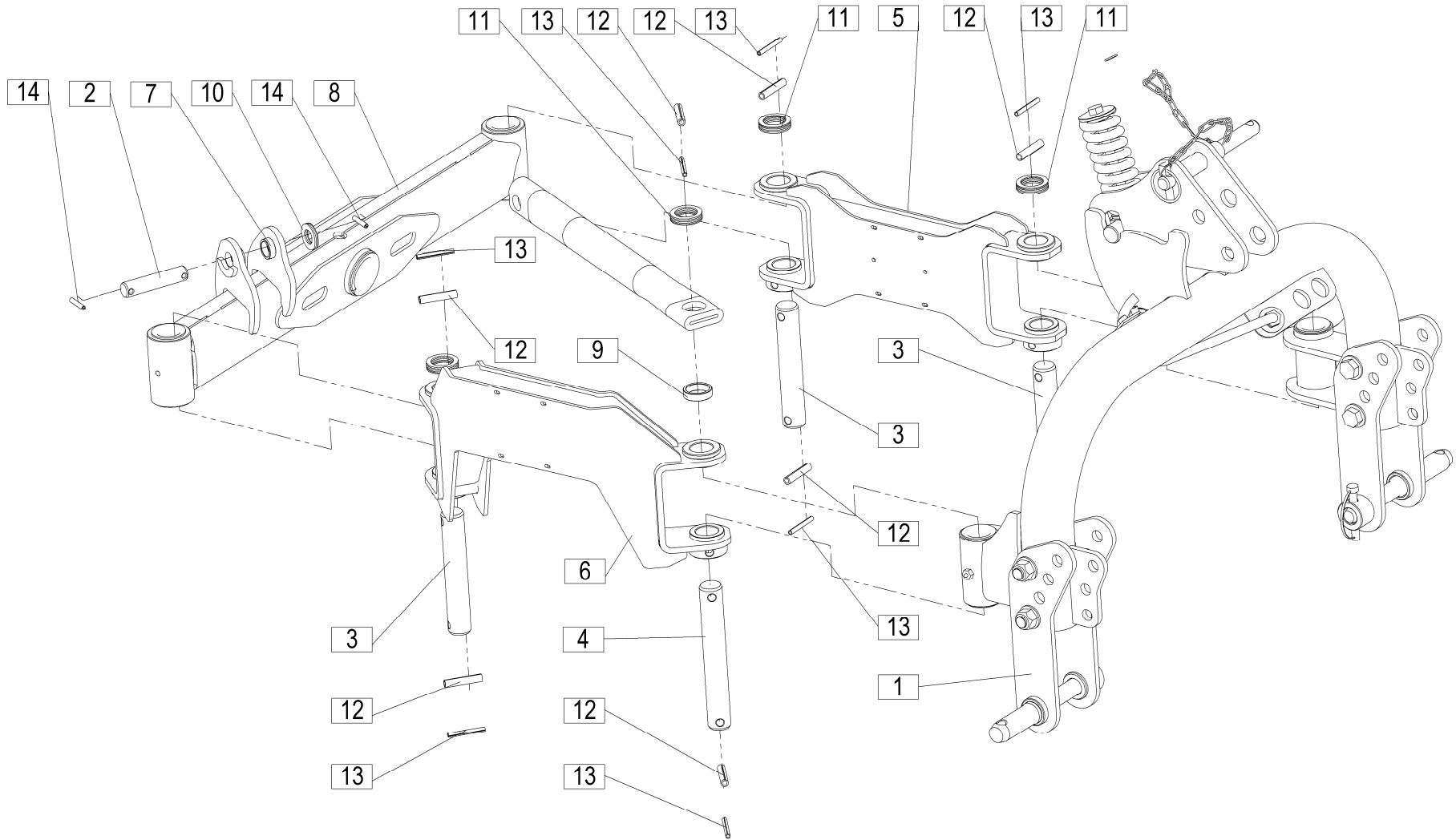

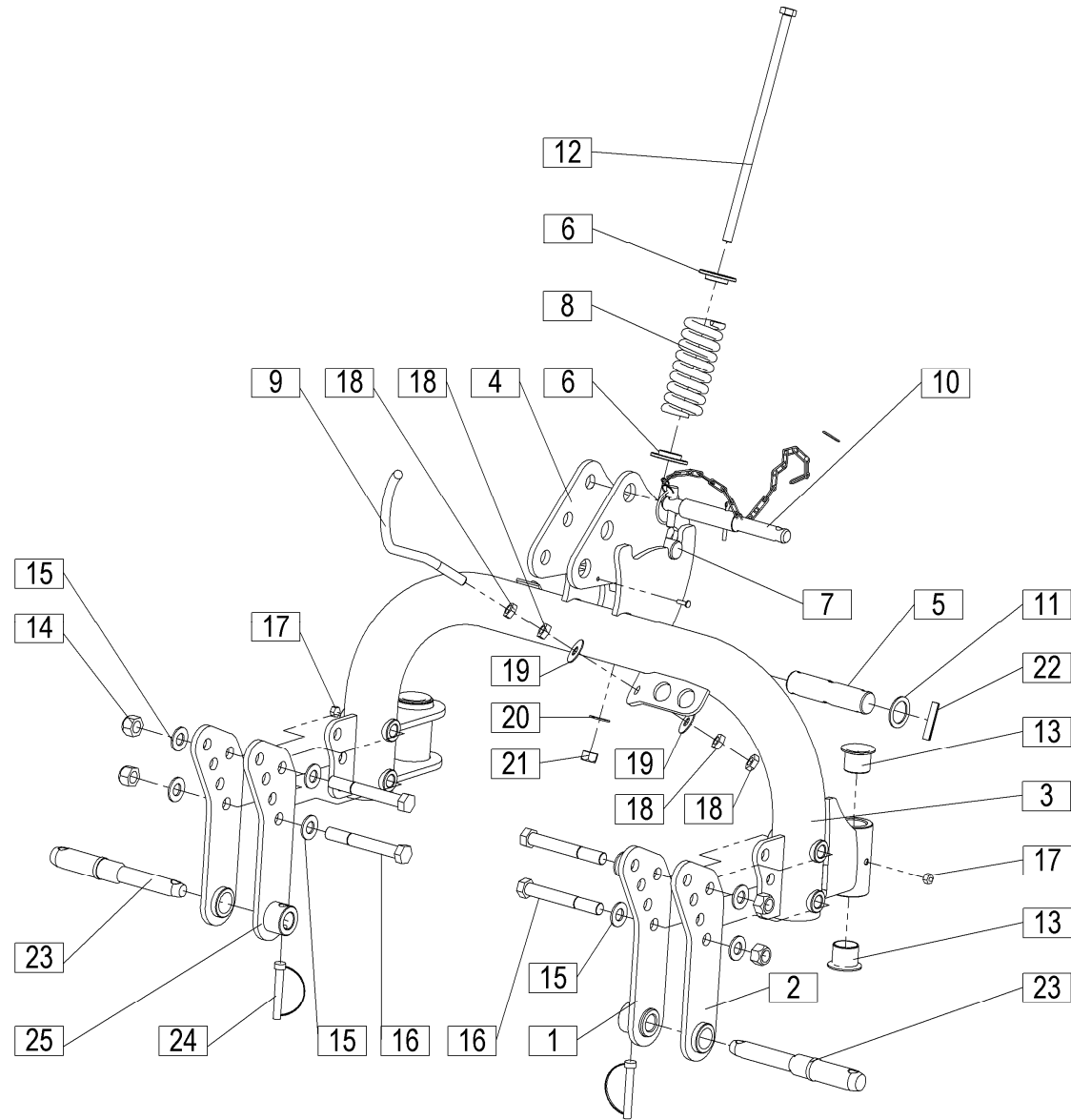

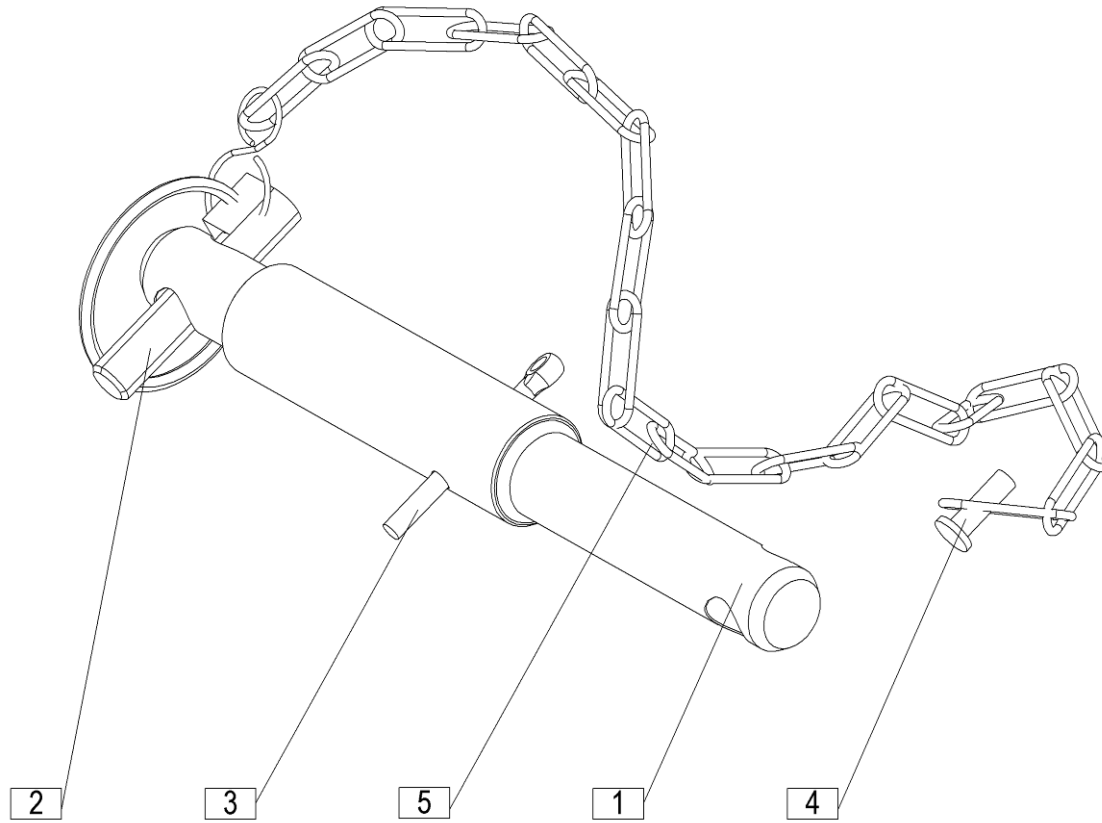

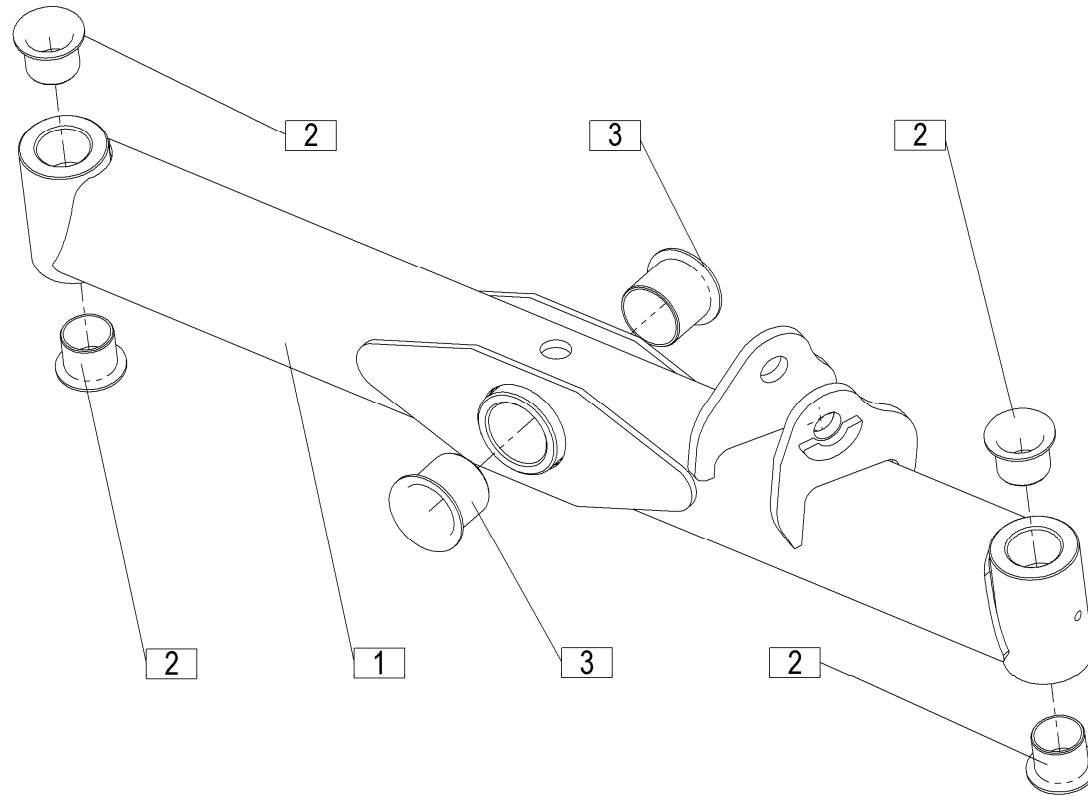

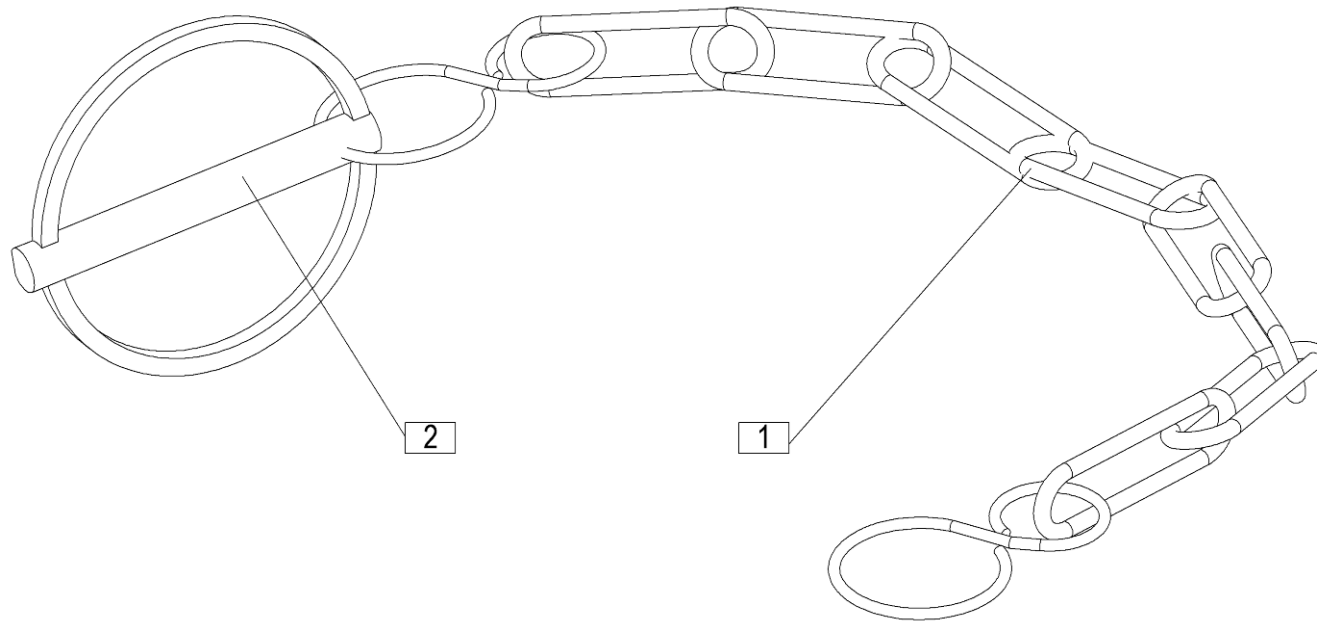

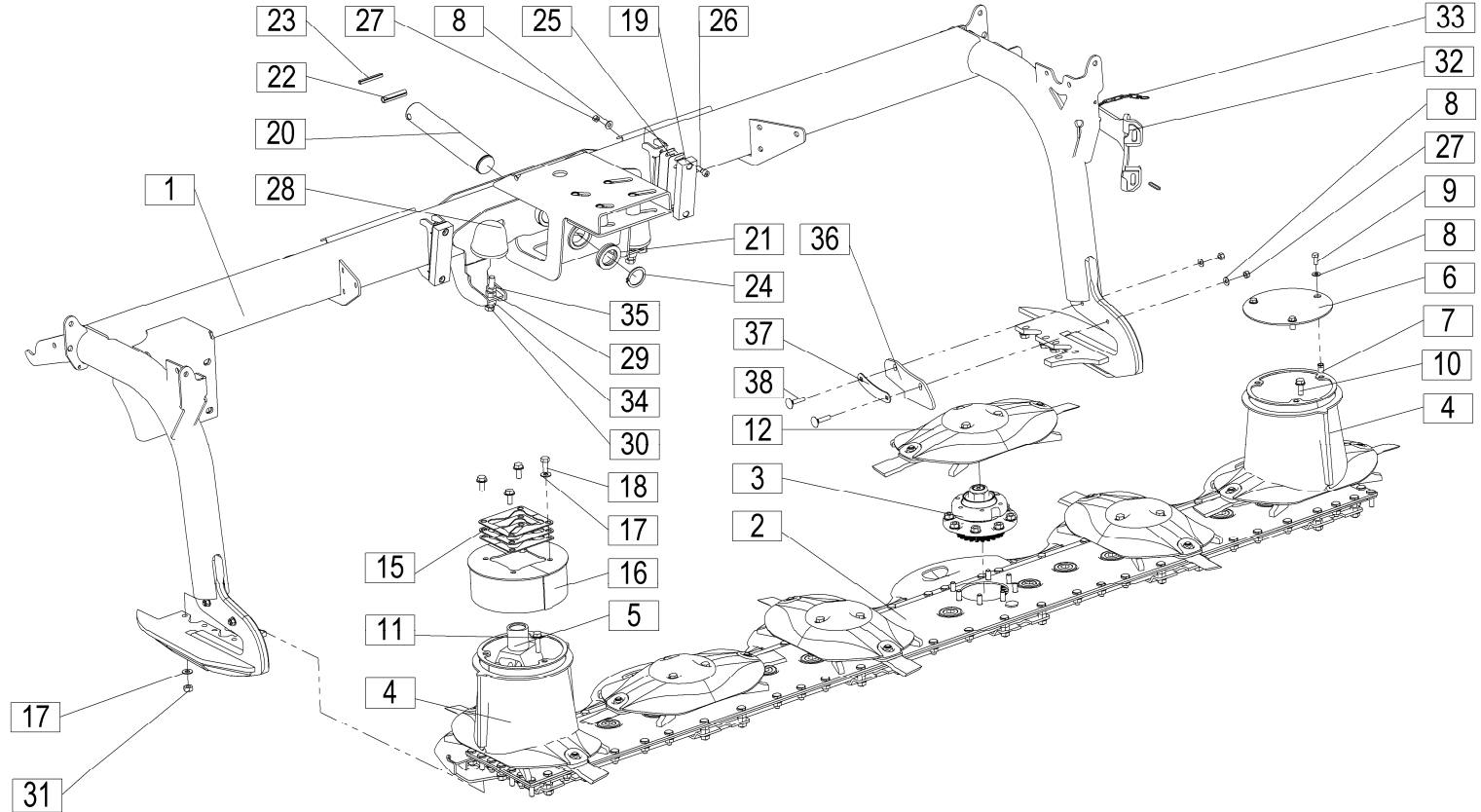
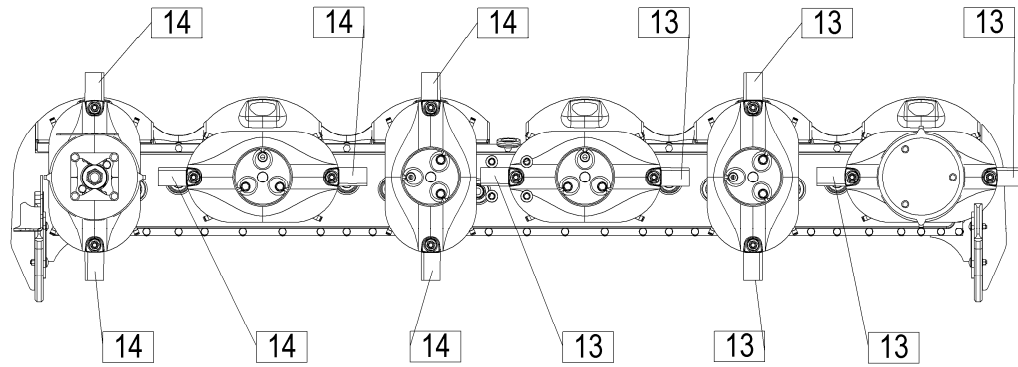

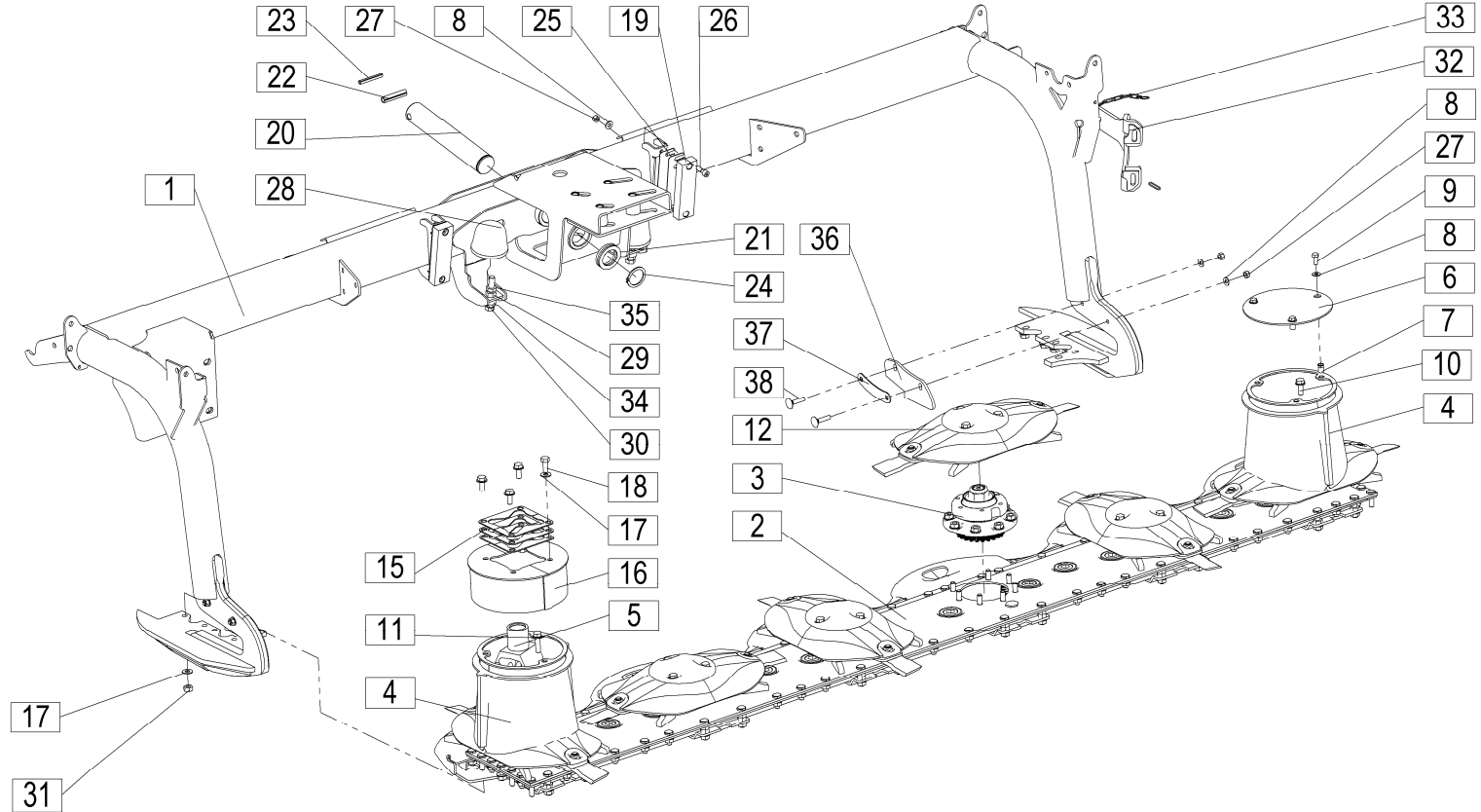
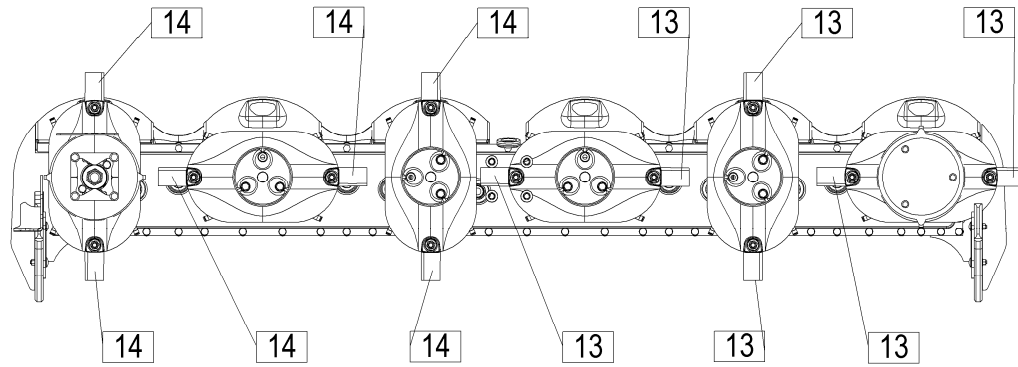

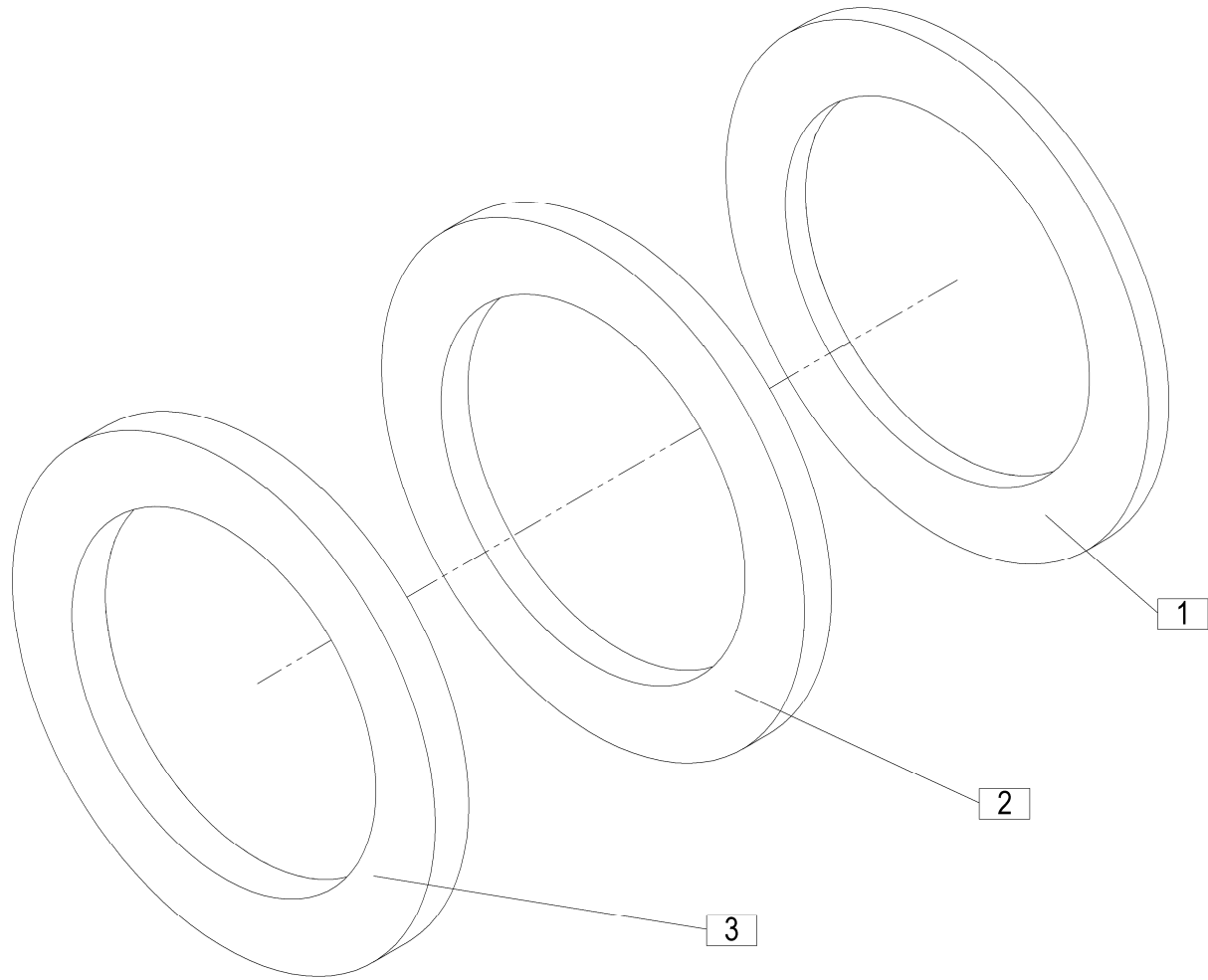

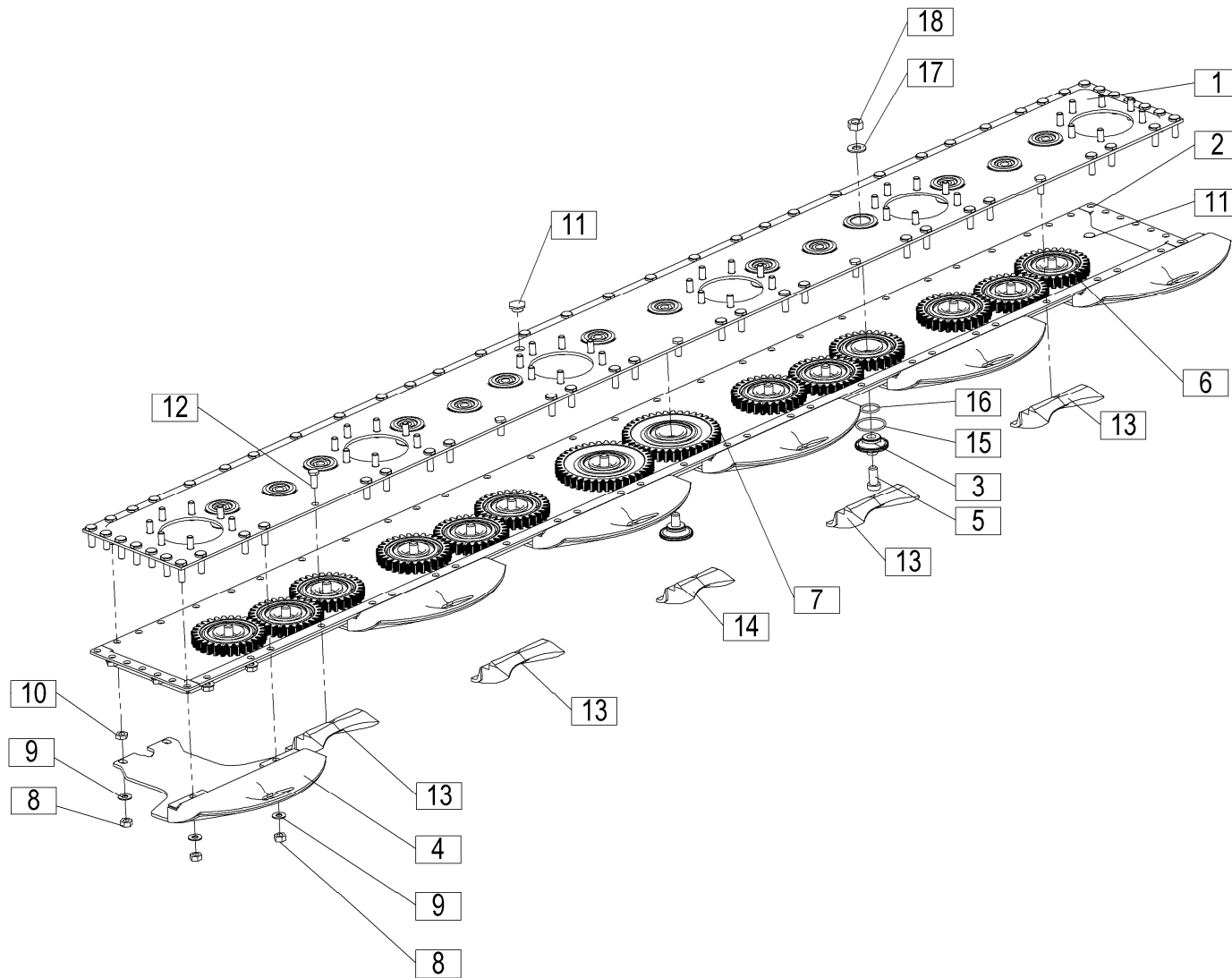

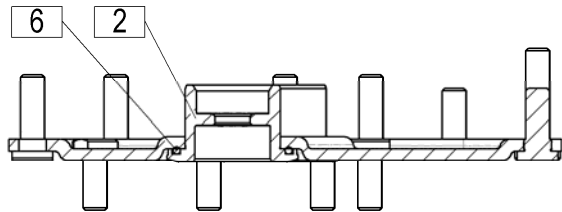
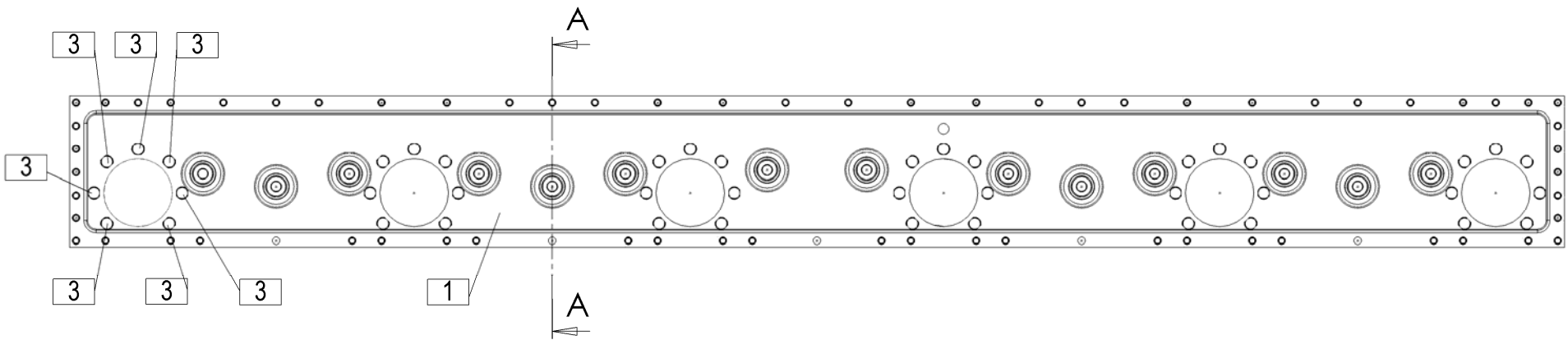
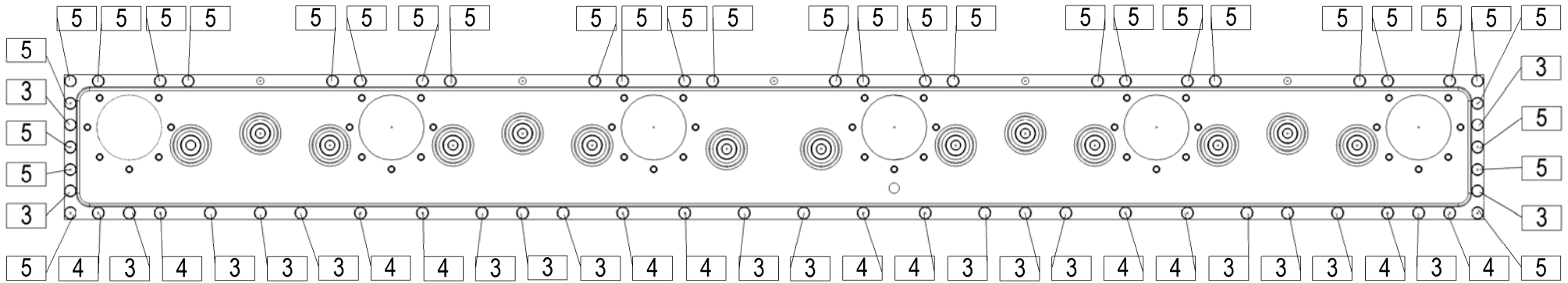

SECTION A-A
SCALE 1 : 2

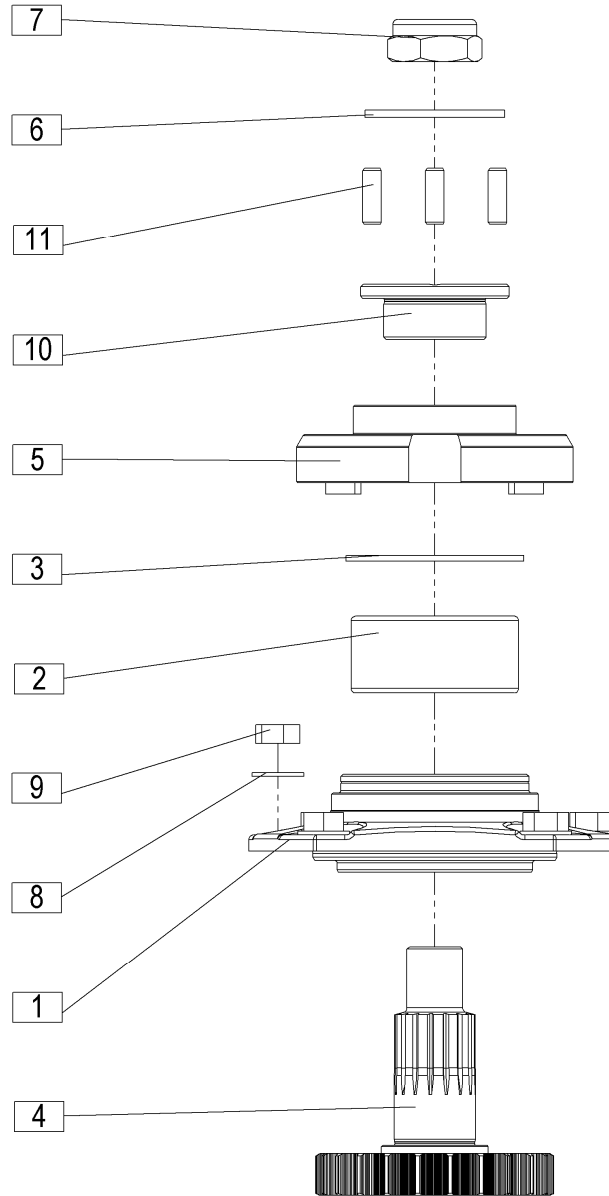

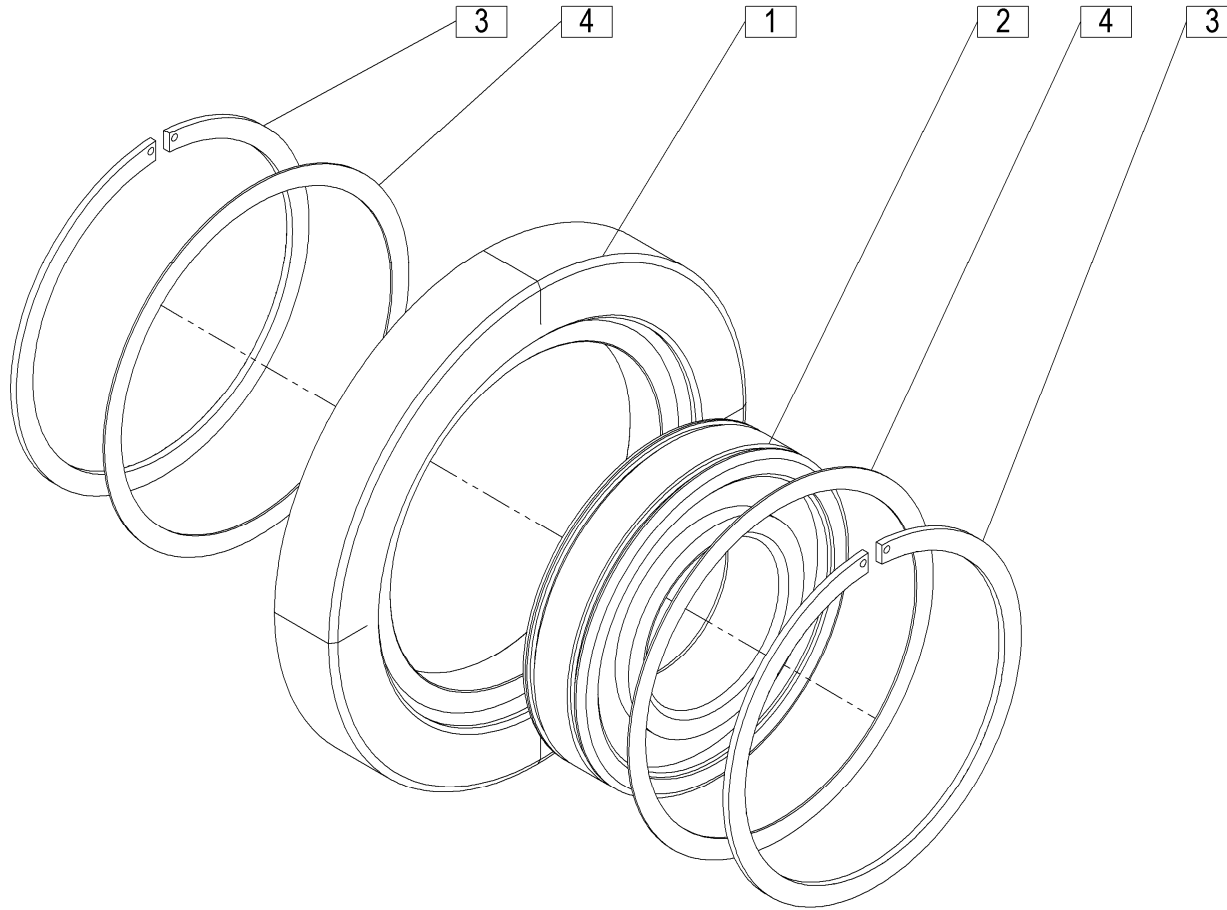

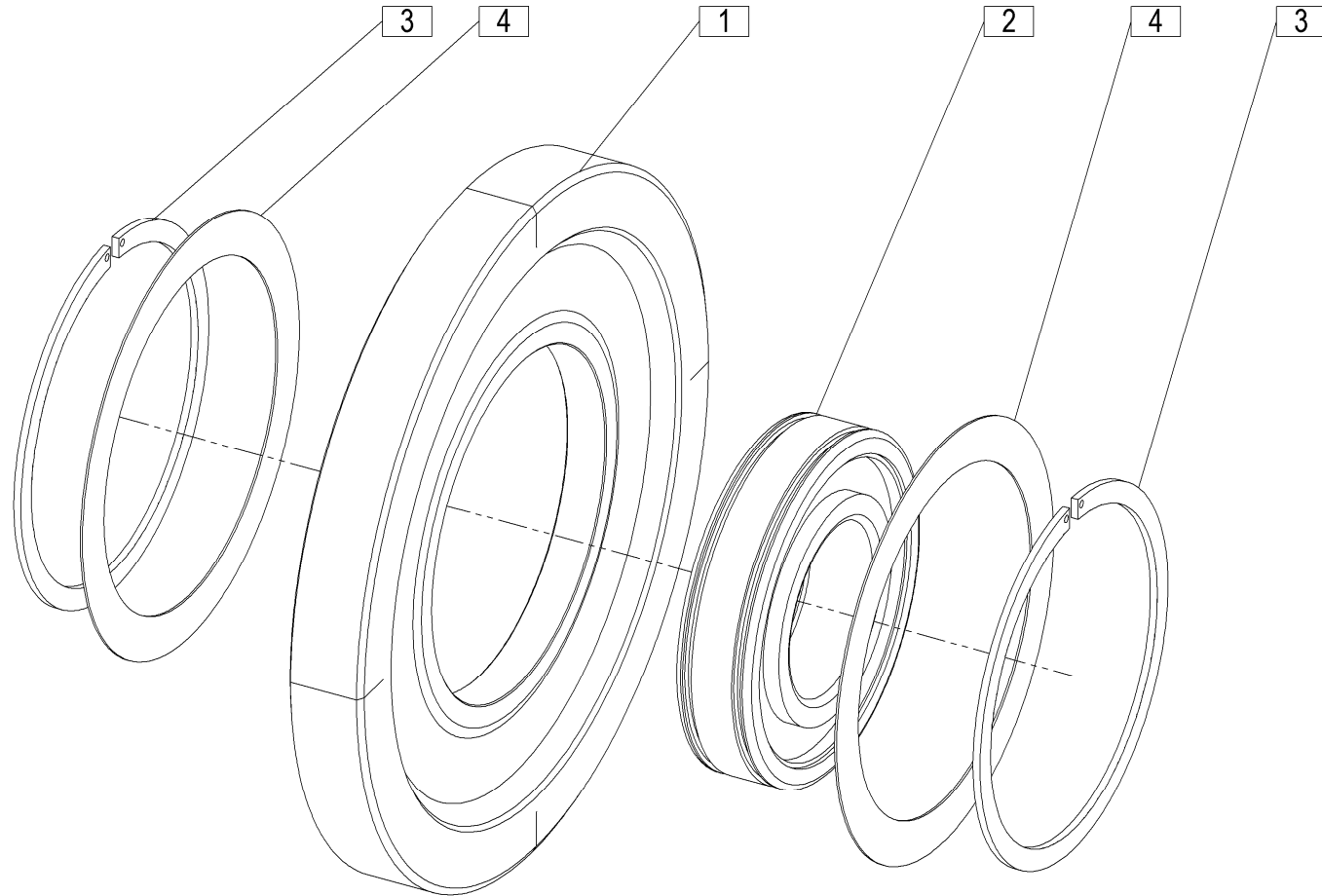

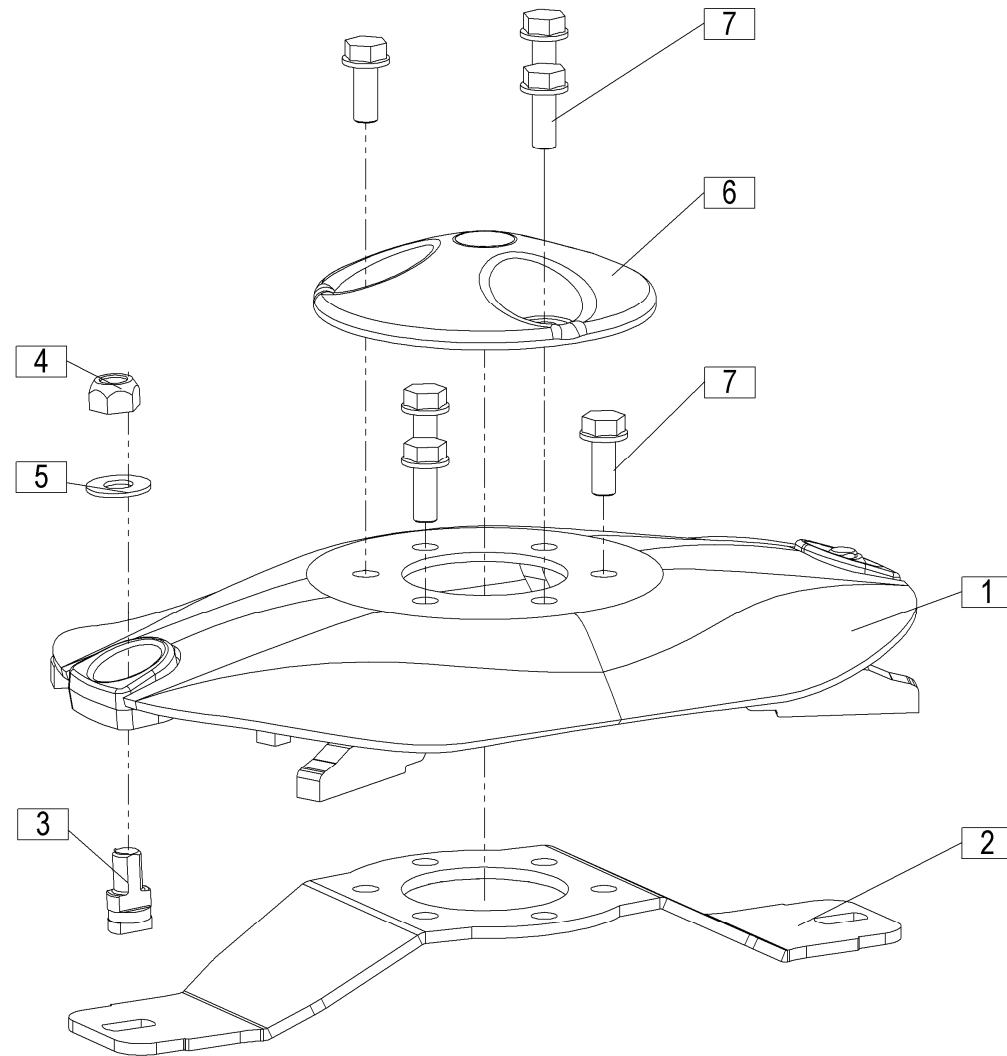

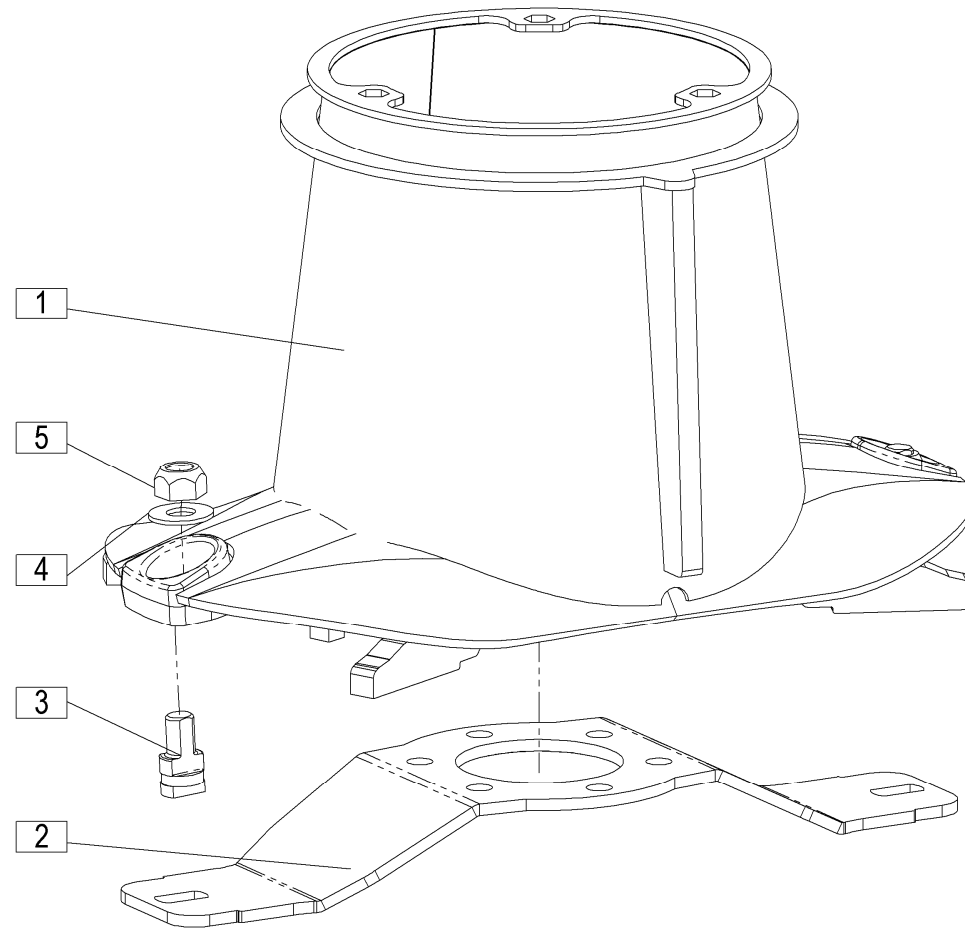

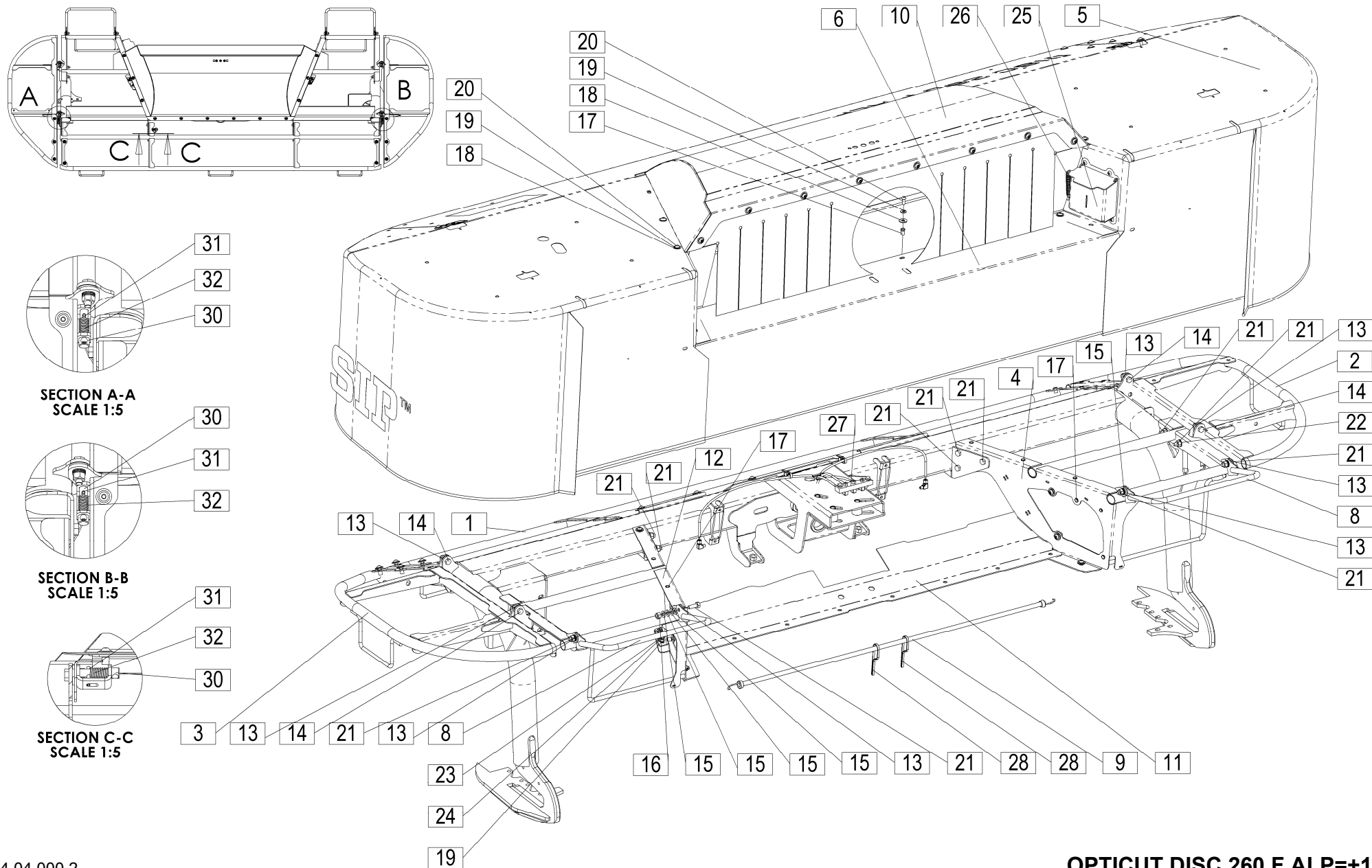

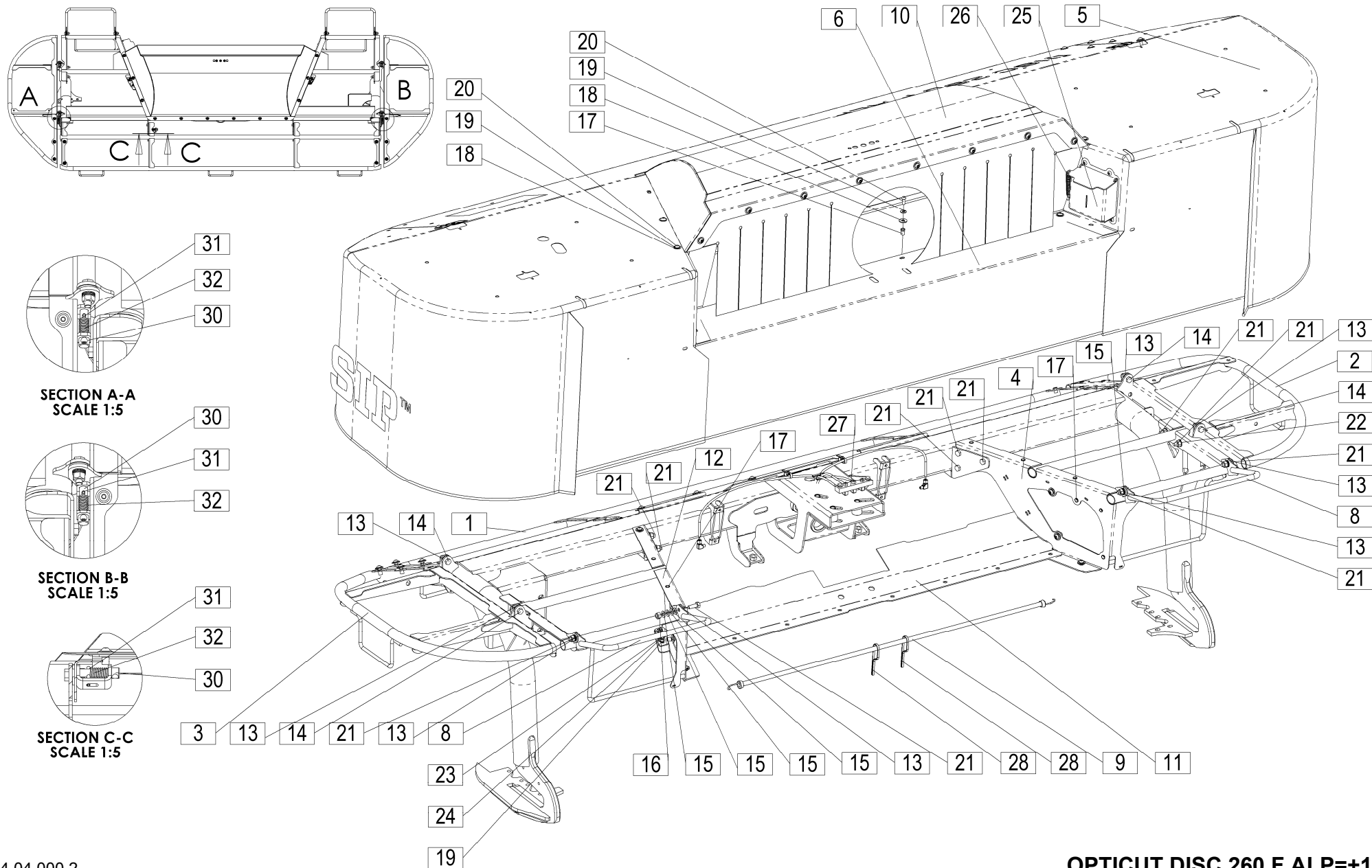

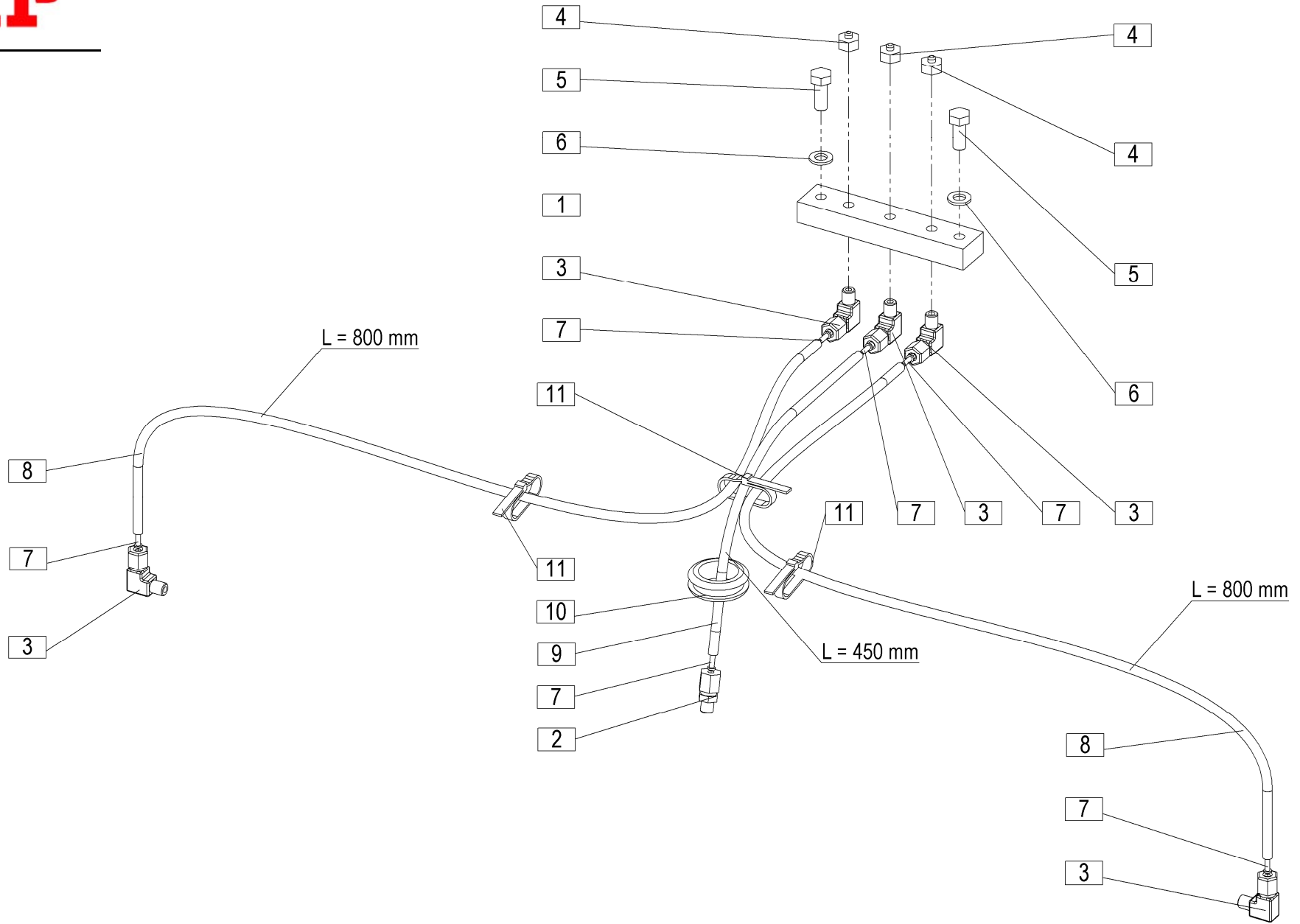

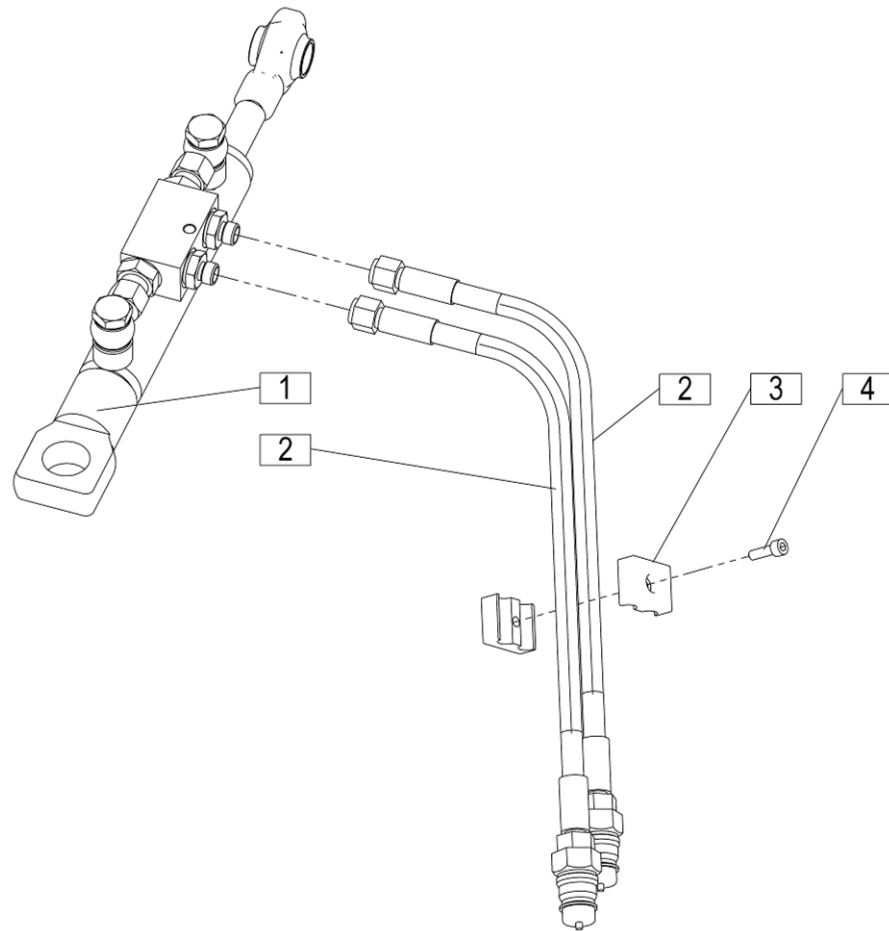

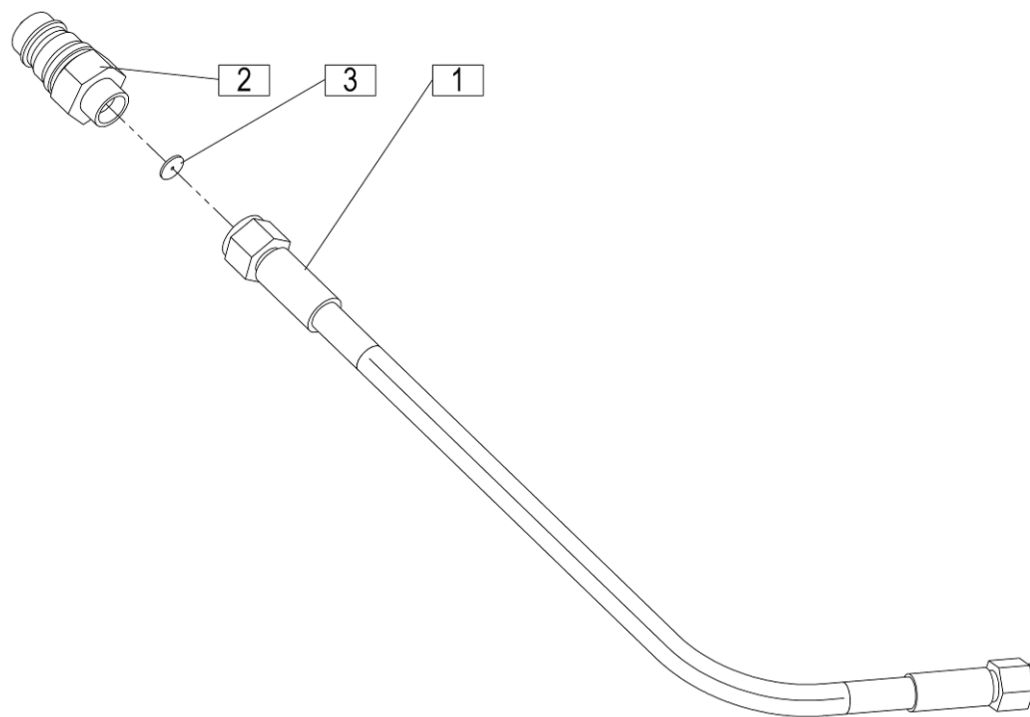

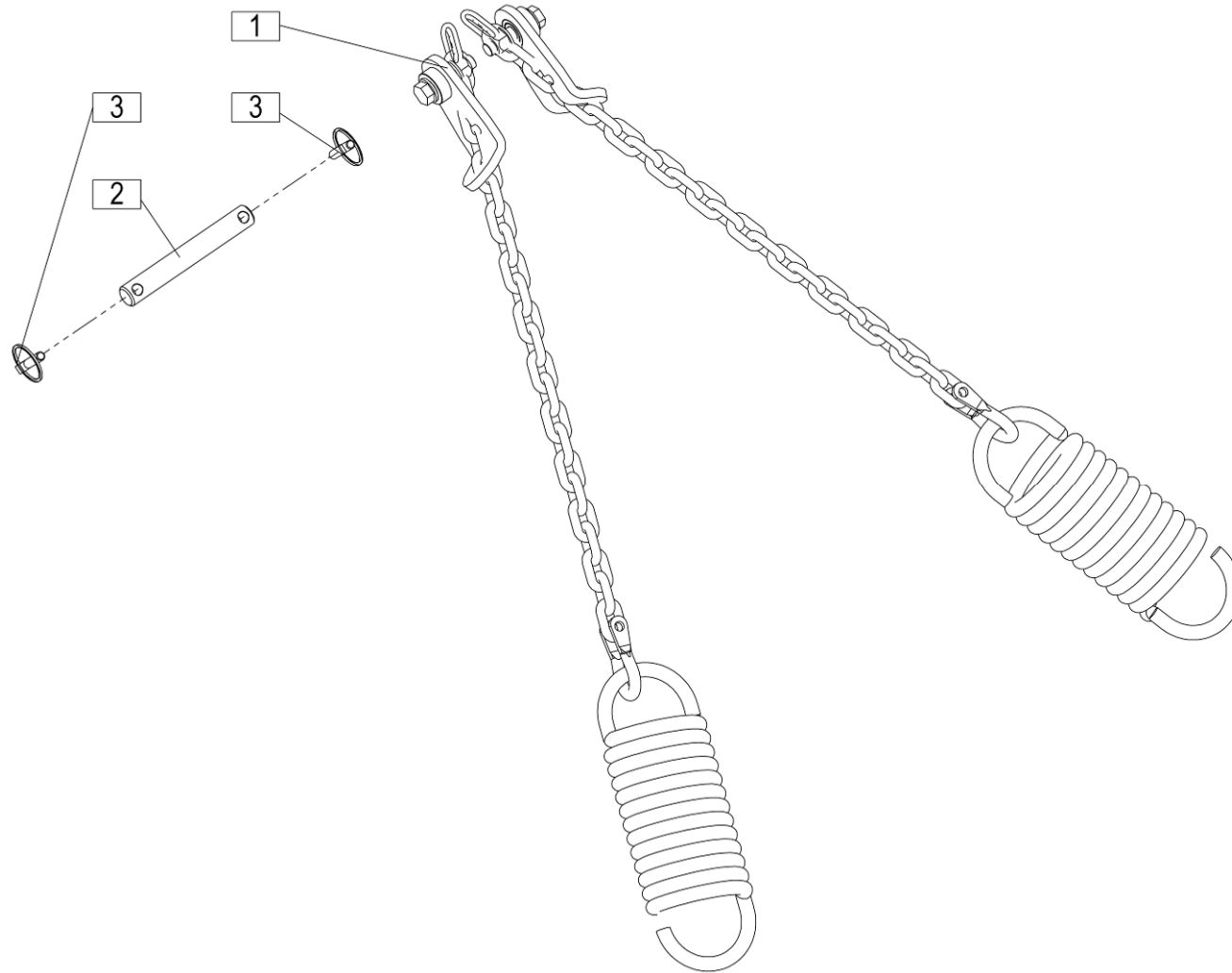

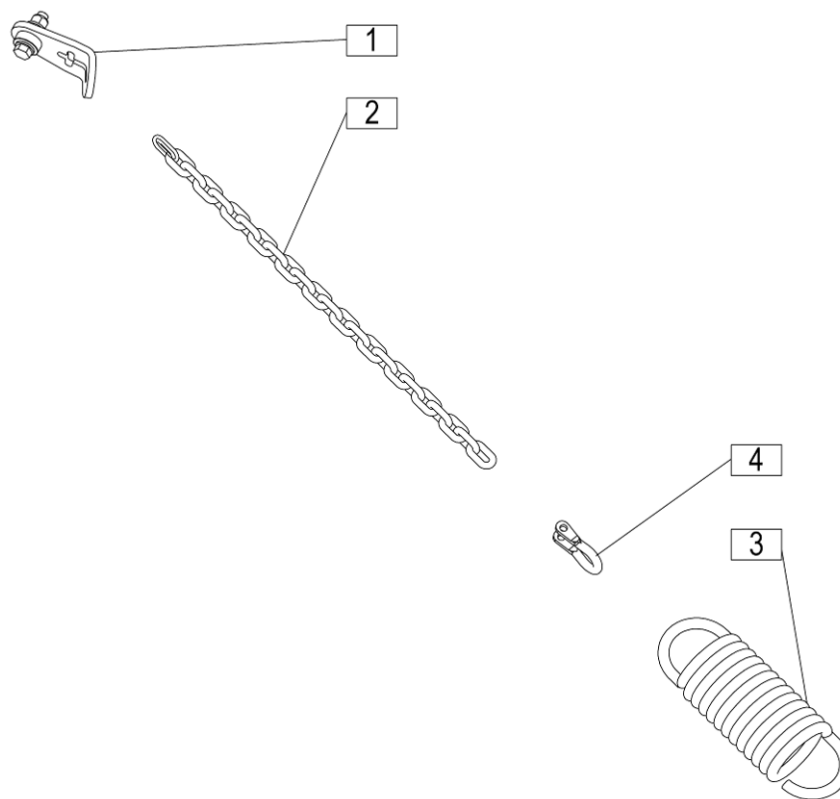

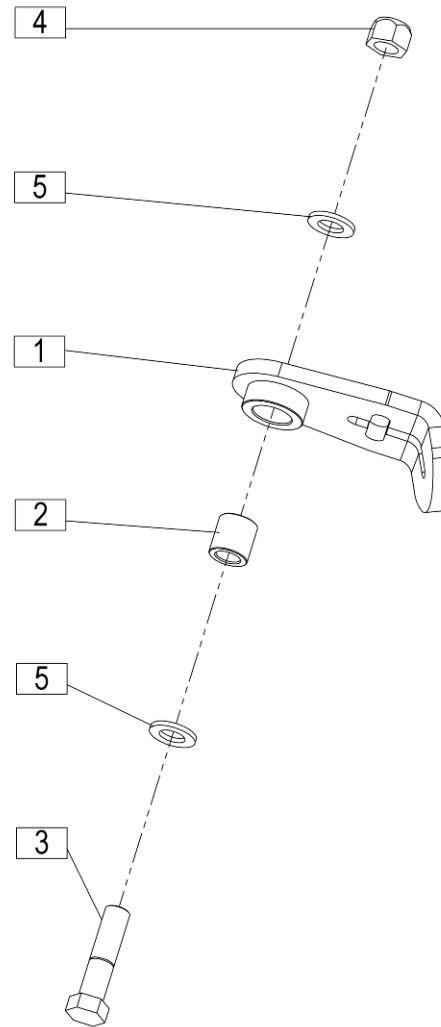

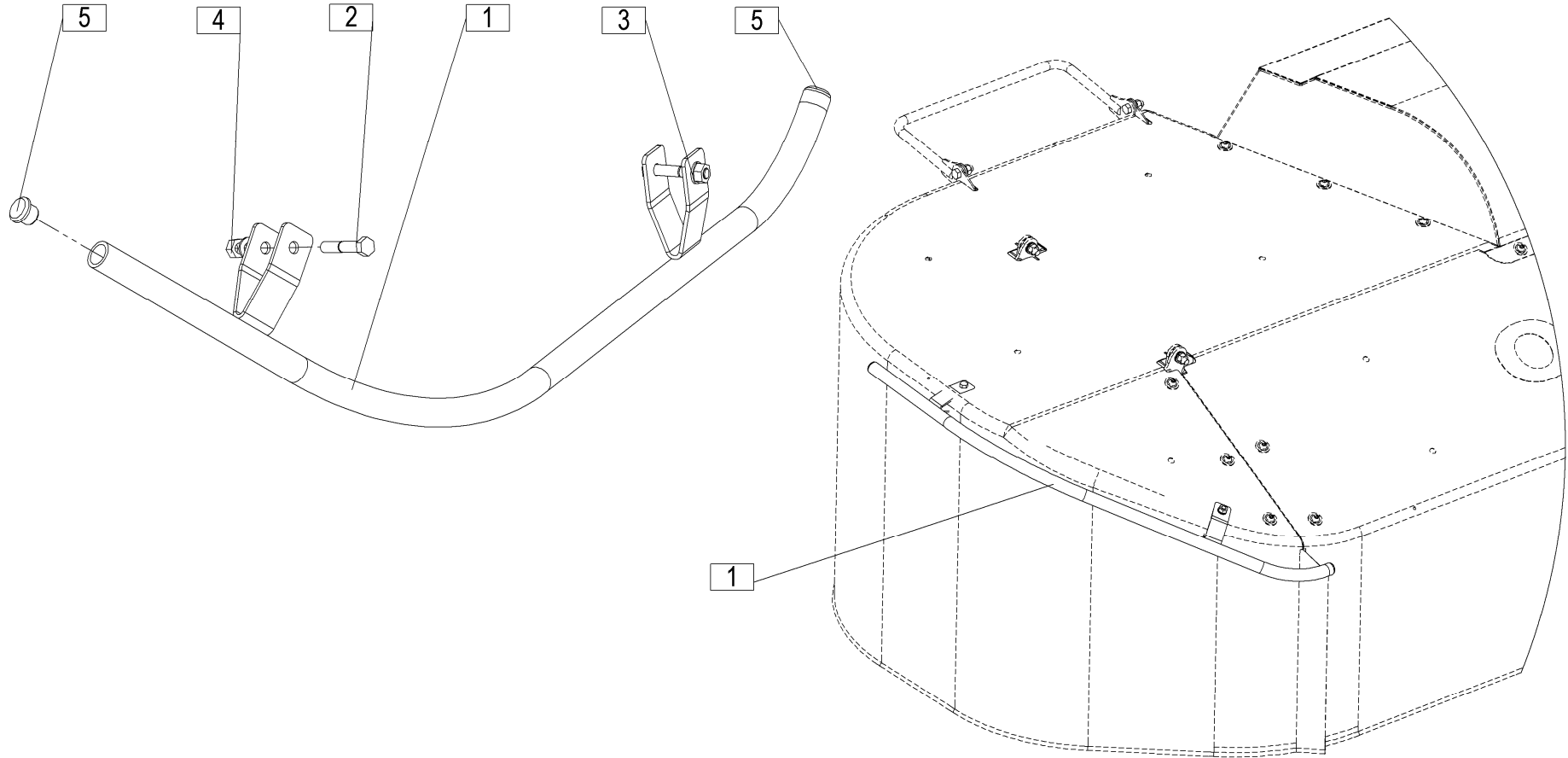

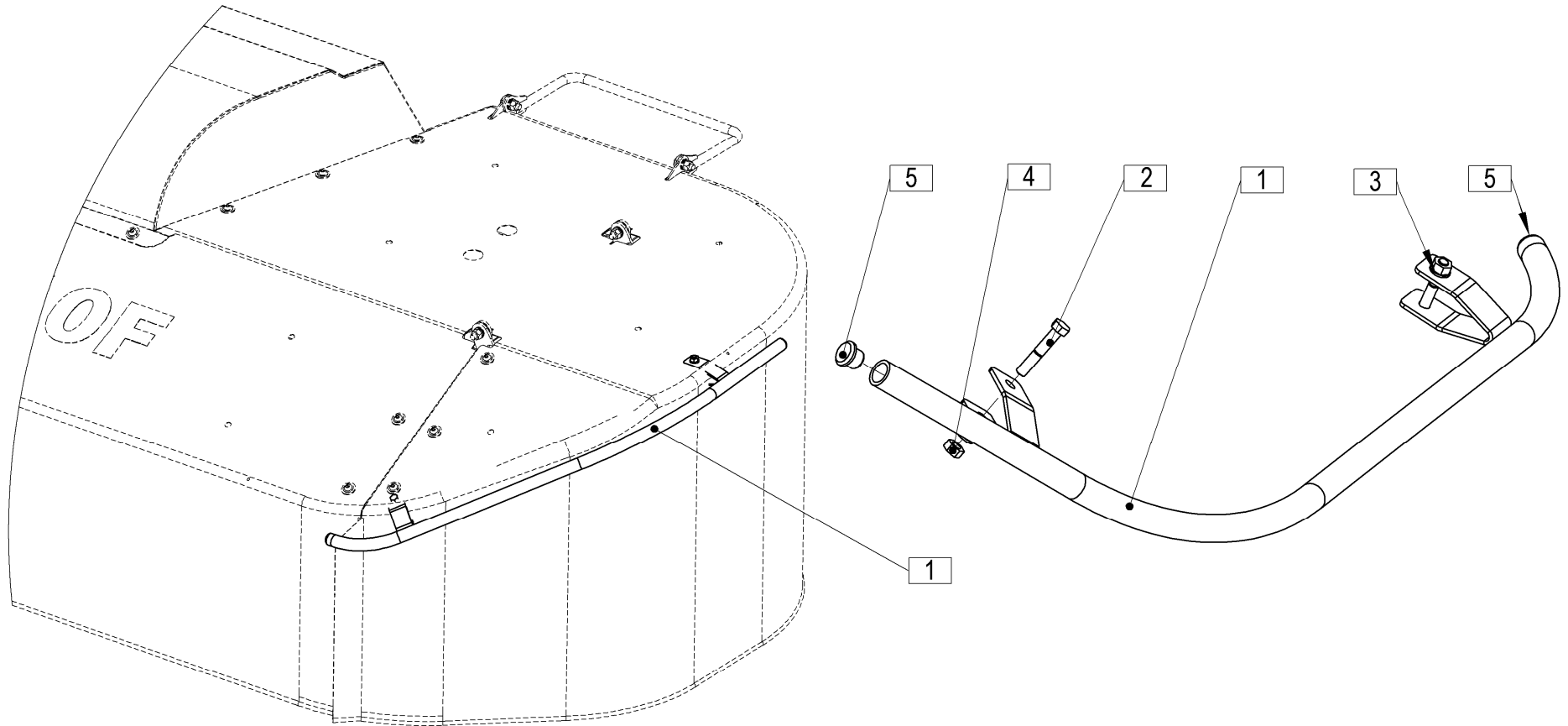

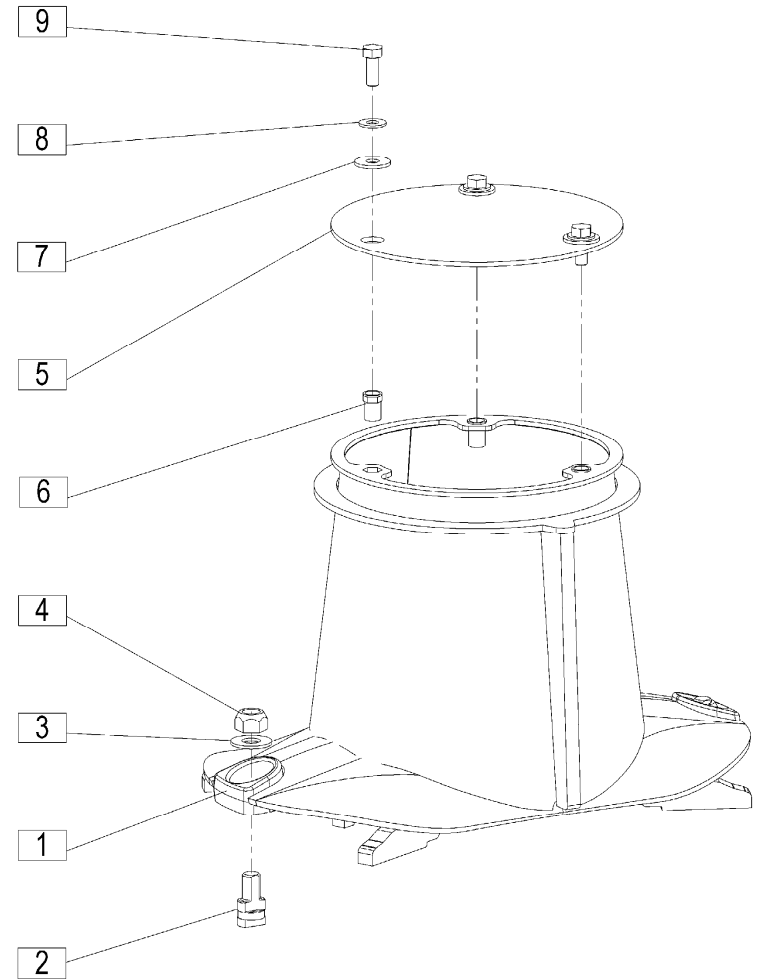
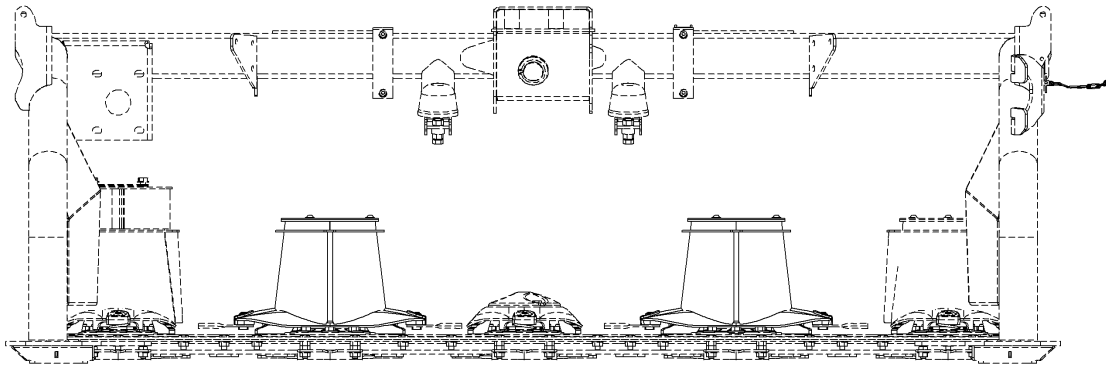

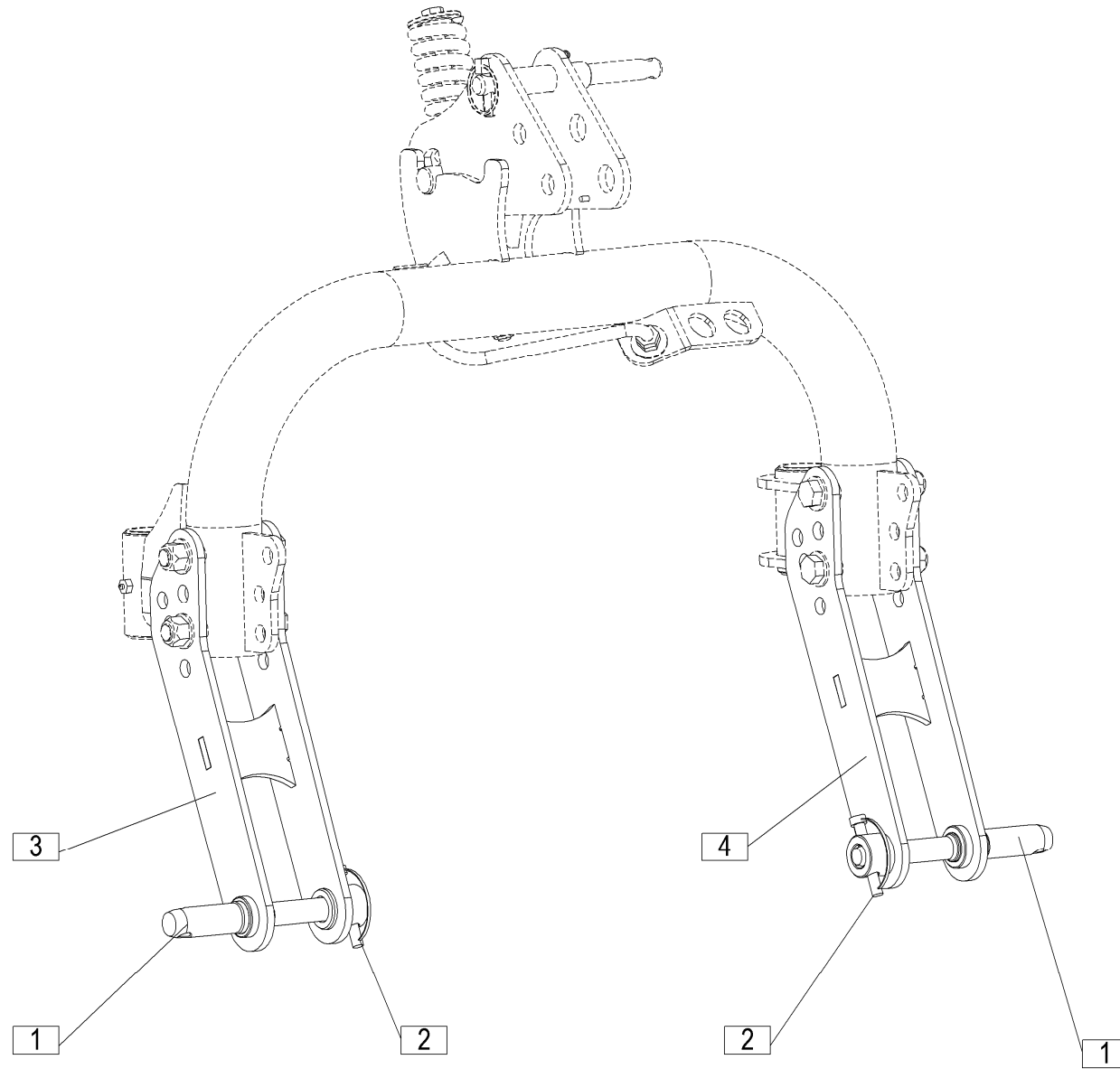

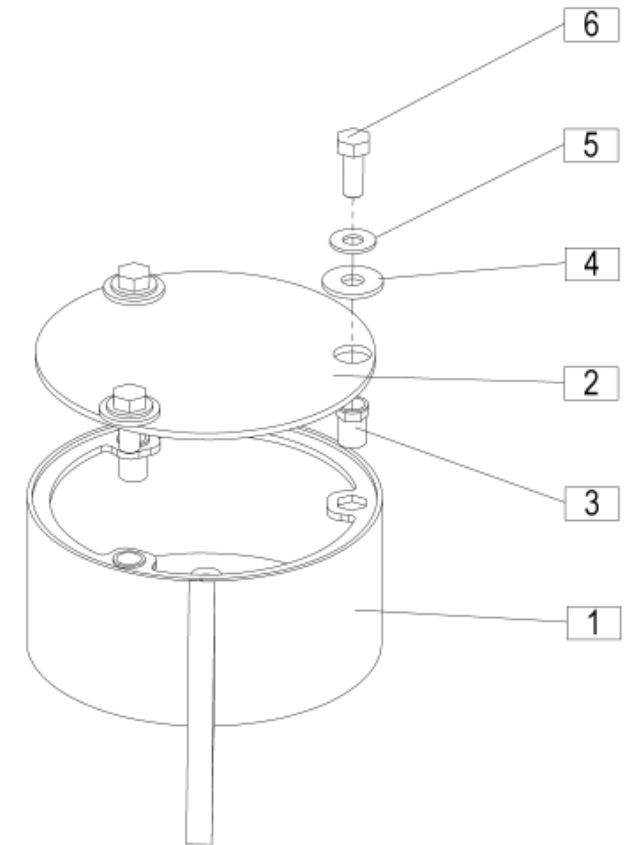
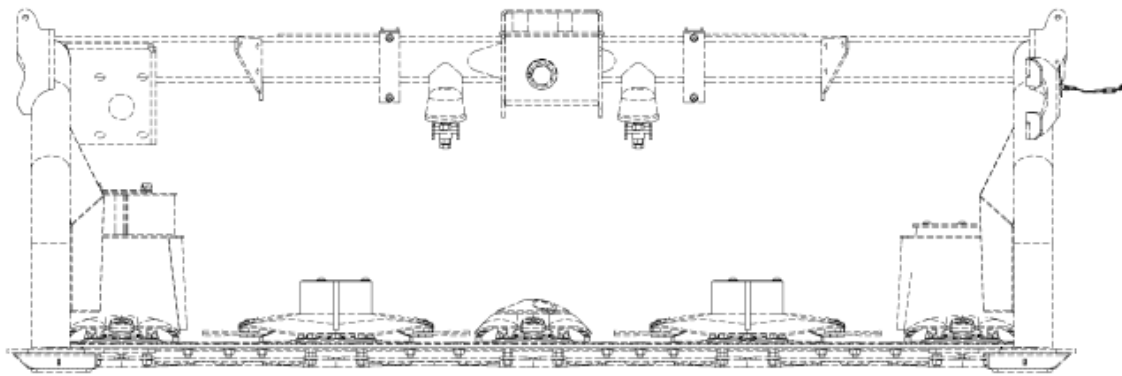

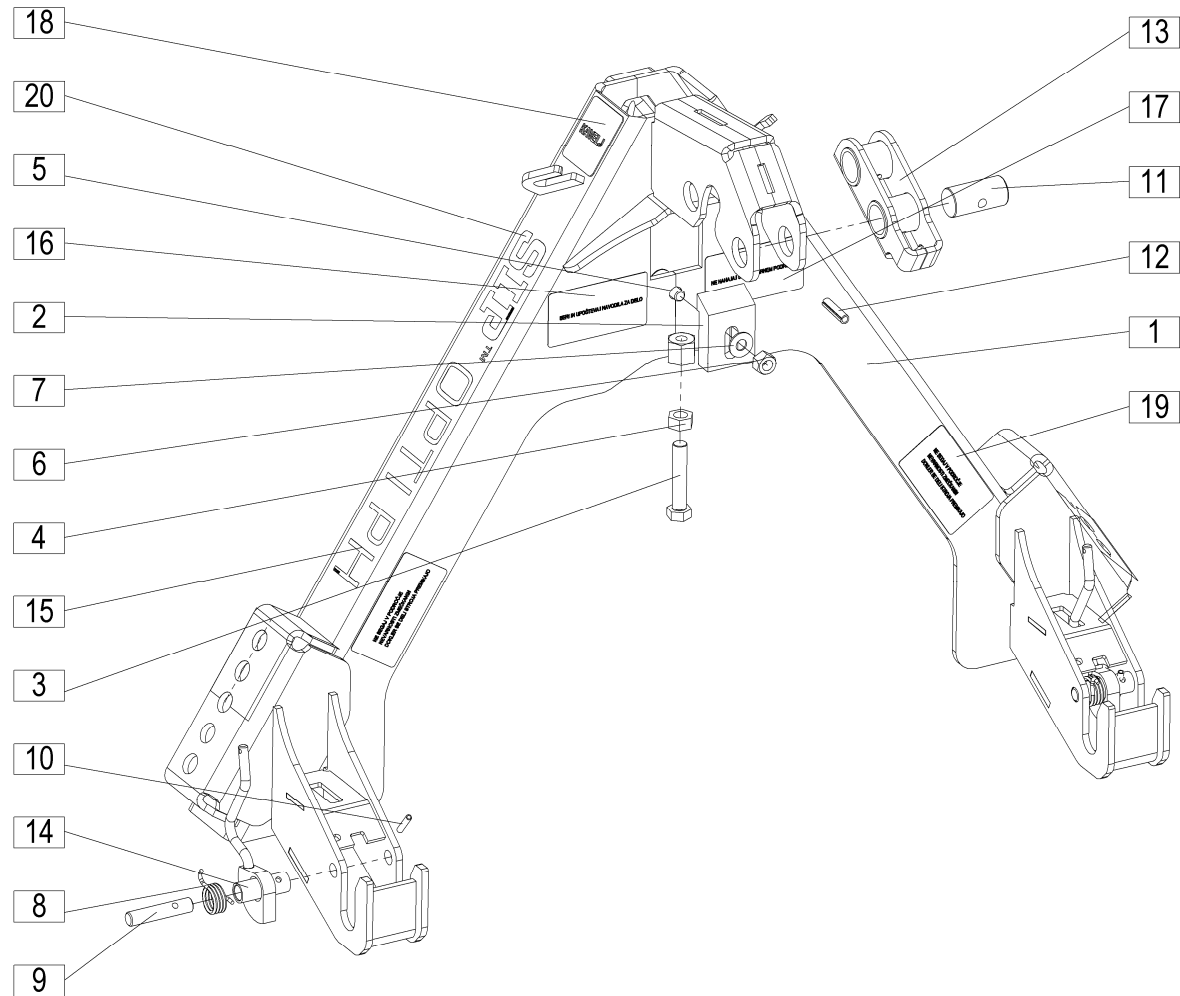

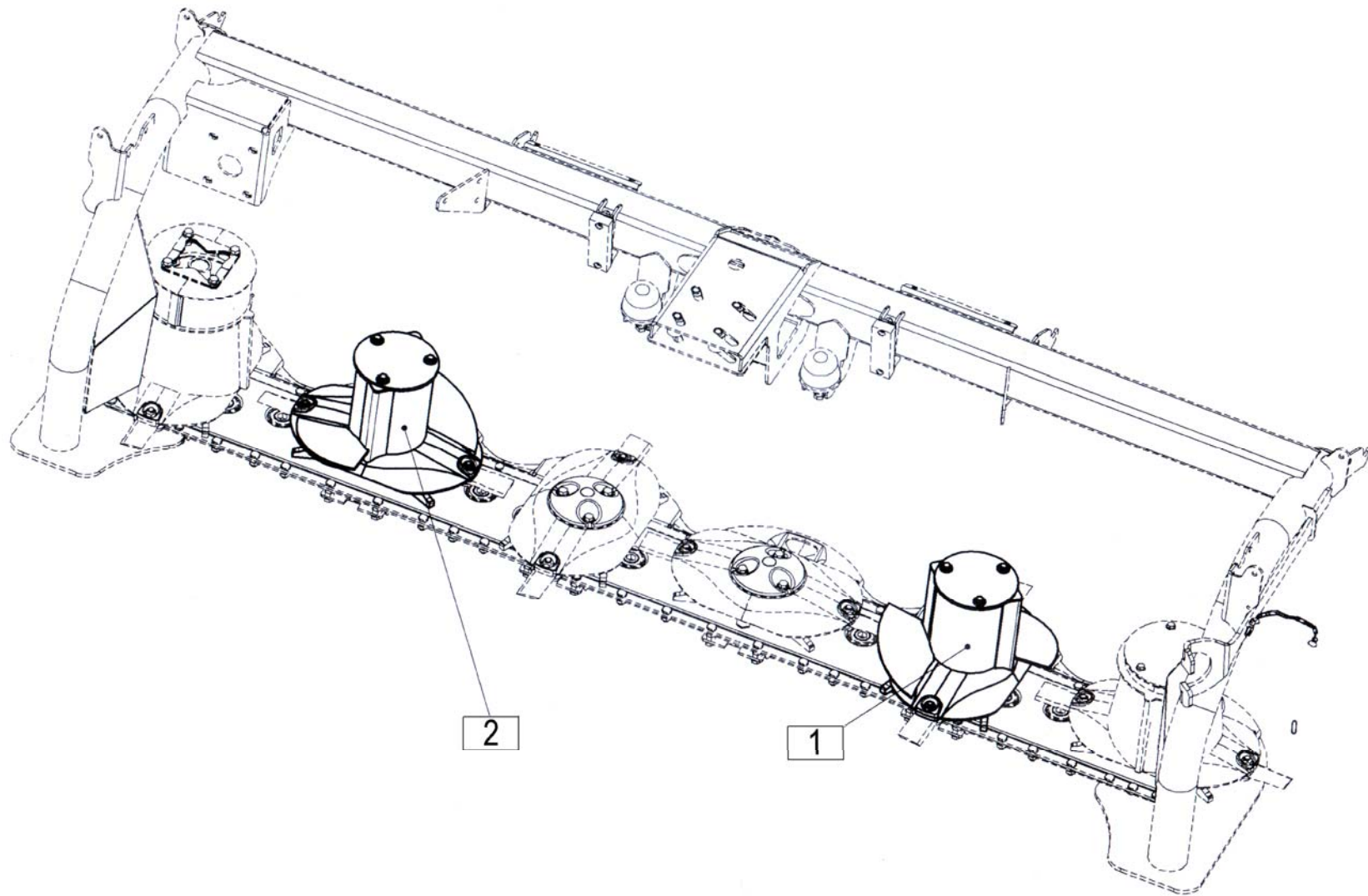

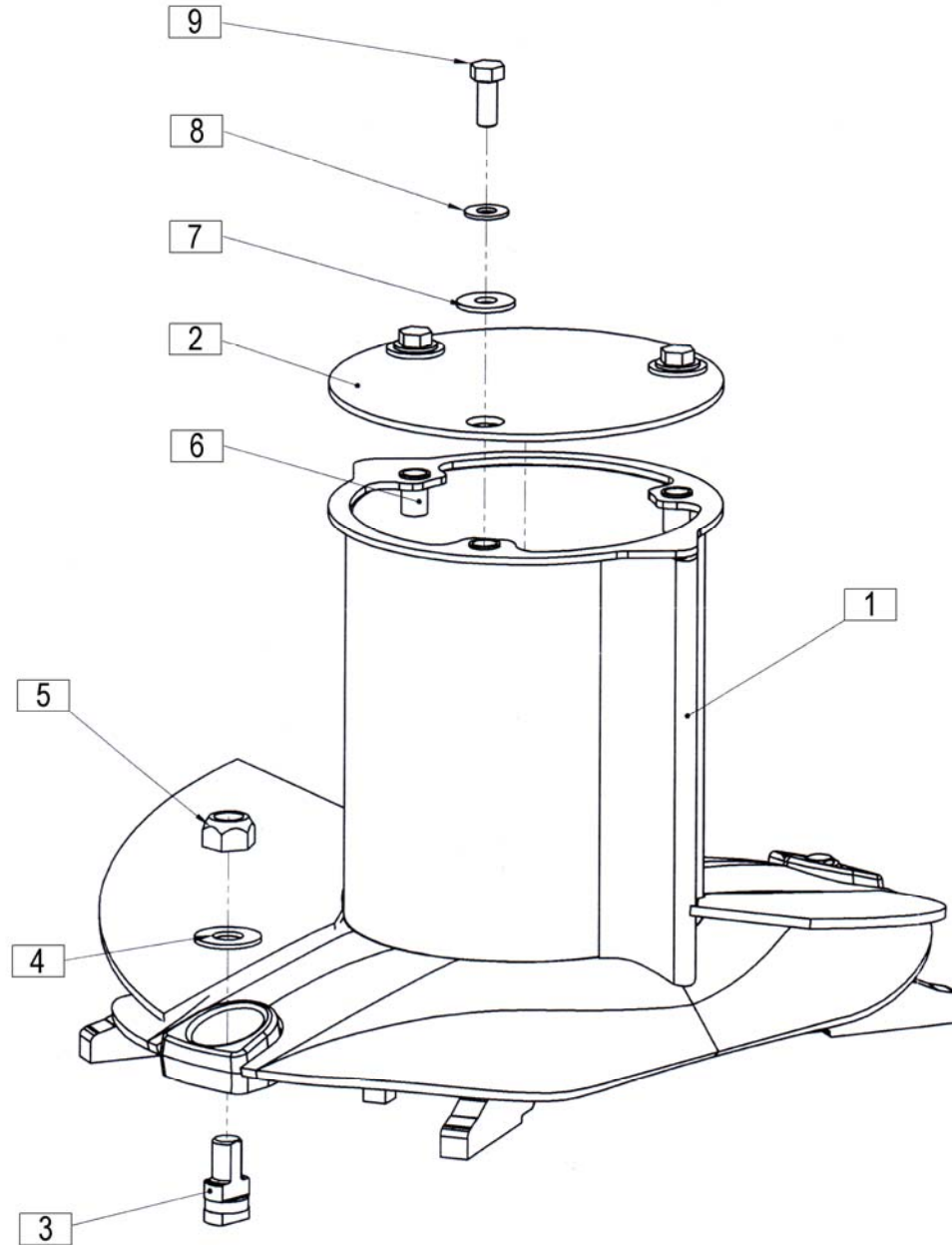

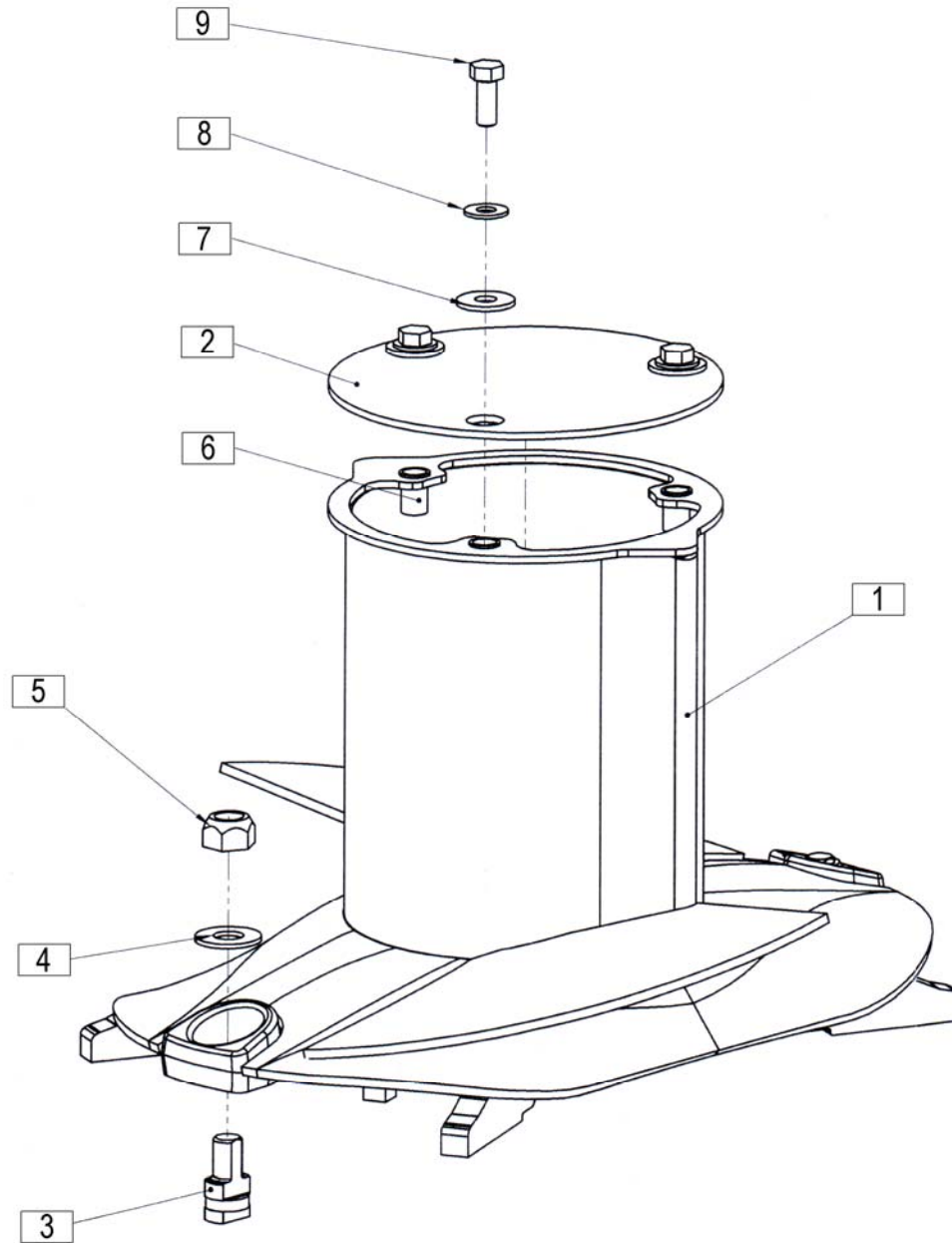

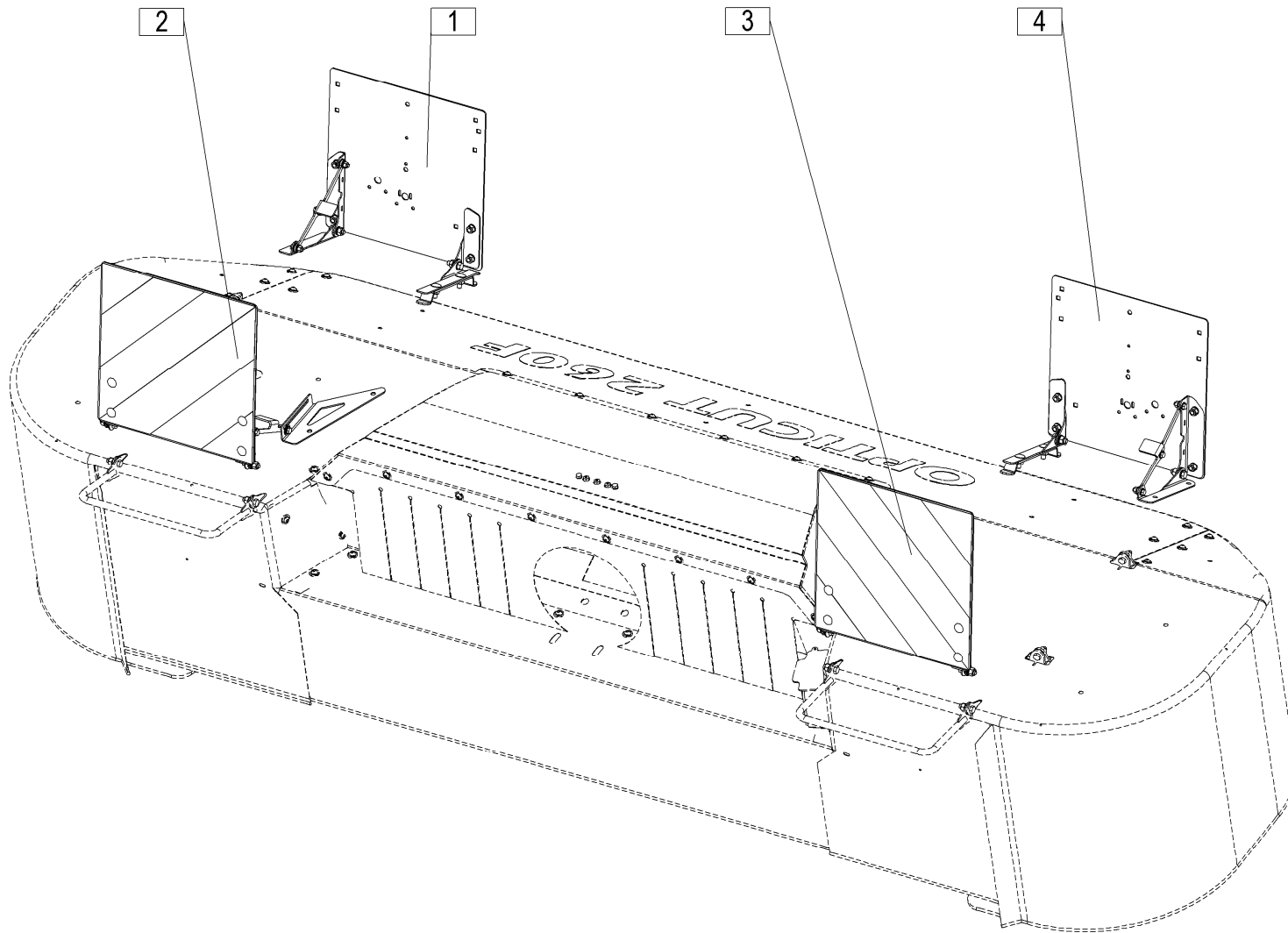

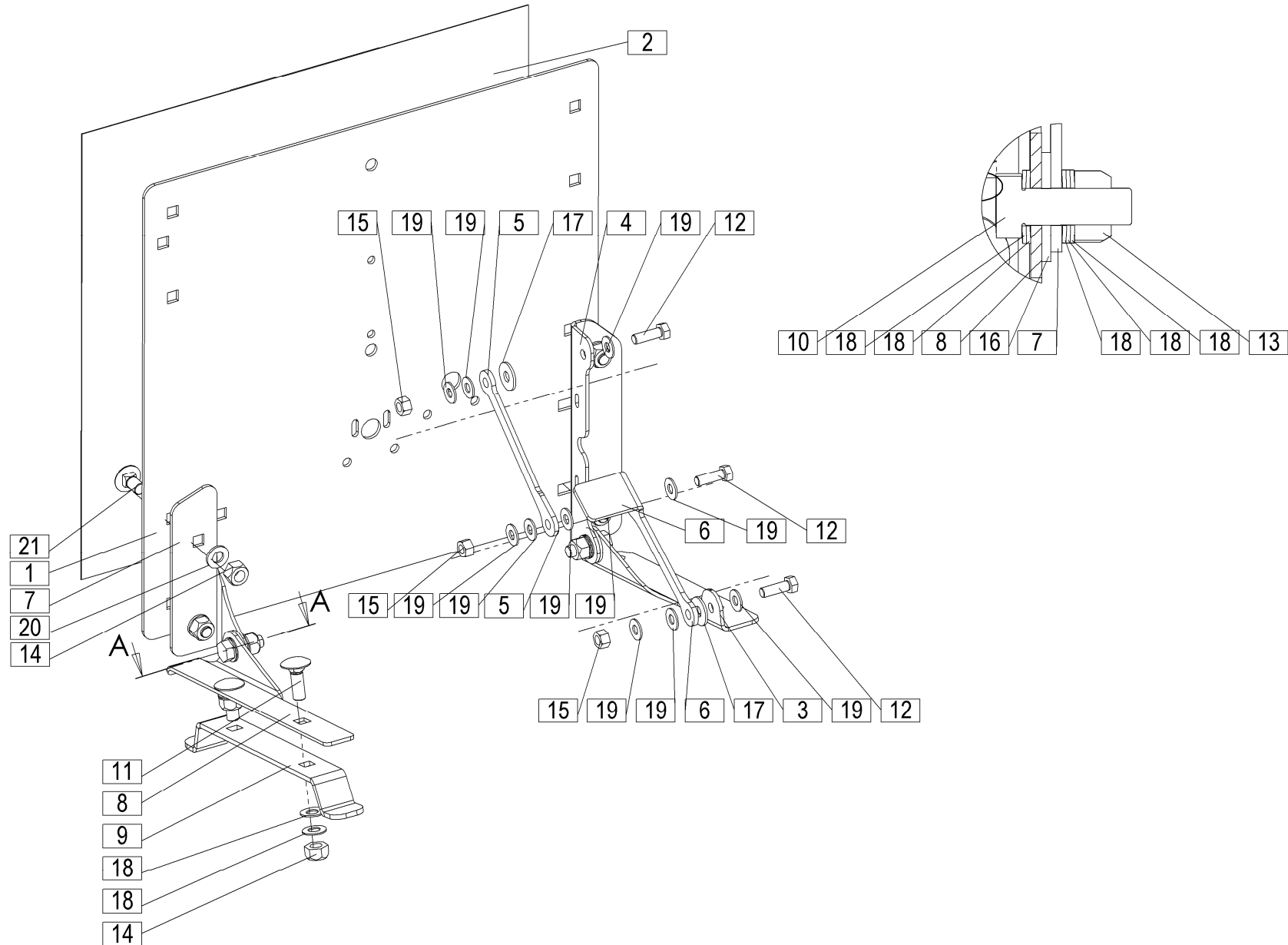

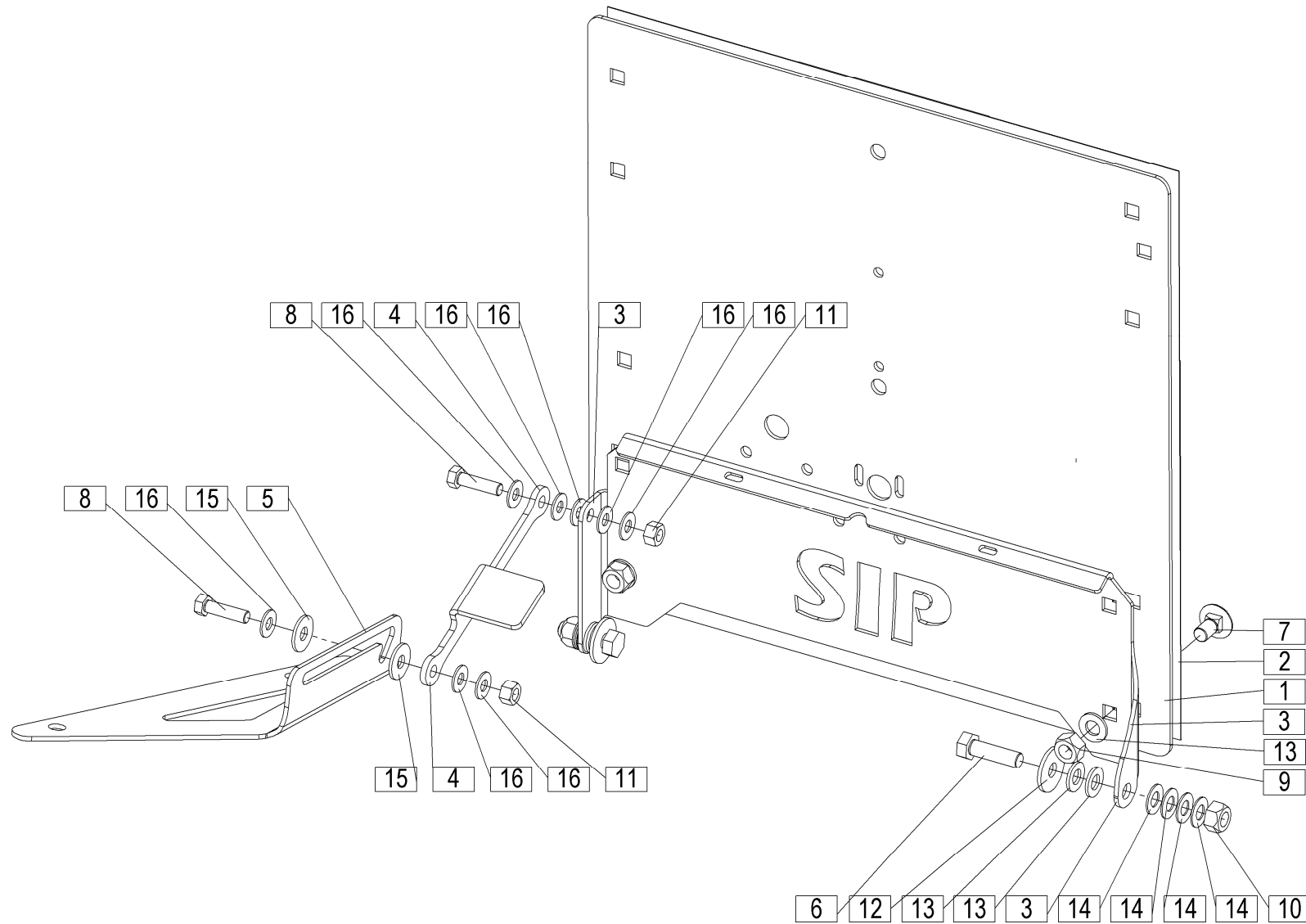

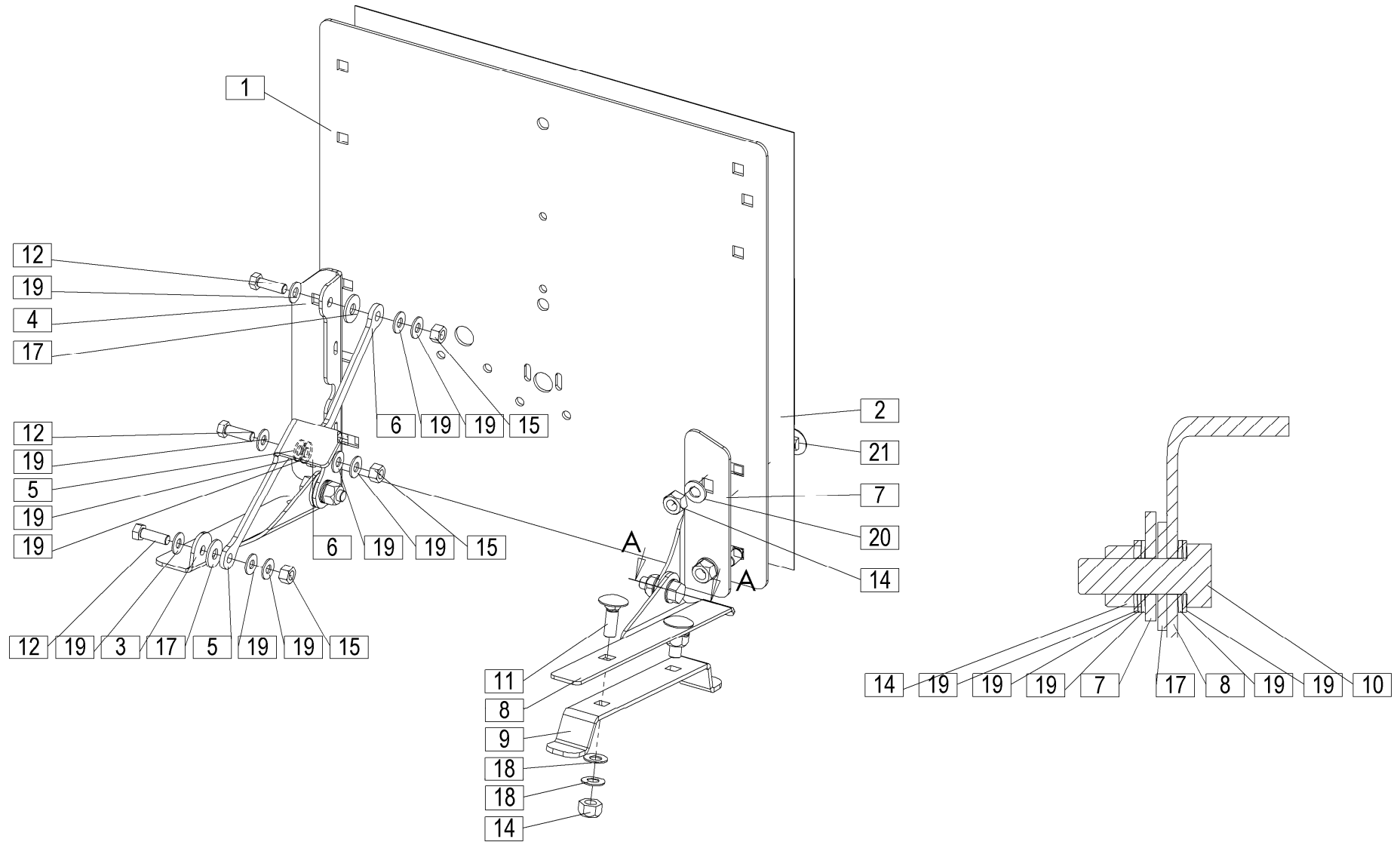

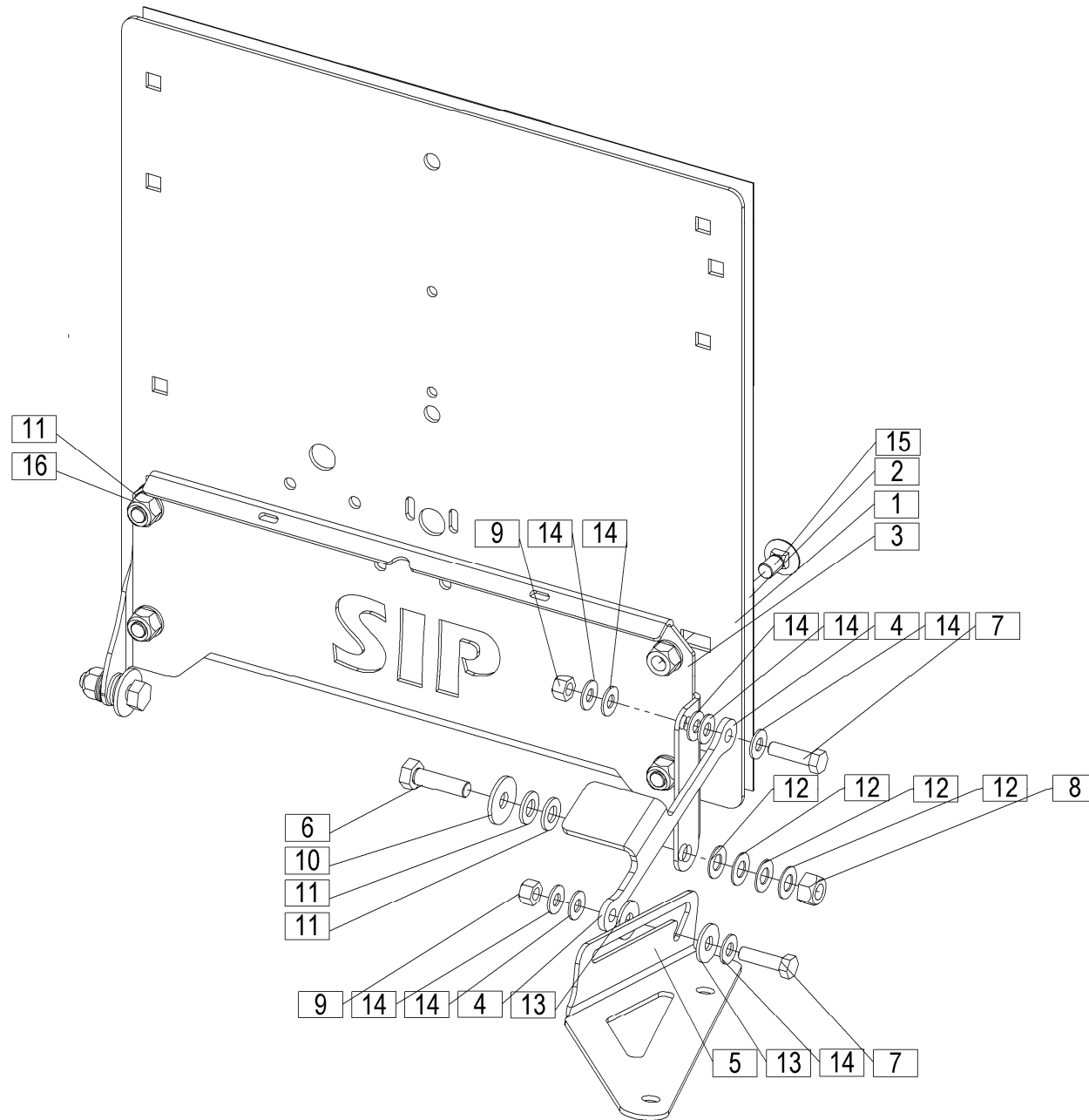

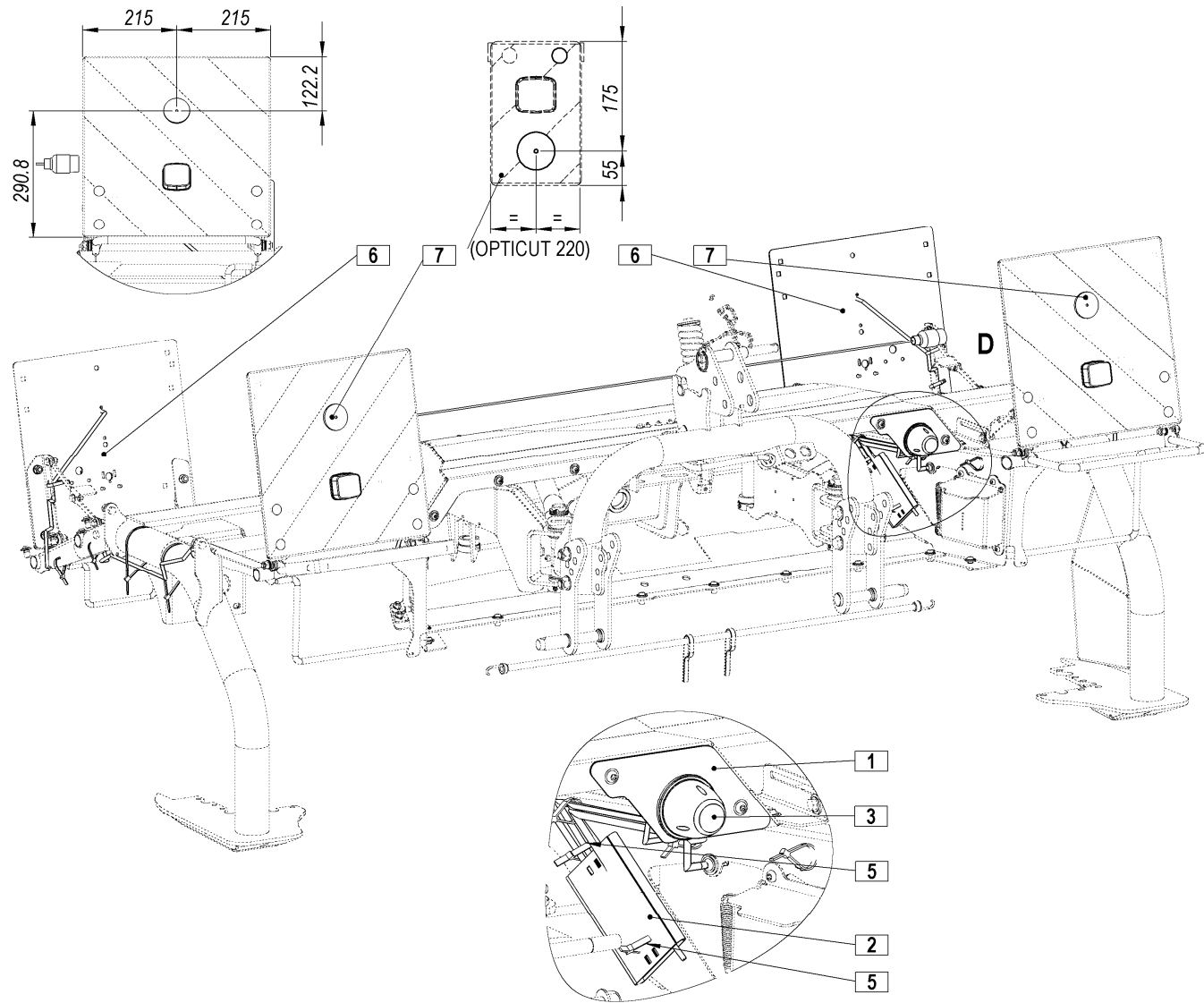

Prüfert Nr.: 60 931

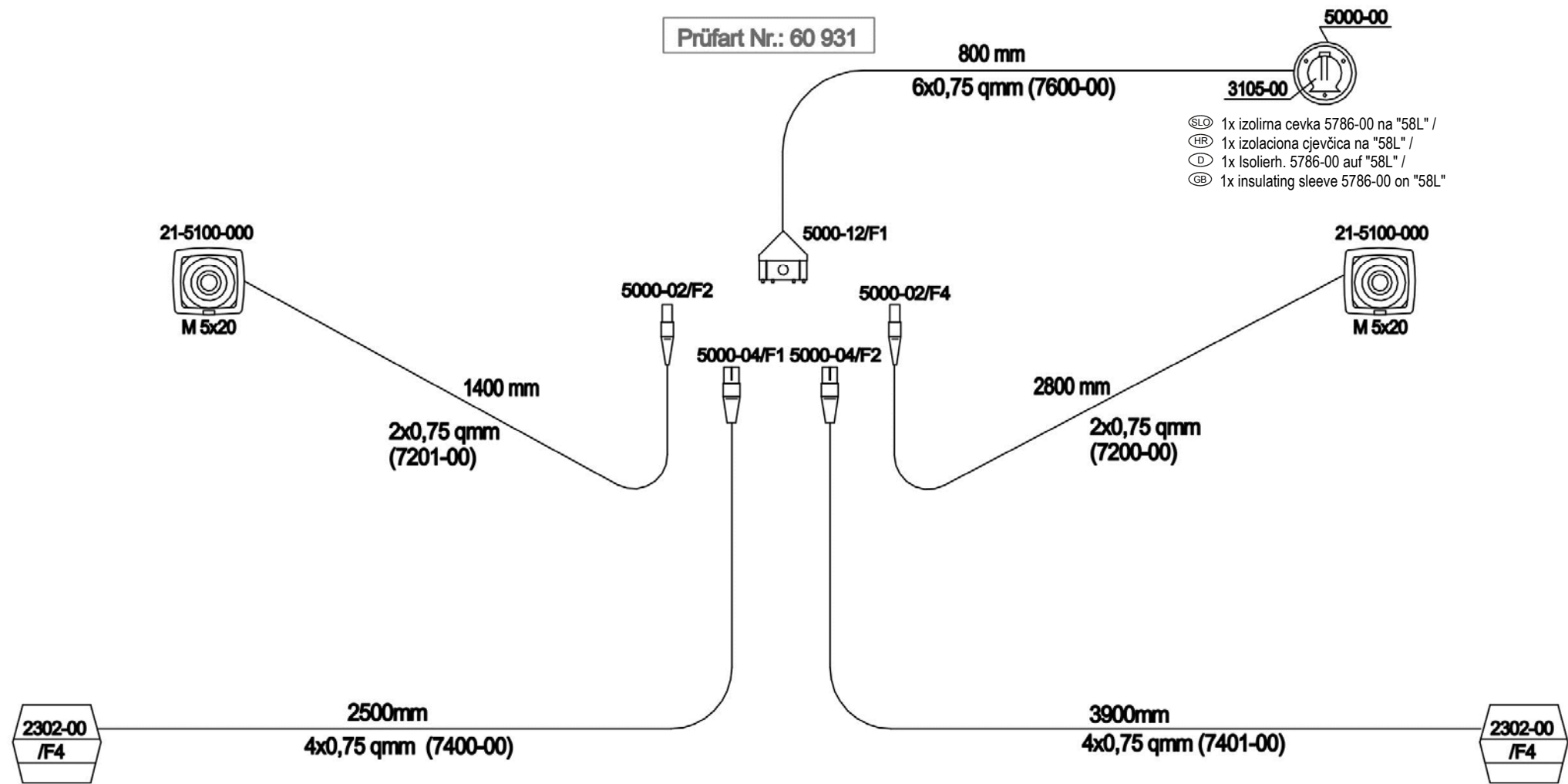

Koda za naročilo.: AA-8240-08
 Koda za narudžbu: AA-8240-08
 Bestell-Nr.: AA-8240-08
 Order No: AA-8240-08

Oprema svetlobna
 Svetlosna oprema

Beleuchtung
 Electrical illumination

(12 VOLT)
 Ident: 764200950

OPTICUT DISC 260 F ALP=+197

DODATNA OPREMA SONDERAUSRÜSTUNG – ZUSATZTEILE ADDITIONAL EQUIPMENT ÉQUIPEMENT ADDITIONNEL ATTREZZATURA AGGIUNTIVA				Velja od tov. št. dalje: Važi od tvor. broja dalje: Ab masch. Nr.: From mach Nr.: Da macch. Nr.: N° de machine :				OPTICUT DISC 260 F ALP=+197		42
--	--	--	--	---	--	--	--	------------------------------------	--	-----------

Številka Broj Bild Fig. Fig. N°	Kataloška številka Kataloški broj Ersatzteilnummer Spare Part Number Numero Parti di Ricambio Numéro de la pièce de rechange	Naziv dela (SLO)	Naziv dijela (HR)	Benennung (D)	Description (GB)	Descrizione (I)	Description (F)	Količina Komada Menge Quantity Quantità
	764200950	Svetlobna oprema (ASPOCK)	Svetlosna oprema (ASPOCK)	Beleuchtung (ASPOCK)	Electrical illumination (ASPOCK)	Illuminazione elettrica (ASPOECK)	Illumination électrique (ASPOECK)	1

	DODATNA OPREMA:	(SLO) (CRO)
4 kos	4808-00	odklopnik/ otkačnik
2 kos	5411-01	odsevník/60mm/samolepilni/ refleksijsko staklo /60mm /samoljepilno
2 kos	5410-01	odsevník/60mm/samolepilni/ refleksijsko staklo /60mm /samoljepilno
8 kos	S500-00	matica M5/ matica M5
8 kos	S502-00	zubata podložka M5/ zubata podložka M5

	ZUBEHÖR / ACCESSORIES:	(D) (GB)
4 Stk. / pcs	4808-00	Zugentlastungen/ strain relief
2 Stk. / pcs	5411-01	Strahler rt/60mm/selbstkl. spotlight /60 mm/ selfadhesive
2 Stk. / pcs	5410-01	Strahler ws/60mm/selbstkl. spotlight /60 mm/ selfadhesive
8 Stk. / pcs	S500-00	Muttern M5/ Screw nut M5
8 Stk. / pcs	S502-00	Zahnscheiben M5/ tooth lock washer M5

Prüfart Nr.: 60 931

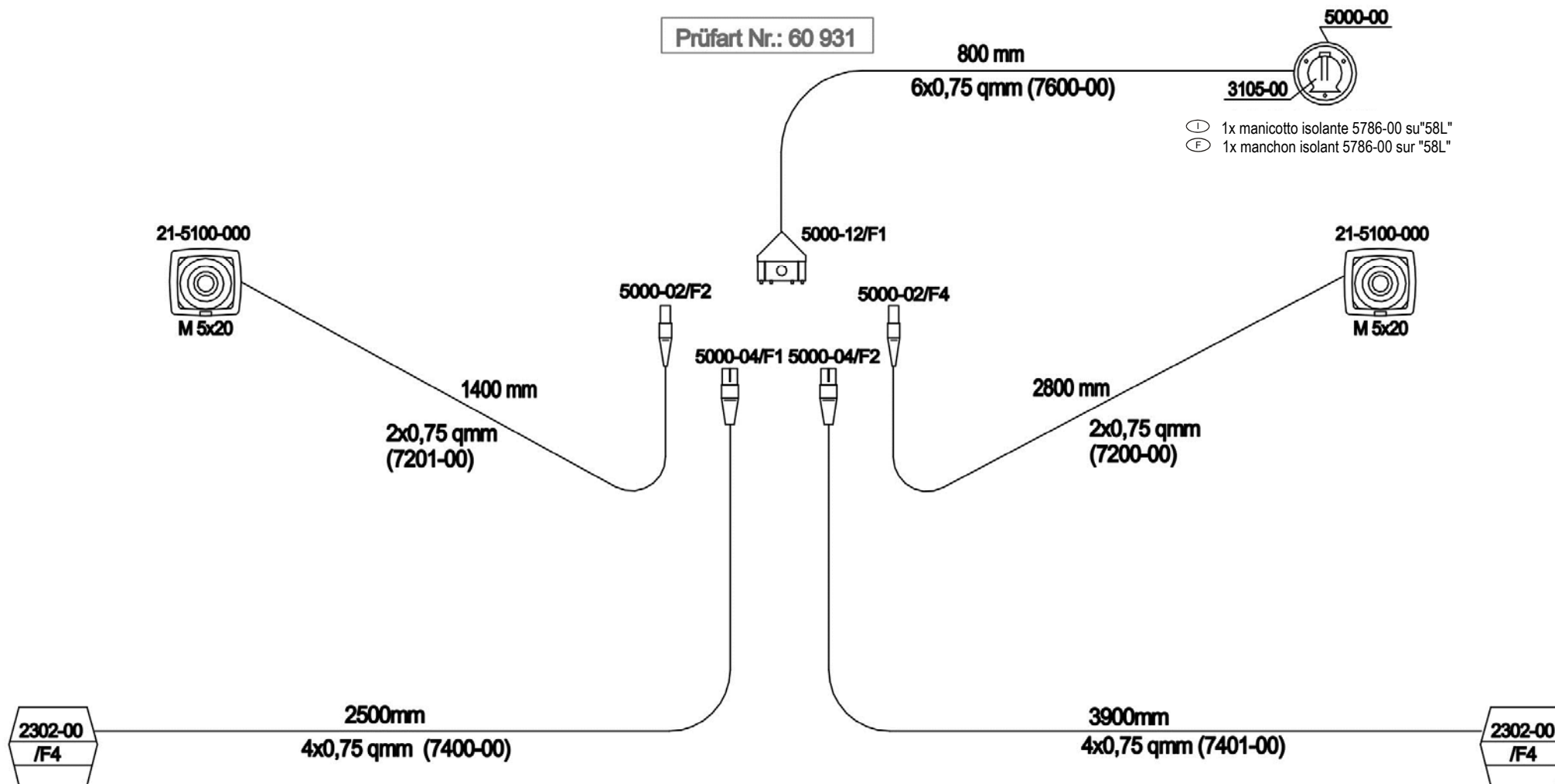

DODATNA OPREMA SONDERAUSRÜSTUNG – ZUSATZTEILE ADDITIONAL EQUIPMENT ÉQUIPEMENT ADDITIONNEL ATTREZZATURA AGGIUNTIVA				Velja od tov. št. dalje: Važi od tvor. broja dalje: Ab masch. Nr.: From mach Nr.: Da macch. Nr.: N° de machine :			OPTICUT DISC 260 F ALP=+197		42
--	--	--	--	---	--	--	------------------------------------	--	-----------

Številka Broj Bild Fig. Fig. N°	Kataloška številka Kataloški broj Ersatzteilnummer Spare Part Number Numero Parti di Ricambio Numéro de la pièce de rechange	Naziv dela (SLO)	Naziv dijela (HR)	Benennung (D)	Description (GB)	Descrizione (I)	Description (F)	Količina Komada Menge Quantity Quantità
	764200950	Svetlobna oprema (ASPOCK)	Svetlosna oprema (ASPOCK)	Beleuchtung (ASPOCK)	Electrical illumination (ASPOCK)	Illuminazione elettrica (ASPOECK)	Illumination électrique (ASPOECK)	1

ACCESSORI:		(I)
4 pez.	4808-00	serracavo:
2 pez.	5411-01	faretto/60 mm/autoadesivo
2 pez.	5410-01	faretto/60 mm/autoadesivo
8 pez.	S500-00	dado M5
8 pez.	S502-00	rondella blocca denti M5

ACCESSOIRES:		(F)
4 pcs	4808-00	détente de la contrainte
2 pcs	5411-01	projecteur/60 mm/ auto-adhésif
2 pcs	5410-01	projecteur/60 mm/ auto-adhésif
8 pcs	S500-00	Vis écrou M5.
8 pcs	S502-00	rondelle à dents M5

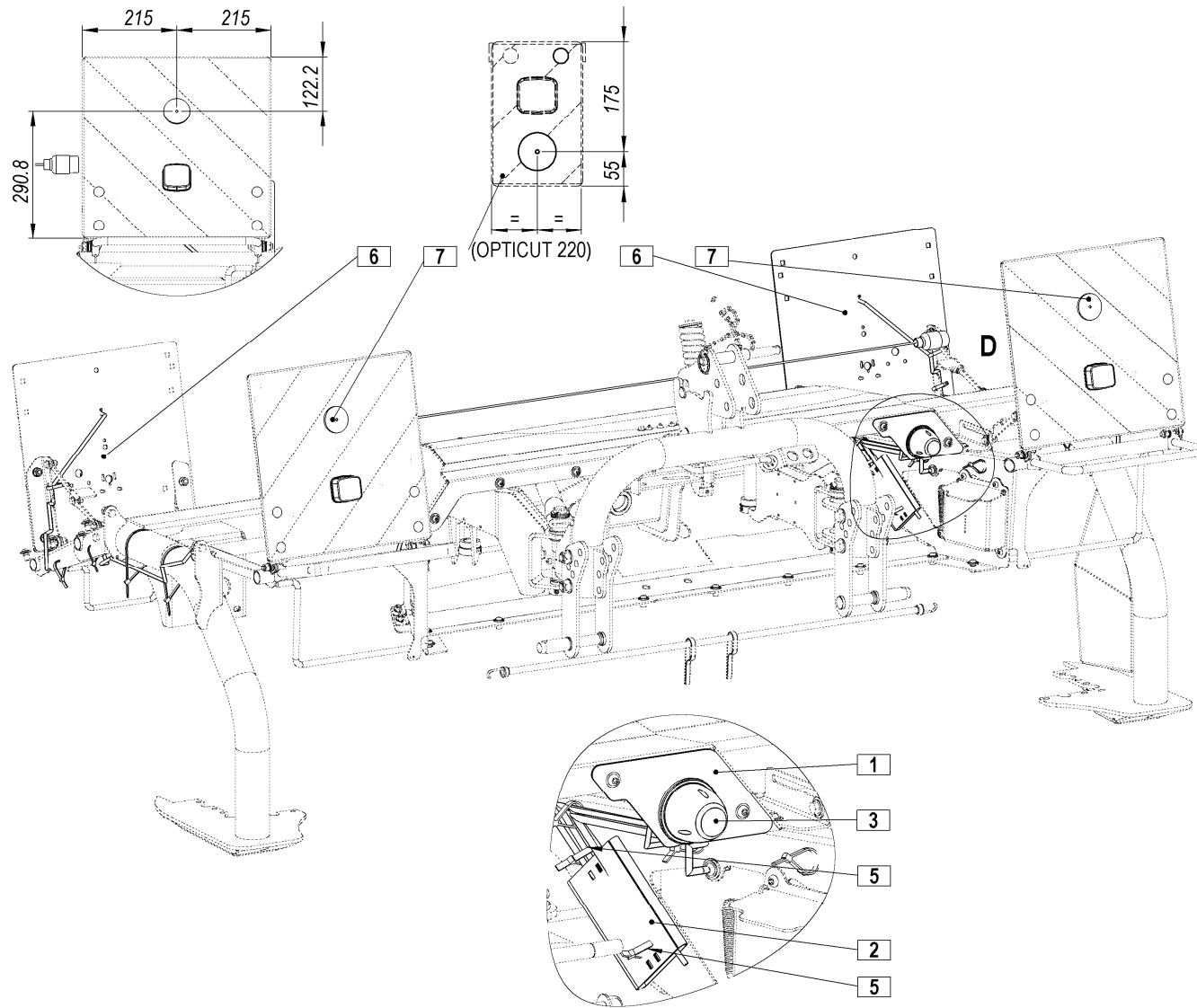

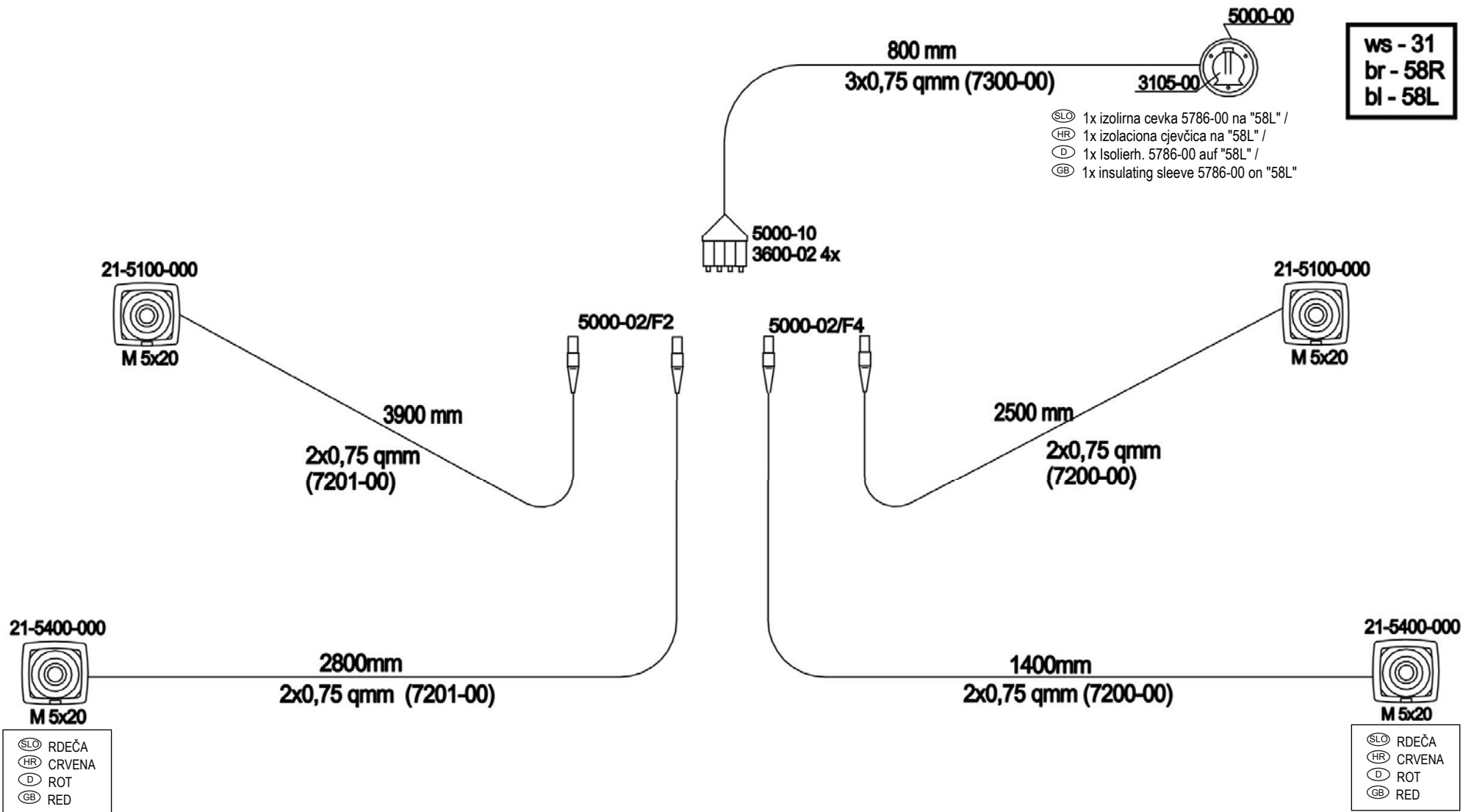

ws - 31
br - 58R
bl - 58L

- ⓈLO 1x izolirna cevka 5786-00 na "58L" /
- ⓂHR 1x izolaciona cjevčica na "58L" /
- ⓍD 1x Isolierh. 5786-00 auf "58L" /
- ⓂGB 1x insulating sleeve 5786-00 on "58L"

Oprema svetlobna
Svetlosna oprema

Beleuchtung
Electrical illumination

(12 VOLT)
Ident: 764200960

Koda za naročilo.: AA-8240-09
Koda za narudžbu: AA-8240-09
Bestell-Nr.: AA-8240-09
Order No: AA-8240-09

OPTICUT DISC 260 F ALP=+197

DODATNA OPREMA SONDERAUSRÜSTUNG – ZUSATZTEILE ADDITIONAL EQUIPMENT ÉQUIPEMENT ADDITIONNEL ATTREZZATURA AGGIUNTIVA				Velja od tov. št. dalje: Važi od tvor. broja dalje: Ab masch. Nr.: From mach Nr.: Da macch. Nr.: N° de machine :				OPTICUT DISC 260 F ALP=+197		43a	
Številka Broj Bild Fig. Fig. N°	Kataloška številka Kataloški broj Ersatzteilnummer Spare Part Number Numero Parti di Ricambio Numéro de la pièce de rechange	Naziv dela (SLO)	Naziv dijela (HR)	Benennung (D)	Description (GB)	Descrizione (I)	Description (F)		Količina Komada Menge Quantity Quantità		
	764200960	Svetlobna oprema (ASPOCK)	Svetlosna oprema (ASPOCK)	Beleuchtung (ASPOCK)	Electrical illumination (ASPOCK)	Illuminazione elettrica (ASPOECK)	Illumination électrique (ASPOECK)		1		

	DODATNA OPREMA:	(SLO) (CRO)
4 kos	4808-00	odklopnik/ otkačnik
2 kos	5411-01	odsevník/60mm/samolepilni/ refleksijsko staklo /60mm /samoljepilno
2 kos	5410-01	odsevník/60mm/samolepilni/ refleksijsko staklo /60mm /samoljepilno
8 kos	S500-00	matica M5/ matica M5
8 kos	S502-00	zubata podložka M5/ zubata podložka M5

	ZUBEHÖR / ACCESSORIES:	(D) (GB)
4 Stk. / pcs	4808-00	Zugentlastungen/ strain relief
2 Stk. / pcs	5411-01	Strahler rt/60mm/selbstkl. spotlight /60 mm/ selfadhesive
2 Stk. / pcs	5410-01	Strahler ws/60mm/selbstkl. spotlight /60 mm/ selfadhesive
8 Stk. / pcs	S500-00	Muttern M5/ Screw nut M5
8 Stk. / pcs	S502-00	Zahnscheiben M5/ tooth lock washer M5

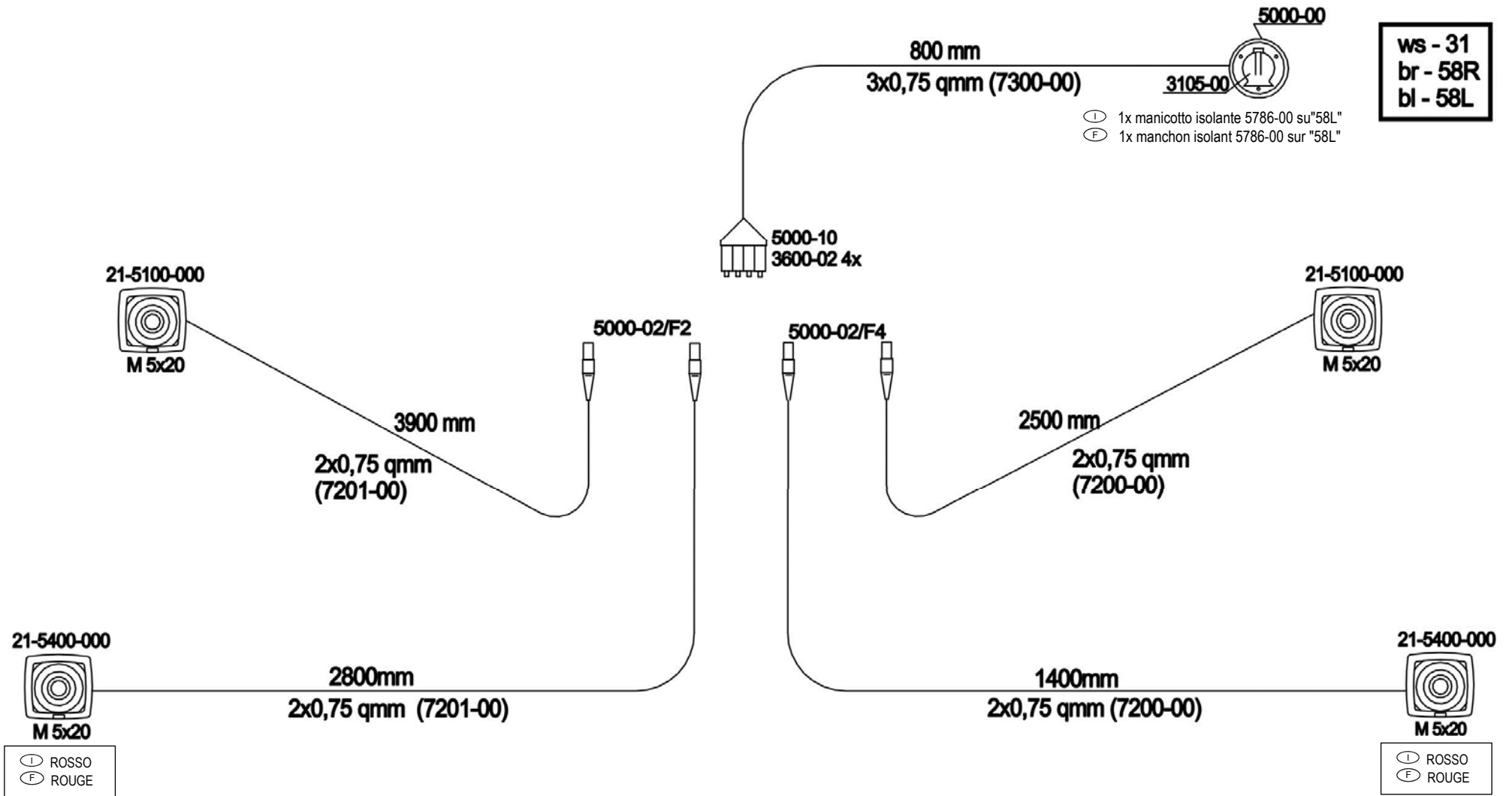

illuminazione elettrica
 Illumination électrique

(12 VOLT)
 Ident: 764200960

Ordine Nr.: AA-8240-09
 Commande n°: AA-8240-09

OPTICUT DISC 260 F ALP=+197

DODATNA OPREMA SONDERAUSRÜSTUNG – ZUSATZTEILE ADDITIONAL EQUIPMENT ÉQUIPEMENT ADDITIONNEL ATTREZZATURA AGGIUNTIVA				Velja od tov. št. dalje: Važi od tvor. broja dalje: Ab masch. Nr.: From mach Nr.: Da macch. Nr.: N° de machine :				OPTICUT DISC 260 F ALP=+197		43a	
--	--	--	--	---	--	--	--	------------------------------------	--	------------	--

Številka Broj Bild Fig. Fig. N°	Kataloška številka Kataloški broj Ersatzteilnummer Spare Part Number Numero Parti di Ricambio Numéro de la pièce de rechange	Naziv dela (SLO)	Naziv dijela (HR)	Benennung (D)	Description (GB)	Descrizione (I)	Description (F)		Količina Komada Menge Quantity Quantità Quantité
	764200960	Svetlobna oprema (ASPOCK)	Svetlosna oprema (ASPOCK)	Beleuchtung (ASPOCK)	Electrical illumination (ASPOCK)	Illuminazione elettrica (ASPOECK)	Illumination électrique (ASPOECK)		1

	ACCESSORI:	(I)
4 pez.	4808-00	serracavo:
2 pez.	5411-01	faretto/60 mm/autoadesivo
2 pez.	5410-01	faretto/60 mm/autoadesivo
8 pez.	S500-00	dado M5
8 pez.	S502-00	rondella blocca denti M5

	ACCESSOIRES:	(F)
4 pcs	4808-00	détente de la contrainte
2 pcs	5411-01	projecteur/60 mm/ auto-adhésif
2 pcs	5410-01	projecteur/60 mm/ auto-adhésif
8 pcs	S500-00	Vis écrou M5.
8 pcs	S502-00	rondelle à dents M5

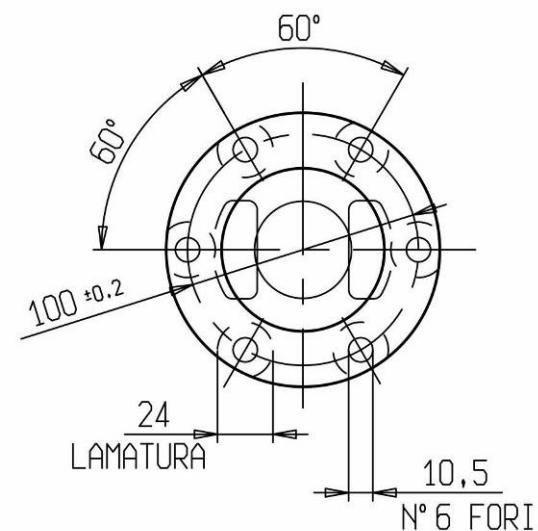
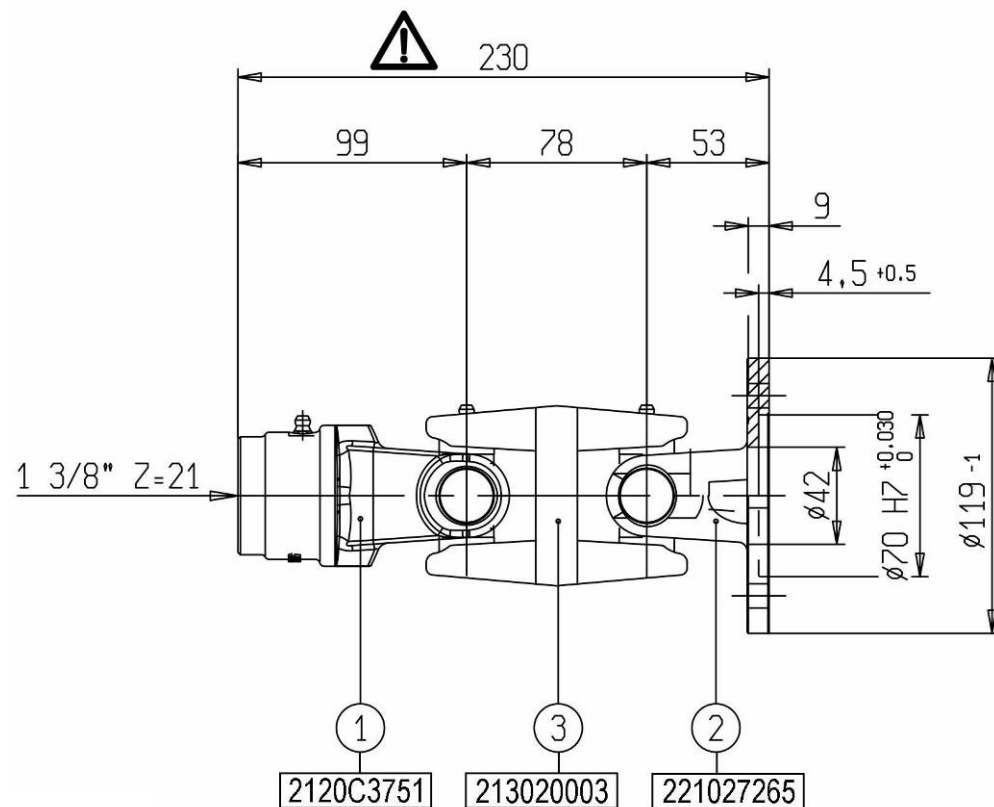

KARDAN.112.0

Ident: 150676806

KARDAN.112.0
GELENKWELLE.112.0
P.T.O. SHAFT.112.0

Ident: 150676806

ALBERO CARDANICO.112.0 ARBRE DE TRANSMISSION.112.0

OPTICUT DISC 260 F ALP=+197

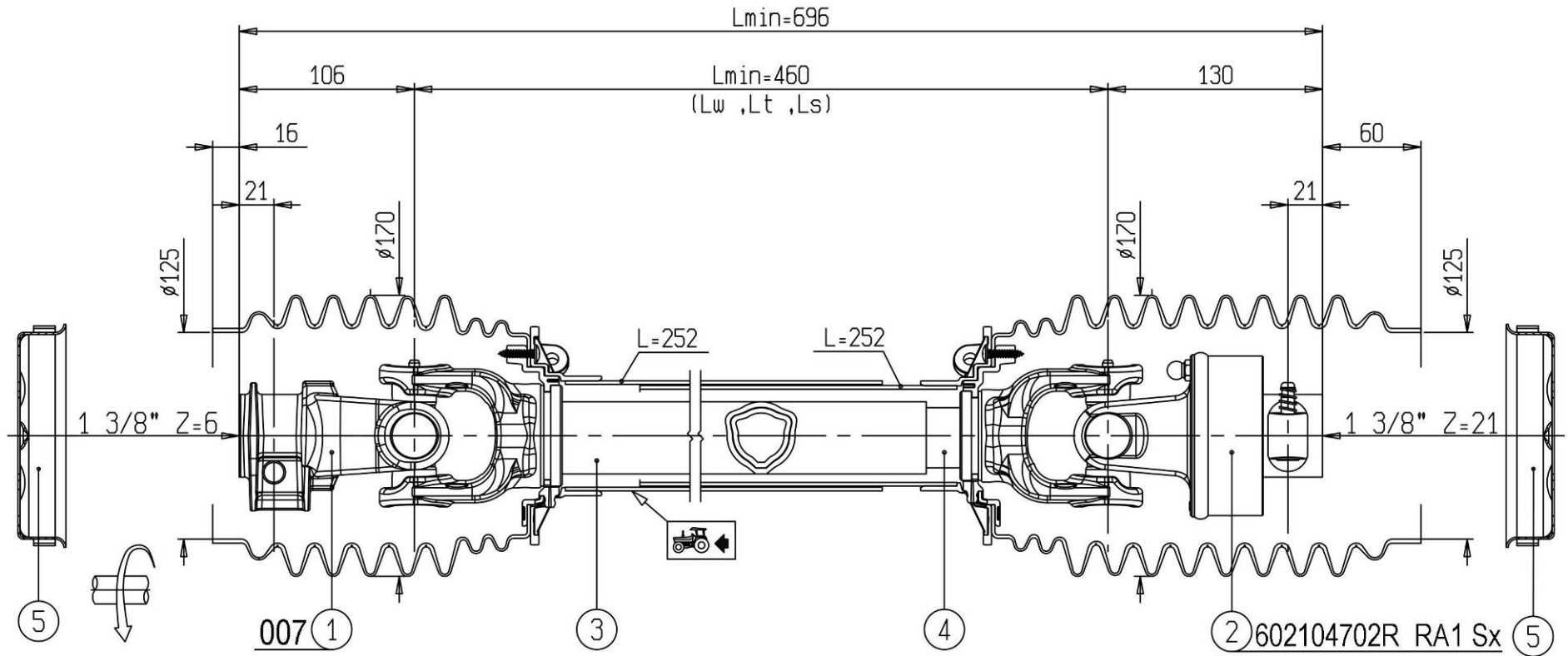

KARDAN.115.0

Ident: 150683004

KARDAN.115.0
GELENKWELLE.115.0
P.T.O. SHAFT.115.0

Ident: 150683004

ALBERO CARDANICO.115.0 ARBRE DE TRANSMISSION.115.0

OPTICUT DISC 260 F ALP=+197

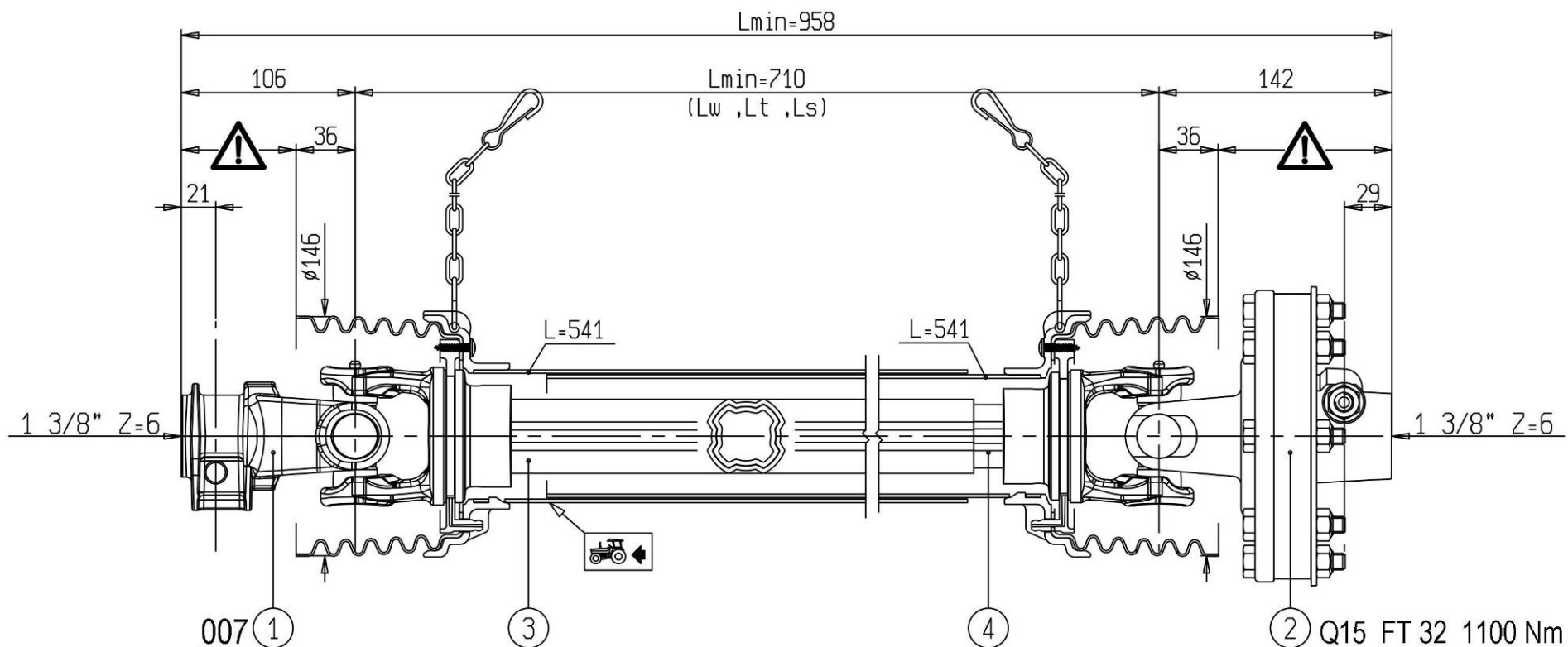

KARDAN.118.0

Ident: 150697909

KARDAN.118.1

Ident: 150706908

KARDAN.118.0
GELENKWELLE.118.0

Ident: 150697909

KARDAN.118.1
GELENKWELLE.118.1

Ident: 150706908

P.T.O. SHAFT.118.0
ALBERO
CARDANICO.118.0

ARBRE DE
TRANSMISSION.118.0

ALBERO
CARDANICO.118.1

ARBRE DE
TRANSMISSION.118.1

OPTICUT DISC 260 F ALP=+197

SLOVENIJA

<p>SIP ŠEMPETER d.d. 3311 ŠEMPETER V SAVINJSKI DOLINI Tel: 03 70 38 500 Reklamacije: (0)3 70 38 562 Fax: 03 70 38 665</p>	<p>SMOLIČ JOŽE Artmanja vas 7, 8211 DOBRNIČ Tel: 07 34 65 600 Fax: 07 34 65 389 GSM: 041 693 221</p>	<p>KMETIJSTVO POLANEC d.o.o Pleterje 34 2324 LOVRENC NA DRAVSKEM POLJU Tel: 02 761 9300 Fax: 02 761 9306</p>
<p>KMETIJSKI CENTER LAH Klanec 13 1218 KOMENDA Tel: 01 8341 022 Tel: 01 8342 070 Tel: 01 8342 080 Tel: 01 8342 212 Fax: 01 8345 505</p>	<p>RIKOTECH d.o.o. Lepovče 23, 1310 RIBNICA Tel. / fax.: 01 83 61 483 GSM: 041 72 43 98</p>	<p>AVTO CENTER ORMOŽ d.o.o. Hardek 44/c, 2270 ORMOŽ Fax: 02 7416 410 Tel: 02 74 16 405 (servis) GSM: 031 322 939 Tel: 02 74 16 407 (trgovina) GSM: 031 891 529</p>
<p>CREINA KRANJ Vodnova 8, 4000 KRANJ Tel: 04 20 13 360 (centrala) Tel: 04 20 13 355 (servis) Fax: 04 20 13 363</p>	<p>KZ KRKA z.o.o. OC AGROSERVIS Novo Mesto Knafelčeva 2 8000 NOVO MESTO Tel: 07 393 01 11 Fax: 07 393 01 25 Tel: 07 393 01 10</p>	<p>ŽIBRAT JANI Mota 32, 9240 LJUTOMER Tel: 02 584 1130 Fax: 02 584 1130 GSM: 041 713 300</p>
<p>AVTO ERŽEN d.o.o. Podjelovo Brdo 1, 4225 SOVODENJ Tel: 04 510 80 70 Fax: 04 510 80 77 GSM: 041 721 706</p>	<p>JAKŠE SAMO Prvomajska c. 22 8310 ŠENTJERNEJ Fax / Tel: 07 3081 309</p>	<p>FRANC ŠTAMUL s.p. Vuhred 125 2365 VUHRED Fax / Tel: 02 88 73 751 GSM: 041 332 684</p>
	<p>TOMC MARJAN Primostek 6 8332 GRADAC Tel: 07 30 58 513 GSM: 041 685 133</p>	

HRVAŠKA

MF SERVIS Filipčič Milorad Gradec 9, 10345 GRADEC Tel: ++385 01 897 058 GSM: 098 248 267	PROIZVODNA OPRUGA DEŽANOVAC DEŽANOVAC Tel: ++385 43 381 333 Tel: ++385 43 381 366 (trgovina) Fax: ++385 43 381 330	AGM PANEX ČAKOVEC Zagrebačka 101, 40300 ČAKOVEC Tel: ++385 40 384 144 Tel: ++385 40 384 354 Tel: ++385 40 384 351 (servis) Fax: ++385 40 384 355
BOŽIČ VLADO Brače Radiča 50 42232 MARTIJANEC Tel: ++385 42 673 020 GSM: 099 420 927	ALKAR d.o.o. Dubrovačka 67, 34000 POŽEGA Tel: ++385 34 274 671 Fax: ++385 34 273 433 GSM: 098 362 996 GSM: 098 365 211	ALSO d.o.o. Končanica 355 43505 KONČANICA Tel: ++385 43 325 124 GSM: 091 56 13 600

BOSNA IN HERCEGOVINA

P.P. MABI Mrkodol h.h. 80240 TOMISLAVGRAD Tel: ++387 34 310 100	AGROCOOP KOBATOVCI 78255 BOSANSKI ALEKSANDROVAC Tel: ++387 51 582 041 (servis) GSM: ++387 65 510 290, Fax: ++387 51 580 800	ACMA d.o.o. Ljusina b.b. 77244 BOS. OTOKA Tel: ++387 37 477 018 Fax: ++387 37 477 039 GSM: ++387 61 155 905
---	---	---

SRBIJA IN ČRNA GORA

AGRO DRINIA 38400 PRIZREN KOSOVO Tel / Fax: ++381 29 44 335 GSM: ++377 44 113 137	JUGOMETAL d.o.o. Kušljevački put b.b., 35210 SVILAJNAC Tel: ++381 35 312 391 Tel: ++381 35 312 027 Tel: ++381 35 311 696, Fax: ++381 35 312 331	AGROAUTO PODGORICA Ul. Bracana Bracanoviča 76 81412 SPUŽ Tel: ++381 81 881 784 Fax: ++381 81 636 290
--	--	---

MAKEDONIJA

	EURO POLOG 1226 Zheline, TETOVO Tel: ++389 44 379 379, Fax: ++389 44 378 236	
--	---	--

SIP d.d. Šempeter si pridržuje pravico do morebitnih sprememb v katalogu