

*Instruction for work
Betriebsanleitung*

*List of spare parts
Ersatzteilliste*



SIP

ORION 40 R-PRO, 40 R-ST

manure spreader

stahldungstreuer

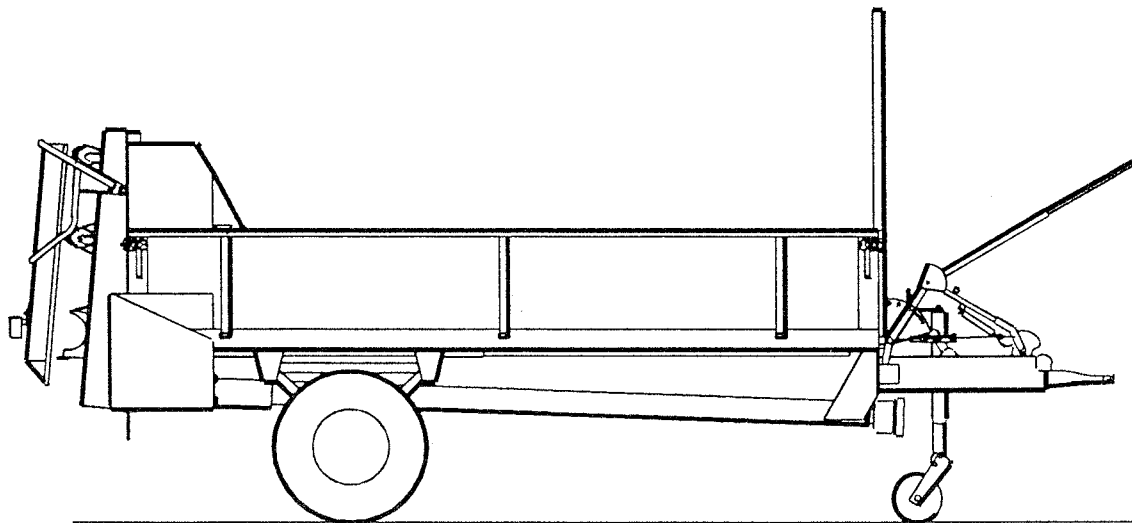

Valid from serial number on:

Gültig ab Maschinnummer:

ORION 40 R-PRO=011-025

ORION 40 R-ST =026-060



SIP

STROJNA INDUSTRIJA d.o.o.
3311 Šempeter v Savinjski dolini
SLOVENIJA

Tel: +386 (0)63 702 211

Fax: +386 (0)63 702 131

702 134

154144606

ERSATZTEILLISTE

SPARE PARTS LIST

ORION 40 R-PRO, 40 R-ST

Numer anzeichn. No. on the figure	Katalog nummer Catalogue no.	Benennung	Description	Stück Quantity
1	154115503-627.04.002.0	Welle schw.	Shaft	1
2	154123308-627.04.004.0	Stutzlager kpl.	Bearing	1
3	154123709-627.04.010.0	Stutzschutz schw.	Suport	1
4	154124003-627.04.014.0	Schraube 7	Screw 7	2
5	153195205-619.10.065.0	Gelenkwelleschutz	P.T.O Shaft	1
6	151272205-600.04.005.1	Lagergehäuse	Bearing housing	1
7	151273204-600.04.009.1	Getriebgehäuse 1	Gear box 1	1
8	151273605-600.04.011.1	Kegelrad	Pinion	1
9	151273909-600.04.013.0	Deckel 2	Cover 2	1
10	154123503-627.04.008.0	Welle 1 sch.	Shaft	1
11	151301200-601.01.082.0	Deckel	Cover	1
12	151012601-510.03.041.0	Ölschraube	Tap	1
13	151274301-600.04.018.0	Dichtungsunterlage 1	Washer 1	1
14	151274409-600.04.019.0	Dichtungsunterlage 2	Washer 2	1
15	151274506-600.04.020.0	Dichtungsunterlage 3	Washer 3	1
16	151550609-603.04.029.0	Zahnrad 6-15/3	Gear 6-15/3	1
17	153176815-619.04.021.1	Zahnrad 75/3 zav.	Gear 2 75/3 var.	1
18	151550501-603.04.028.0	Gehäuse	Housing	2
19	151272606-600.04.007.1	Kettenrad 3-19,05/14	Sptocket 3-19,05/14	1
20	154125306-627.04.051.0	Welle 2 zav.	Shaft 2 var.	1
21	154116101-627.05.016.0	Lagergehäuse	Bearing housing	1
22	151280205-600.04.053.0	Kettenspanner	Tensioner 25,4/11	1
23	151280107-600.04.052.0	Bolzen	Bolt 18	1
24	151551618-603.04.025.1	Kettenrad sch. 25,4/14 zav.	Sprocket 2-25,4/14	1
25	151550100-603.04.012.0	Deckel links 1	Cover 1.	1
26	151273400-600.04.010.1	Kegel rad 3 3	Pinion 3	1
27	151300407-601.01.096.0	Stutzlager	Bearing	1
28	000244202	Lager KR 6007 2 Z	Bearing KR 6007 2 Z	1
29	000236300	Sicherungsring 62	Circlip N62	1
30	000237602	Sicherungsring 35	Circlip Z35	9
31	000208509	Schraube M8x15 8.8 Zn	Screw M8x15 8.8 Zn	2
32	150049307	Schraube M8x50 8.8 Zn	Screw M8x50 8.8 Zn	2
33	150106806	Schraube M10x20 8.8 Zn	Screw M10x20 8.8	2
34	000246601	Schmiernipl A M8x1	Lubricator A M8x1	3
35	000228202	Federunterlage B8 Zn	Washer B8 Zn	4
36	000228408	Federunterlage B10 Zn	Washer B10 Zn	2
37	000228603	Federunterlage B12	Washer B12	2
38	150032100	Wellendichtung 35x50x10	Oil seal 35x50x10	2
39	000245103	Lager 60 BC 10	Bearing KR 6012	1
40	000244104	Lager 35 BC 10	Bearing KR 6007	1
41	000210701	Schraube M10x 30 8.8 Zn	Screw M10x30 8.8 Zn	3
42	150106806	Schraube M10x20	Screw M10x20 8.8 Zn	4
43	000231109	Passfeder A 10x8x45	Key A 10x8x45	1
44	000228300	Unterlage B10	Washer B10	11
45	000210300	Schraube M10x25 8.8 Zn	Screw M10x25 8.8 Zn	8
46	150064600	Lager KR 6207 Z	Bearing KR 6207 Z	4
47	000254101	Schraube M10x25	Screw M10x25 8.8 Zn	8
48	000228300	Federunterlage B10	Washer B10	12
49	000237407	Sicherungsring 25	Circlip Z 25	1
50	000236505	Sicherungsring 72	Circlip N72	3
51	000246503	Schmiernipl A M6	Lubricator A M6	2
52	000256305	Passfeder A 10x8x60	Key A 10x8x60	1
53	150406000	Lager 35 BC 02 XPP	Bearing KR 6207 2 Z	1
54	150081002	Schraube M8x25 8.8 Zn K9	Screw M8x25 8.8 Zn	1
55	000220601	Mutter M8 5	Nut M8 5	1
56	000222609	Mutter M16	Nut M16	1
57	000228701	Unterlage B16	Washer B16	1
58	000224803	Unterlage A16	Washer A16	1
59	000244603	Lager 40 BC 10 XPP	Bearing KR 6008 2 Z	2
60	000237808	Sicherungsring 40	Circlip 40	1
61	150032208	Wellendichtung 40x72x10	Oil seal 40x72x10	1
62	150033109	Kette 2x19,05x11,68x13	Chain 2x19,05x11,68x13	3
63	150033207	Gelenk A-2x19,05x11,68	Lockin link A-2x19,05x11,68	3
64	151159908-TN01	Unterlage 8,5/24-1,5 Zn	Washer 8,5/24-1,5 Zn	4

Bild 1 Fig 1

Bild 1 Fig 1

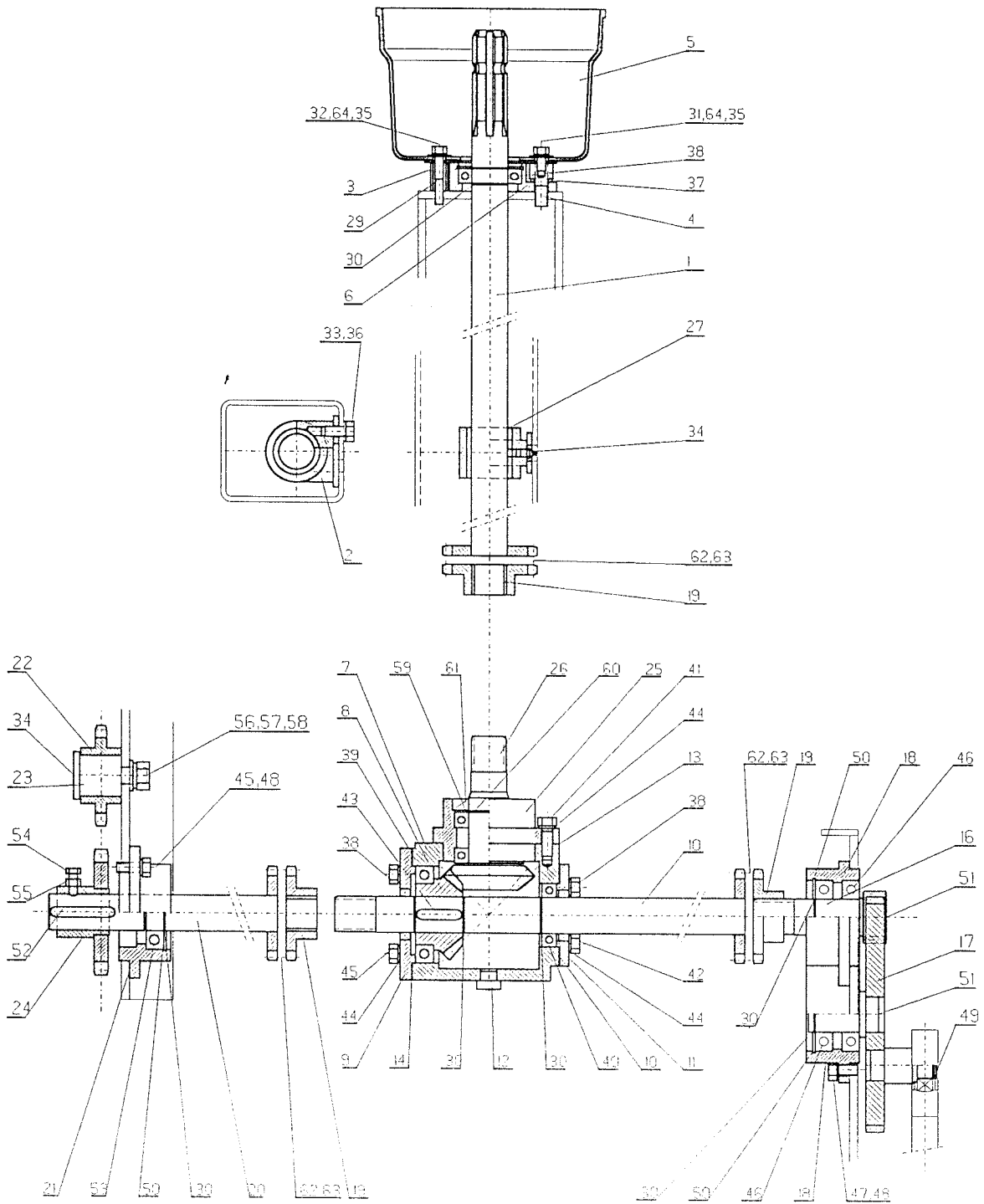

Numer anzeichn. No. on the figure	Katalog nummer Catalogue no.	Benennung	Description	Stück Quantity
1	154009600-627.04.045.0	Klinkenrad Ø40 zav.	Wheel Ø 40	1
2	154124209-627.04.032.0	Bedienumhebel links schw.	Handle 1	1
3	154124502-627.04.035.0	Kunststoffbuchse	Sleeve	2
4	154124708-627.04.037.0	Bedienungshebel recht.schw.	Handle	1
5	154125100-627.04.041.0	Pandel stange schw.	Bar	1
6	150107501-464.11.200.0	Lager KR S 205-2RS	Bearing KR S 205-2RS	1
7	900018901-K28.04.3.17.5	Lagerbuchse 25/30	Sleeve 25/30	1
8	153656608-619.04.042.0	Kulisse	Curve plate	1
9	900018705-K28.04.3.19.5	Bolzen	Bolt	2
10	153255907-619.04.046.0	Bolzen 18	Bolt 18	1
11	154127901-627.04.025.0	Klinker links	Locker	1
12	154128009-627.04.026.0	Klinker recht	Locker	1
13	153196106-619.04.041.0	Feder 2	Spring 2	1
14	154125501-627.04.062.0	Hebel schw.	Lever	1
15	154126109-627.04.068.0	Hebel schw.	Handle	1
16	154126305-627.04.070.0	Rohr 2	Tube 2	1
17	150413403-J BEVC	ZapfePVC 16 ZU	Tap PVC 16 Zu	1
18	150413305-(UN-T 558)	Schraube M10x25	Screw M10x25	1
19	910027802-V&N	Feder	Spring Zn	1
20	154126500-627.04.074.0	Positions platte	Position plate	1
21	154127000-627.04.079.0	Hebelträger	Plate	1
22	154131503-627.04.084.0	Hebel schw.	Bar	1
23	151233702-TN 01	Unterlage 20,5/36x2 Zn	Washer 20,5/36x2 Zn	1
24	154127402-627.085.086.0	Hebel schw.	Lever	1
25	153595906-619.04.054.0	Stange schw.	Bar	1
26	153327509-620.04.015.0	Stange schw.3	Bar 3	1
27	151749406-150.04.126.0	Bolzen	Bolt	1
28	151078005-TN 01	Unterlage 14,5/26-2 Zn	Washer 14,5/26-2 Zn	1
29	910027812-V&N	Feder Zn	Spring Zn	1
30	900019009-K.28.04.3.36.5	Feder	Spring	1
31	150288101	Mutter M22x1,5 8 Zn	Nut M22x1,5 8 Zn	6
32	000246503	Schmiernipl A M6	Lubricator A M6	4
33	000236809	Sicherungsring 16	Cirelip Z 16	2
34	150111408	Schraube M10x70 8.8 Zn	Screw M10x70 8.8 Zn	1
35	150084009	Mutter M10 8 Cd	Nut M10 8 Cd	1
36	000210300	Schraube M10x25 8.8 Zn	Screw M10x25 8.8 Zn	2
37	000228408	Sicherungsinterlage B10 Zn	Washer B10 Zn	2
38	150196004	SicherungsinterlageM12 8 Cd	Nut M12 8 Cd	1
39	000224304	Unterlage A 10 Zn	Washer A 10 Zn	1
40	150151007	Schraube M10x110 8.8 Zn	Screw M10x110 8.8 Zn	1
41	150084009	Mutter M10 8 Cd	Nut M10 8 Cd	1
42	150116305	Spannstift 8x30 Zn	Pin 8x30 Zn	1
43	150367800	Spannstift 6x32 Zn	Pin 6x32 Zn	1
44	150084704	Spannstift 5x32 Zn	Pin 5x32 Zn	1
45	000222100	Mutter M16	Nut M16	1
46	150230805	Mutter M16 leva 8 Zn	Nut M16 leva 8 Zn	1
48	151732904-150.01.022.0	Lagerbuchse 40/50-50	Sleeve 40/50-50	1
49	900018402-K28.04.3.24.5	Klinker	Locker	1
50	000237407	Sicherungsring 25	Cirelip Z 25	1
51	000237808	Sicherungsring 40	Cirelip Z 40	2
52	150064708	Passfeder A12x8x60	Key A12x8x60	1
53	159716104	Splint 4x20	Cotter 4x20	1
54	000212004	Schraube M12x30 8.8 Zn	Screw M12x30 8.8 Zn	4
55	000228505	Unterlage B12	Washer B12	4

Bild 2 Fig 2

Bild 2 Fig 2

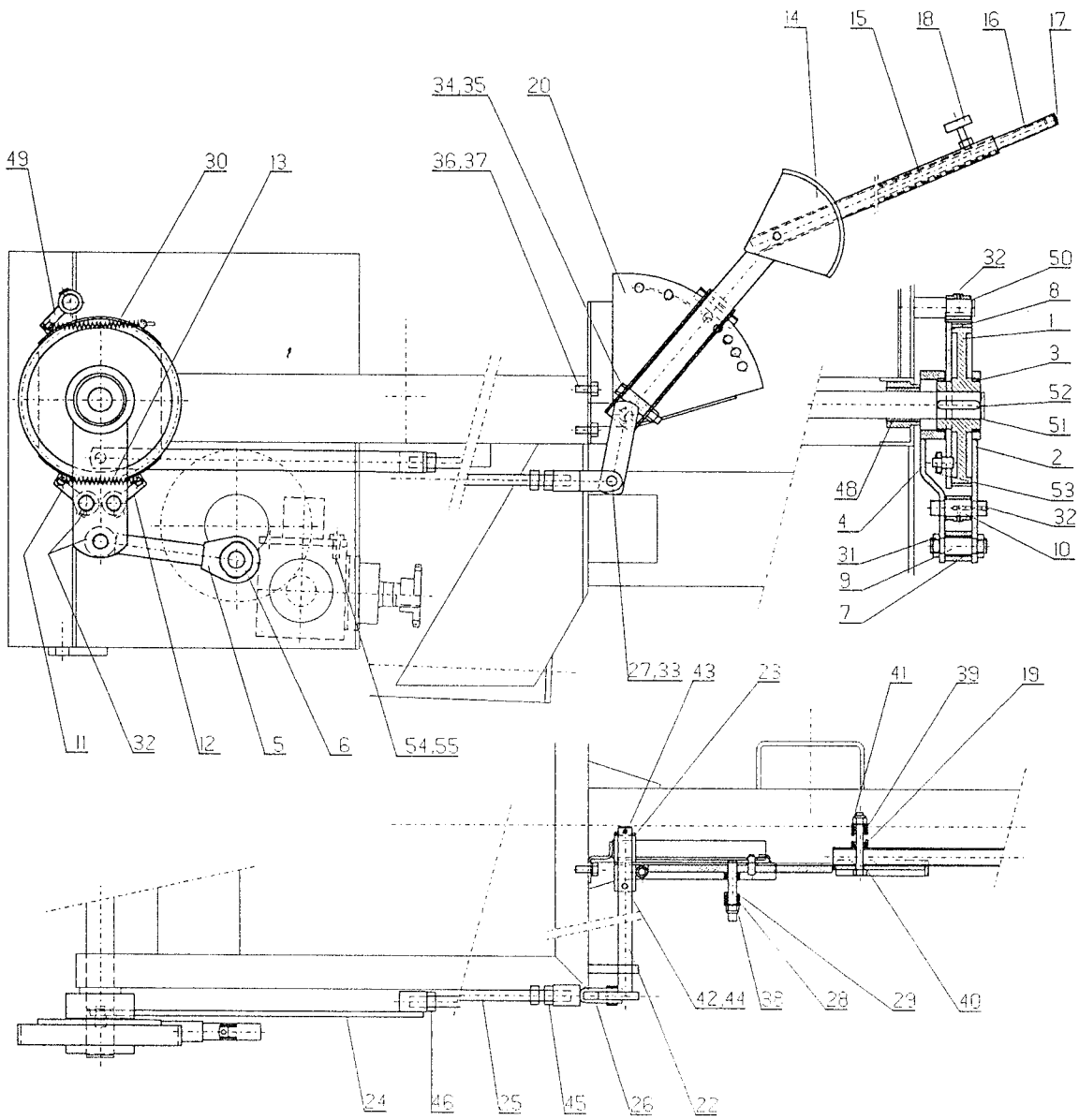

Numer anzeichn. No. on the figure	Katalog nummer Catalogue no.	Benennung	Description	Stück Quantity
1	000237808	Sicherungsring 40	Circlip	2
2	151269905-600.03.010.0	Kettennuss hinter	Rear cross chain wheel	2
3	000246601	Schmiernippl A M8x1	Lubricator	5
4	151549505-603.03.030.0	Lagerkonsole	Bracket	2
5	151732904-150.01.022.0	Buchse	Sleeve	2
6	151153502-166.810	Plate 40,2/65x2	Plate 40,2/65x2	2
7	000231305	Passfeder A 12x8x45	Key A 12x8x45	2
8	153184707-619.03.003.0	Welle	Shaft1	1
9	000250105	Schraube M10x50 4.6 Zn	Screw M10x50 4.6 Zn	14
10	153184815-619.03.005.1	Brett innen 1	Board inner 1	6
11	000231804	Spannstift	Pin 4x10	3
12	153185011-619.03.007.1	Brett innen 3	Board inner 3	1
13	150040306	Mutter M20 5 Zn	Nut M20 5 Zn	2
14	153332003-620.03.002.0	Stange schw.3	Bar 3	2
15	153332209-620.03.004.0	Bolzen schw. 1	Bolt 1	2
16	151641405-606.06.015.0	Kettennuss vorne	Front cross chain wheel	2
17	151641502-606.06.016.0	Lagerbuchse	Sleeve 30	2
18	000237504	Sicherungsring 30	Circlip Z 30	2
19	000221502	Mutter M12 5 Zn	Nut M12 5 Zn	6
20	000228603	Unterlage B12 Zn	Washer B 12 Zn	6
21	000212004	Schraube M12x30 8.8 Zn	Screw M12x30 8.8 Zn	6
22	000219604	Schraube M10x40 4.6 Zn	Screw M10x40 4.6 Zn	40
23	151180509-115.10.026.0	Gelenk	Louking link	2
24	151269416-600.03.006.1	Kette 237 d.	Chain 237 d.	2
25	151270902-600.03.004.0	Stahlprofil U-2	Profile U 2	20
26	151178102-115.10.024.5	Mutter 1	Nut 1	40
27	151177602-100.10.041.0	Blech	Plate	30
28	000251104	Mutter M10 4 Zn	Nut M10 4 Zn	44
29	000230100	Unterlage A10 Zn	Washer A10 Zn	84
30	151178004-100.10.043.1	Klammer	Clamp	40
31	150321404	Schraube M20x130 8.8 Zn	Screw M20x130 8.8 Zn	2
33	000219105	Schraube M10x55 4.6 Zn	Screw M10x55 4.6 Zn	30
34	154130201-627.03.051.0	Seitenblech recht	Right side plate	1
35	153185403-619.03.011.0	Schutzblech vorne	Middle protection	1
36	153184913-619.03.006.1	Brettinnen 2	Board inner 2	1
37	153185119-619.03.008.1	Brett recht	Board r.	1
38	153185217-619.03.009.1	Brett links	Board l.	1
39	154130309-627.03.052.0	Seitenblech links	Left side plate	1

Bild 3 Fig 3

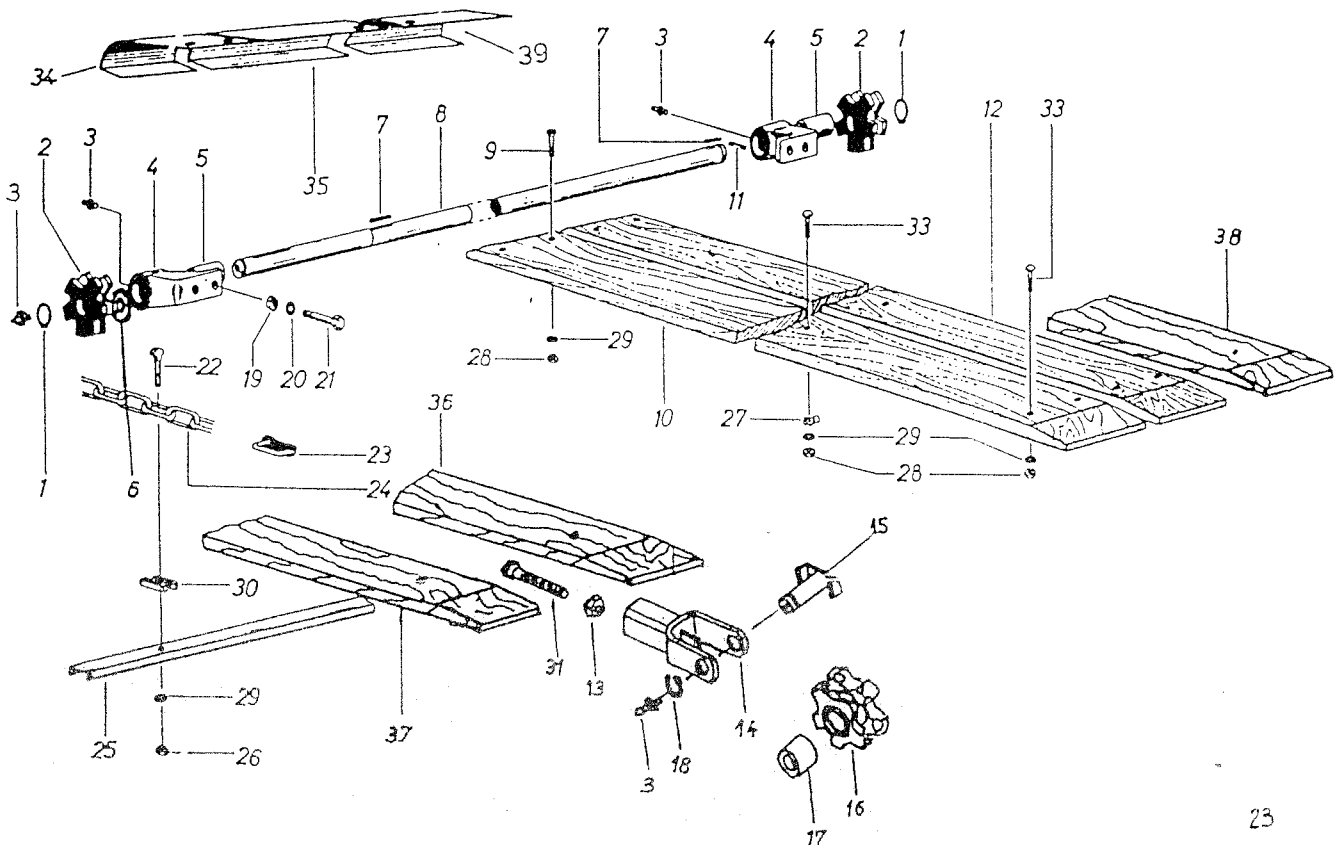

Numer anzeichn No.on the figure	Katalog number Catalogue no.	Benennung	Description	Stück Quantity
1	154132209-627.03.017.0	Spanner schw.	Tensioner	2
2	153332209-620.03.004.0	Bolzen I schw.	Bolt	2
3	151641405-606.06.015.0	Ketennus vorne	Cross chain wheel front	2
4	151641502-606.06.016.0	Lagerbuchse 30/40-48	Sleeve	2
5	154132307-627.03.025.0	Distanzapfen	Tap	2
6	154128900-627.03.019.0	Stränge links schw.	Bar.l.	1
7	154129106-627.03.021.0	Führungsrohr schw.	Tube	1
8	154129400-627.03.026.0	Hebl schw.	Lever	2
9	154132405-627.03.029.0	Stange recht schw.	Bar d.	1
10	154129605-627.03.031.0	Rohrmutt M20 schw.	Nut M20	1
11	154129801-627.03.034.0	Segment	Segment	1
12	154134207-627.03.036.0	Bolzen 10	Bolt 10	1
13	154129909-627.03.037.0	Bolzen 10	Bolt 10	2
14	151749406-150.04.126.0	Bolzen	Bolt	2
15	152526207-453.06.046.0	Feder 1	Spring 1	1
16	154130005-627.03.039.0	Feder 1	Spring 1	1
17	153446300-374.00.016.0	Unterlage 22/50	Washer 22/50	1
18	000237504	Sicherungsring 30	Circlip Z 30	2
19	000246601	Schmiemipl A M8x1	Lubricator A M8x1	2
20	000236809	Sicherungsring 16	Circlip Z 16	4
21	000237103	Sicherungsring 20	Circlip Z 20	2
22	000237407	Sicherungsring 25	Circlip Z 25	4
23	000228809	Unterlage B 20	Washer B20	1
24	000222208	Mutter M20	Nut M20 8 Zn	2

Slika 4

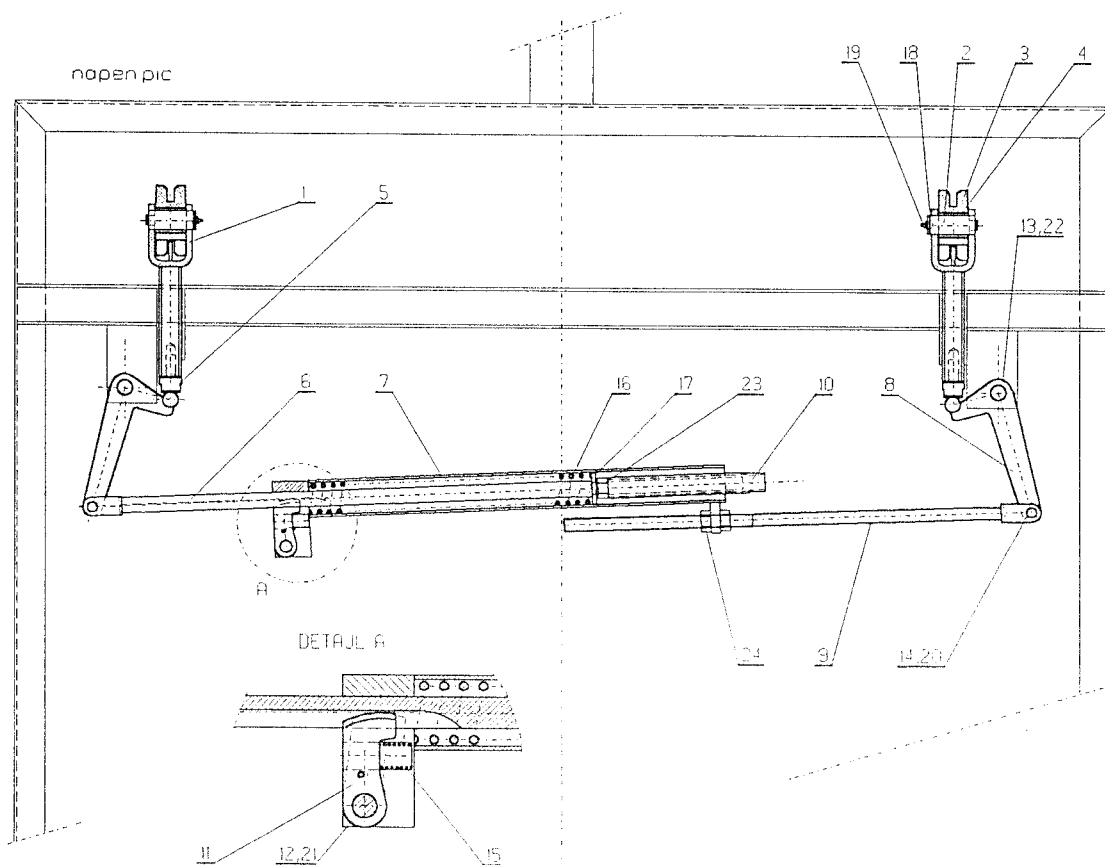

Numer anzeichn. No.on the figure	Katalog nummer Catalogue no.	Benennung	Description	Stück Quantity
-	154122602-627.05.000.0	Strenvorrichtung	Spring device	1
1	154122700-627.05.001.0	Rahmen	Frame	1
2	154118001-627.05.012.0	Profil mit den Platten	Profile	1
3	154115905-627.05.014.0	Welle	Shaft	1
4	151555604-603.05.063.0	Gehäuse	Housing	4
5	151320207-601.09.081.1	Kegelrad 1-19/4,4	Pinion 1-19/4,4	8
6	154116003-627.05.015.0	Profil HOP UPS 2	Profile HOP UPS 2	1
7	154116101-627.05.016.0	Lager gehäuse	Bearing housing	1
8	151555203-603.05.057.0	Gehäuse 2	Housing 2	4
9	151555311-603.05.058.1	Welle 11	Shaft 11	4
10	151321206-601.09.093.0	Buchse	Sleeve	4
11	151551618-603.04.025.1	Kettenrad	Sprocket	1
12	151283701-600.05.023.1	Gehäusedeckel	Housing cover	5
13	151558200-601.09.102.0	Platte 3	Plate 3	4
14	151558308-601.09.103.0	Platte 3	Plate 3	4
15	151321304-601.09.095.0	Platte 3	Plate 3	4
16	154117805-627.05.021.0	Streuzgylinder recht schw.	Spreading cylinder	2
17	154121907-627.05.025.0	Segment	Segment	32
18	151283505-600.05.022.1	Lagergehäuse	Bearing housing	4
19	154117903-627.05.029.0	Streuerzylinder links schw.	Spreading cylinder	2
20	154116502-627.05.041.0	Bolzen 19	Bolt 19	2
21	154123004-627.05.042.0	Eksc.Bedinungshebel Zn	Handle Zn	2
22	154152204-627.05.072.0	Band 2	Band 2	1
23	154152302-627.05.073.0	Gummiband	Rubber band	1
24	000204807	Schraube M12x150 8.8 Zn	Screw M12x150 8.8 Zn	8
25	000254101	Schraube M8x25 8.8 Zn	Screw M8x25 8.8 Zn	2
26	000250800	Sicherungsmutter M8 5 Cd	Nut M8 5 Cd	11
27	150160300	Mutter M12 8 Zn	Nut M12 8 Zn	8
28	000224402	Unterlage A12	Washer A12	8
29	000228505	Unterlage B12	Washer B12	8
30	000246601	Schmiermipel A M8x1	Lubricator A M8x1	8
31	150129104	Kette 1x25,4x17,02x53	Chain 1x25,4x17,02x53	1
32	150034108	Gelenk B-1x25,4x17,02	Locking link B-1x25,4x17,02	1
33	159439609	Schraube M8x25	Screw M8x25	9
34	150108804	Schraube M10x25 Zn	Screw M10x25 Zn	98
35	150084009	Sicherungsmutter M10 8 Cd	Nut M10 8 Cd	98
36	000231109	Passfeder A 10x8x45	Key A 10x8x45	8
37	000237602	Sicherungsring 35	Circlip Z 35	10
38	150033902	Schraube M8x25 8.8 Zn	Screw M8x25 8.8 Zn	1
39	000210300	Schraube M10x25 8.8 Zn	Screw M10x25 8.8 Zn	8
40	000210202	Schraube M10x25 8.8	Screw M10x25 8.8	20
41	000220905	Mutter M8 8 Zn	Nut M8 8 Zn	1
42	000228300	Sicherungsunterlage B10	Washer B10	28
43	000225802	Unterlage C10	Washer C10	8
44	150130806	Passfeder A 10x8x55	Key A10x8x55	1
45	150406000	Lager KR 6207 2RS	Bearing KR 6207 2RS	1
46	000236505	Sicherungsring U 72	Circlip N 72	1
47	000245005	Lager KR 6210 2 Z	Bearing KR 6210 2 Z	4
48	000244006	Lager KR 6207 2 Z	Bearing KR 6207 2 Z	4
49	150065002	Lager KR 6010 2 Z	Bearing KR 6010 2 Z	4
50	150036400	Wellendichtung 45x72x10	Oil seal 45x72x10	4
51	150033608	Lager KR 1206	Bearing KR 1206	4
52	150006102	Wellendichtung 40x62x10	Oil seal 40x62x10	4
53	150084401	Unterlage C8 Zn	Washer C8 Zn	1
54	000228202	Unterlage B8 Zn	Washer B8 Zn	1
55	000248903	Schraube M8x20 8.8 Zn	Screw M8x20 8.8 Zn	1

Bild 5 Fig 5

Bild 5 Fig 5

vtn4 pic

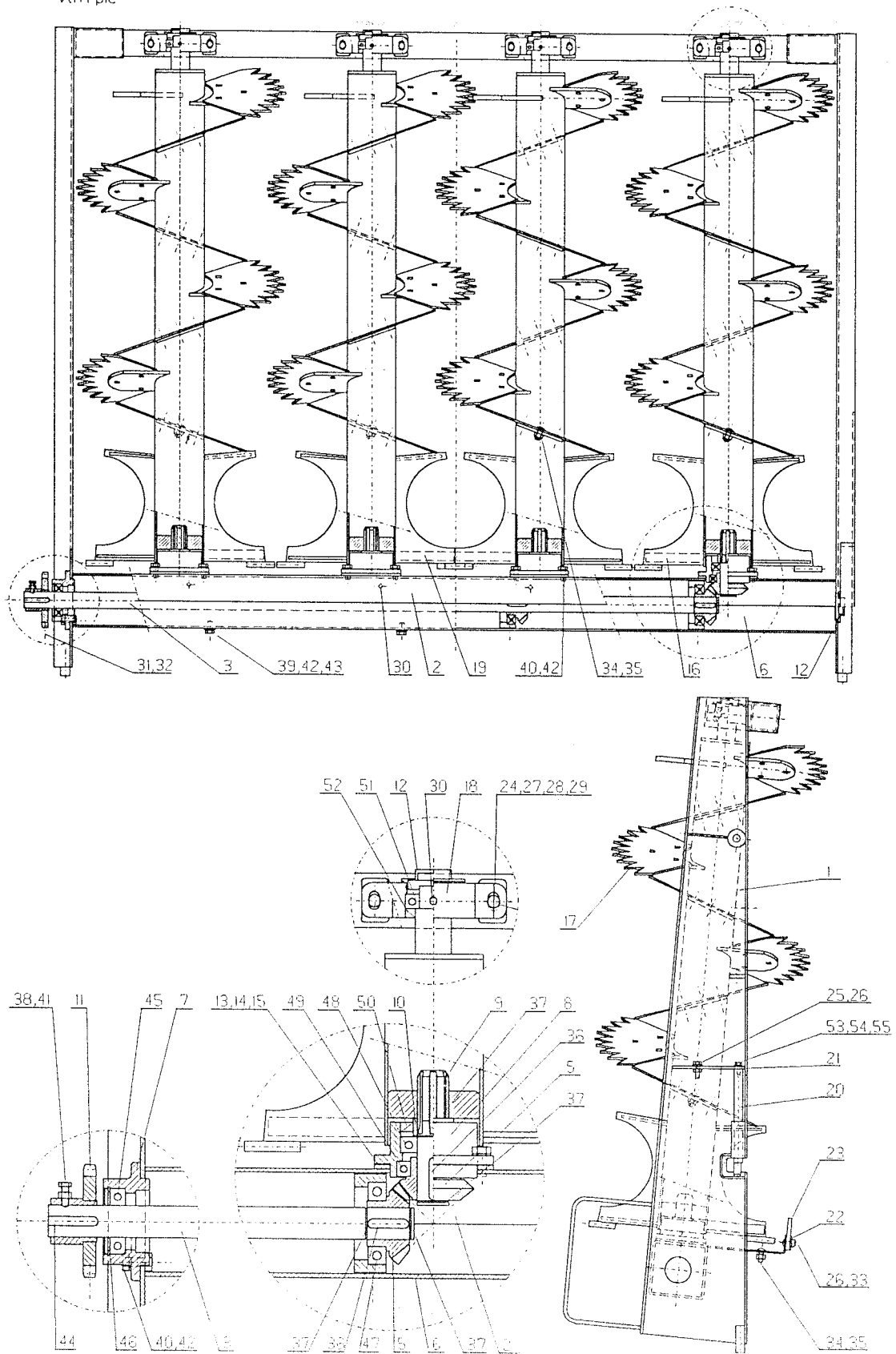

Numer anzechn. No.on the figure	Katalog nummer Catalogue no.	Benennung	Description	Stück Quantity
1	154137605-627.08.001.0	Schutz schw.	Protection	1
2	154139104-627.08.020.0	Buchse	Sleeve 4	2
3	154137302-627.08.030.0	Zylinder 25/195	Cylinder 25/195	1
4	152290504-TN 01	Unterlage 16,5/34 Zn	Washer 16,5/34 Zn	2
5	154143206-627.15.001.0	Hydraulischer Rohr	Hydraulic hose	1
6	151684706-330.03.010.0	Träger	Holder	8
7	151345208-651.03.003.0	Getriebe 22/20	Reductor 22/20	2
8	151936908-120.52.002.0	Anschluss	Connection	1
9	150050401-	Anschluss 12 FS1.0746	Conection 12 FS1.0746	1
10	150415802	Rohr 1 ST NP8-800	Tube 1 ST NP8-800	1
11	150415704	Rohr 1 ST NP8-650	Tube 1 ST NP8-650	1
12	150108403	Klemmer AMD M22x1,5	Clamp AMD M22x1,5	2
13	150108500	Klemmer AŽD M22x1,5	Clamp AMD M22x1,5	1
14	150107805	Schlies pfeife	Tap	1
15	150038006	Mutter 1 M20x1,5 Zn	Nut	2
16	150038104	Dichtungsring	Oil seal	2
17	000252906	Unterlage A 22x27	Washer A 22x27	3
18	150124305	Unterlage 20x26	Washer 20x26	1
19	000250800	Mutter M8 5 Cd	Nut M8	8
20	150202104	Unterlage 16 Zn	Washer 16	2
21	000253807	Schraube M16x40 8.8 Zn	Screw M16x40 8.8 Zn	2
22	000251505	Sicherungsring B16 Zn	Washer B16 Zn	2
23	000239209	Splint 4x32 Zn	Cotter 4x32 Zn	2

Bild 6 Fig 6

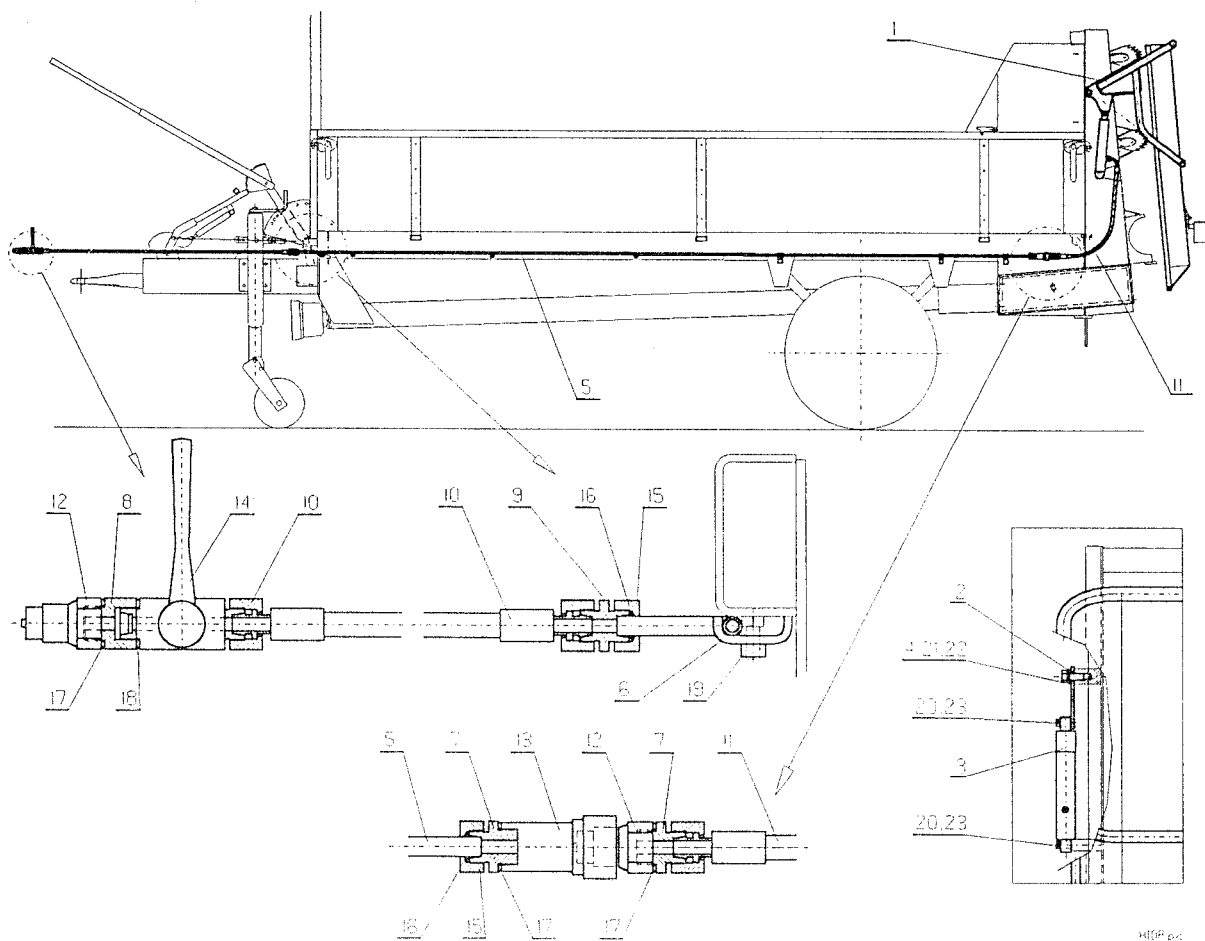

Numer anzechn. No.on the figure	Katalog nummer Catalogue no.	Benennung	Description	Stück Quantity
1	154136606-627.13.002.0	Beleuditungsträger schw.	Light holder	1
2	154136900-627.13.008.0	Gummiträger	Ruber holder	1
3	154137008-627.13.010.0	Träger 2 schw.	Holder	2
4	151322900-250.00.002.0	Spanstift R 3	Pin	2
5	150218302	Schraube M6x30 8.8 Zn	Screw M6x30 8.8 Zn	2
6	150030709-F.ASPOCK	Stift 7-polni	Plug	1
7	150132706-F.ASPOCK	Rückstralher-wies D80	Reflector D80 - beli	2
8	150298500-F.ASPOCK	Lampe kpl.2002	Lamp kpl.2002	2
9	150298608-F.ASPOCK	Lampe-stecker 2032	Lamp switch 2032	1
10	150132608	Rückstrahler D80 - orange	Leflector D80	2
11	150132706	Rückstrahler weis	Leflector	2
12	151492600	Träger	Holder	15
13	150298706-F.ASPOCK	Glübirne 6010 (12V;5W)	Electric bulb 6010 (12V;5W)	2
14	150031307- F.ASPOCK	Glübirne (12V;21W)	Electric bulb (12V;21W)	4
15	000210701	Schraube M10x30 8.8 Zn	Screw M10x30 8.8 Zn	2
16	000250702	Mutter M10 5 Cd	Nut M10 5 Cd	2
17	000225900	Unterlage C10 Zn	Washer C10 Zn	2
18	000254101	Schraube M8x25 8.8 Zn	Screw M8x25 8.8 Zn	2
19	000250800	Mutter M8 5 Cd	Nut M10 5 Cd	2
20	150084401	Unterlage C8 Zn	Washer C8 Zn	4
21	150298902-F.ASPOCK	Steckez kpl. 3204	Plug 3204	2
22	150298804-F.ASPOCK	Steckez kpl.3200	Plug .3200	1
23	000251300	Unterlage A16 Zn	Washer A 16 Zn	2
24	000215109	Schraube M5x20 4.6 Zn	Screw M5x20 4.6 Zn	2
25	150047602	Unterlage C5 Zn	Washer C5 Zn	2
26	150029604	Mutter M5	Nut M5	2
27	150417702-F. ASPOECK	Kabel (4x0,75x2500)	Cable (4x0,75x2500)	1
28	150417800-F. ASPOECK	Kabel (4x0,75x4000)	Cable (4x0,75x4000)	1
29	150417908-F. ASPOECK	Kabel (4x0,75x6000)	Cable (4x0,75x6000)	1

Bild 7 Fig 7

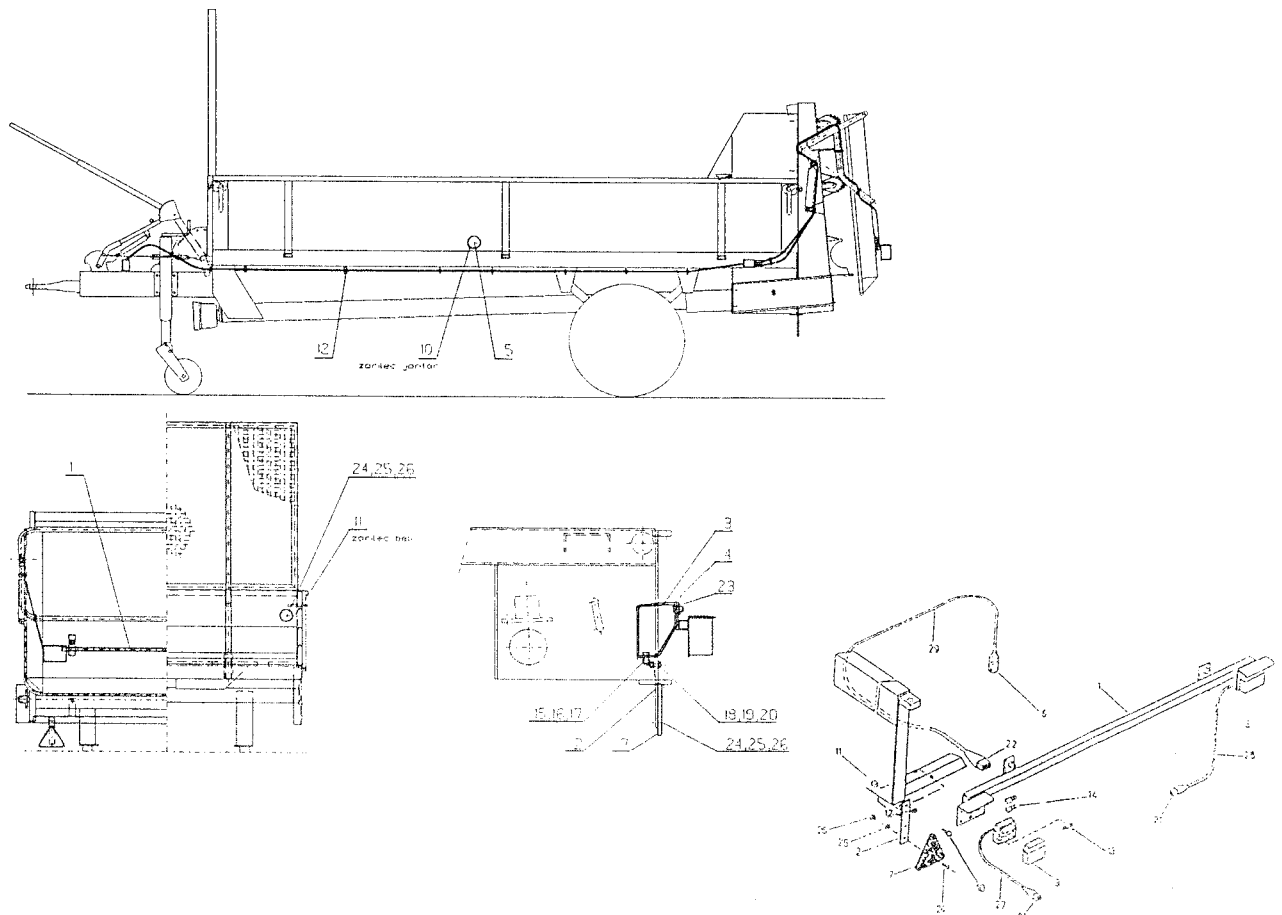

Numer anzeihn. No.on the figure	Katalog nummer Catalogue no.	Benennung	Description	Stück Quantity
1	154120301-627.07.001.0	Seitenwand vorne schw.	Front side	1
2	154120604-627.07.007.0	Seiten wandrahmen recht schw.	Right side frame	1
3	154119206-627.07.016.0	Brett 1	Board 1	2
4	154119304-627.07.017.0	Brett 2	Board 2	3
5	154119402-627.07.018.0	Brett 3	Board 3	1
6	154119509-627.07.019.0	Brett 4	Board 4	1
7	154119607-627.07.026.0	Seitenwandrahmen links	Left side frame	1
8	150412707-PRILLINGER	Bedienungshebl recht R 6121/N-350365	Handle r. R 6121/N-350365	2
9	150412805-PRILLINGER	Bedienungshebl links L.6121/N-350366	Handle l.6121/N-350366	2
10	154119803-627.07.028.0	Brett5	Board 5	1
11	154120908-627.07.040.0	Seitenwand hinten schw.	Rear side	1
12	154120800-627.07.030.0	Siebschutz schw.	Protection	1
13	150413207	Schraube links 6x30 Zn	Screw 6x30 Zn	18
14	150413207	Schraube links 6x30 4.6 Zn	Screw 4.6 Zn	18
15	000220905	Mutter M8 Zn	Nut M8	14
16	000228202	Sicherungsunterlage B8 Zn	Washer B8	14
17	150065100	Schraube M12x75 8.8 Zn	Screw M12x75 5.6 Zn	6
18	000250604	Mutter M12 5 Cd	Nut M12	6
19	151075801-115.00.002.5- A	Keil	Wedge	2
20	151140401-100.03.023.0 -A	Gumitragspanner	Tensioner	2
21	151140508-100.03.022.0 -A	Befestigungsplatte	Plate	2
22	150019107-A	Niet A5x16	Rivet A5x16	4

A= ORION 40 R-PRO

Bild 8 Fig 8

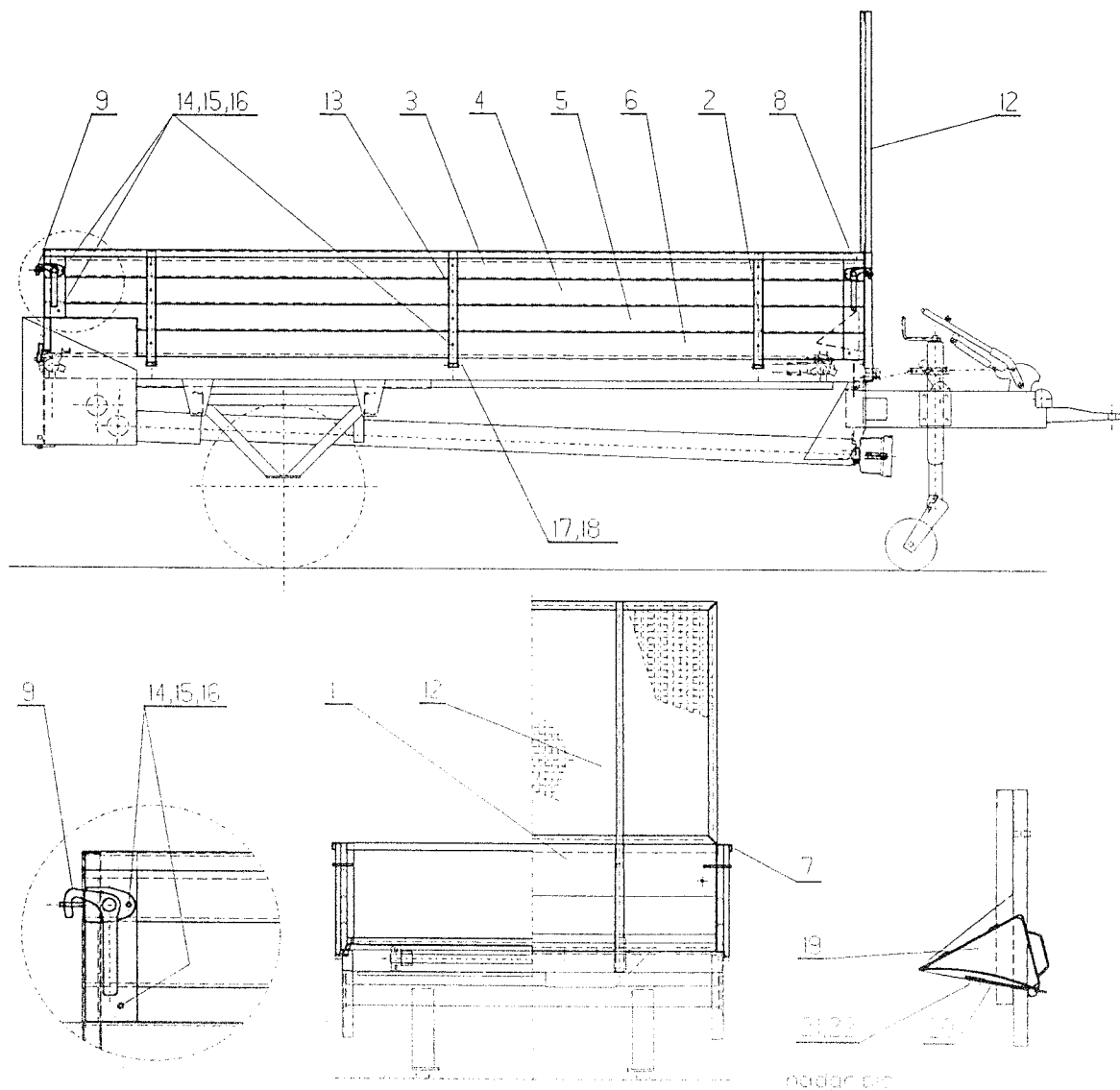

Numer anzechn. No.on the figure	Katalog nummer Catalogue no.	Benennung	Description	Stück Quantity
1	154139300-627.12.001.0	Betriebschutz I schw.	Drive protection	1
2	154139907-627.12.010.0	Schutz 3	Protection 3	1
3	154140003-627.12.012.0	Schutz 5	Protection 5	1
4	154140101-627.12.015.0	Stange	Bar	1
5	154140209-627.12.020.0	Kettenschutz schw.	Chain protection	1
6	154141002-627.12.045.0	Seitenblech links	Side tin plate l.	1
7	154141100-627.12.047.0	Stift	Pin	2
8	154141306-627.12.049.0	Seitenblech recit	Side tin plate r.	1
9	154141404-627.12.050.0	Wellenschutz rechts schw.	Shaft protection	2
10	154141707-627.12.054.0	Wellenschutz links schw.	Shaft protection	2
11	154141805-627.12.057.0	Träger	Holder	1
12	150388609	Schraube M6x12 Zn	Screw M6x12 D-E-35639	16
13	150106806	Schraube M10x20 8.8 Zn	Screw M10x20	10
14	150084009	Mutter M10 8 Cd	Nut M10 8 Cd	6
15	000224304	Unterlage A10 (10,5/21-2) Zn	Washer A 10 (10,5/21-2) Zn	12
16	150414509	Schraube M10x30 UN T568 (ULMER)	Screw M10x30 UN T568	2

Bild 9 Fig 9

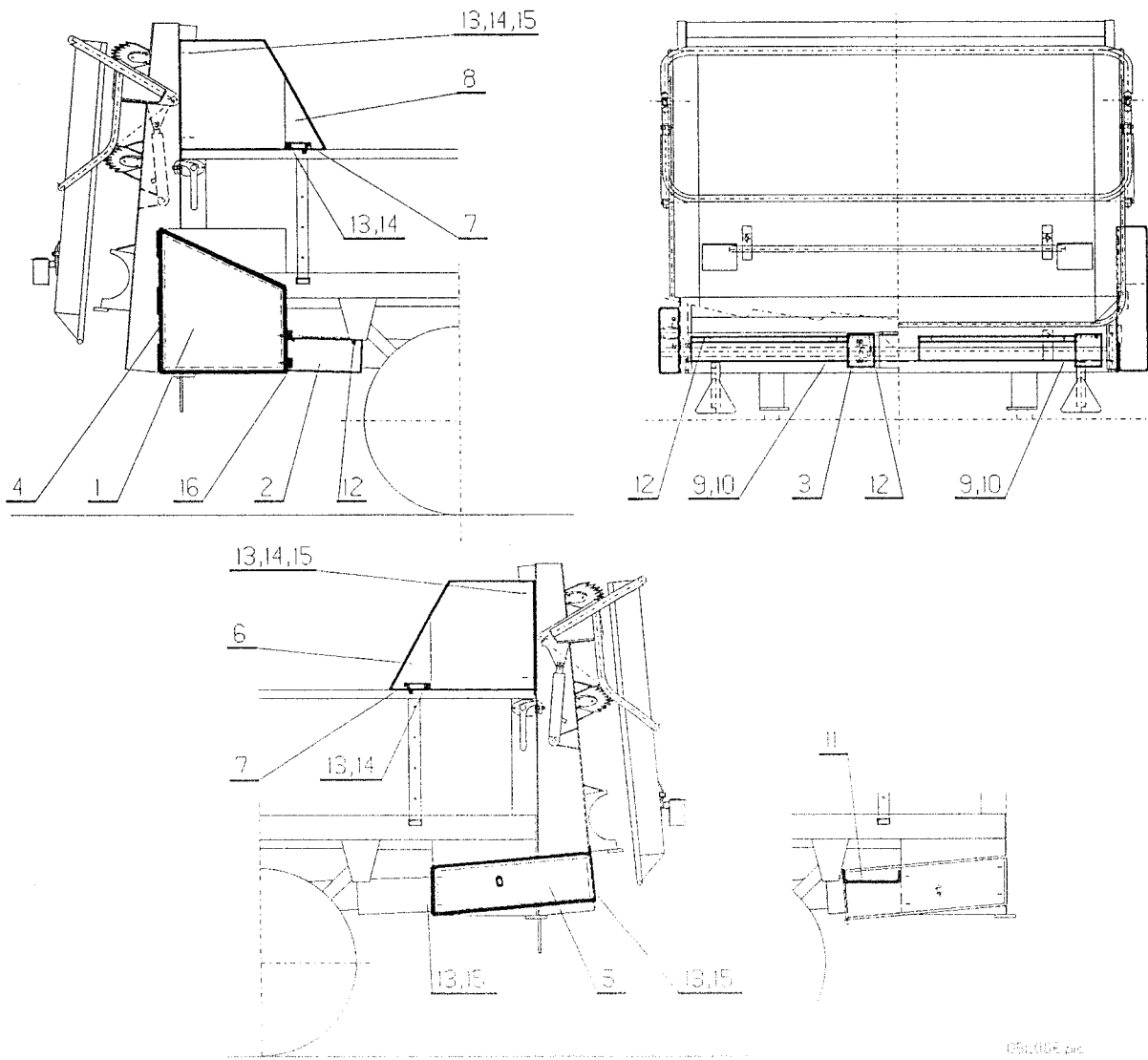

05/10/05 doc

Numer anzechn. No.on the figure	Katalog nummer Catalogue no.	Benennung	Description	Stück Quantity
-	153969307-163.02.010.0	Achse schw.	Souare axle	1
16	150040208	Mutter M16 8 Zn	Nut M16 8 Zn	16
18	150144506	Schlauch 11,5/80 15 ven 16	Pneumatics 11,5/80	2
18	150414705	Schlauch 15.0/55 x17	Pneumatics 15.0/55x17	2
24	000205502	Schraube M16x50 8.8 Zn	Screw M16x50 8.8 Zn	8
28	153404006-619.02.018.0	Felge 1-9.00x15,3	Rim 9.00x15,3	2
28	150416801	Felge 13.00x17	Rim 13.00x17	2
29	150118401	Reifen 11.5/80-15 10 Ply	Tyre 11.5/80-15 10 Ply	2
29	150414607	Reifen 15.0/55x17	Tyre 15.0/55x17	2

Bild 10 Fig 10

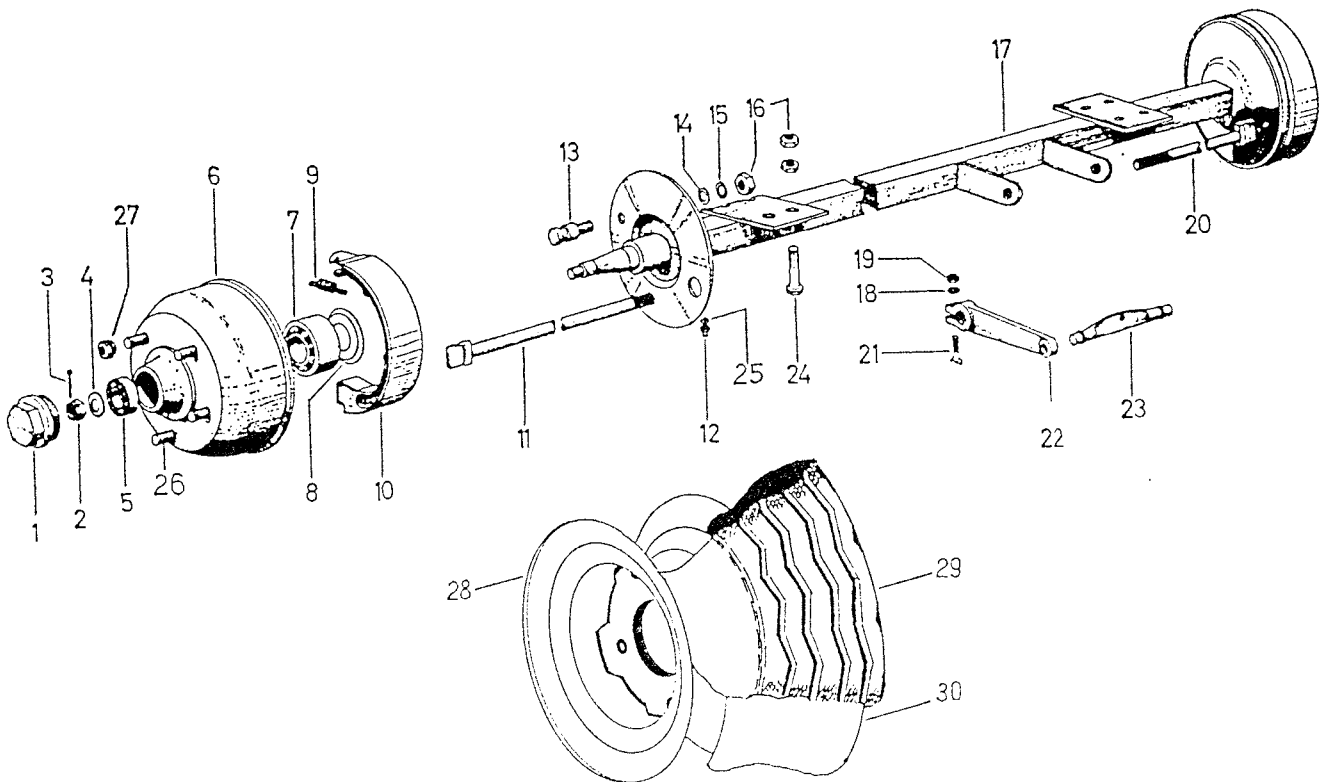

Numer anzeihn. No.on the figure	Katalóg nummer Catalogue no.	Benennung	Description	Stück Quantity
1	930RRM8A/01	Gehäuse kpl.	Housing	1
2	930RRM8A/02	Zustange kpl.	Bar	1
3	930RRM8/A03	Enablech	Tin plate	1
15	930RRM8/A15	Bolzen	Bolt	1
16	930RRM8/A16	Zylinder hinten	Rear cylinder	1
17	930RRM8/A17	Bolzen	Bolt	1
18	930RRM8/A18	Zylinder vorne	Front cylinder	1
19	930RRM8/A19	Dämpfer	Shock absorber	1
20	930RRM8/A20	Blockade den Zugstange	Locker	1
21	930RRM8/A21	Spannstift	Pin	1
22	930RRM8/A22S	Bremshobl hinten	Brake lever rear	1
23	930RRM8/A23S	Spannstift	Pin	1
24	930RRM8/A24	Bolzen	Bolt	2
25	930RRM8/A25	Hebe	Lever	2
26	930RRM8/A26	Buchse	Sleeve	3
27	930RRM8/A27	Drathseil	Rope	2
28	930RRM8/A28 - 455604306	Bremshandhebe	Hand brake lever	1
29	930RRM8/A29	Schutz vorne	Front protection	1
30	930RRM8/A30	Buchse	Sleeve	1
31	930RRM8A/31	Nadelager	Ball-bearing	2
32	930RRM8A/32	Innenring	Inner ring	2
33	930RRM8A/33	Dichtung	Oil seal	2
34	930RRM8A/34	Lager	Ball-bearing	2
35	930RRM8A/35	Wellendichtung	Oil seal	2
37	930RRM8A/37	Kunststafzapfen	Plastic tap	2
38	930RRM8A/38	Mutter	Nut	5
39	930RRM8A/39	Sicherungs Unterlage	Washer	2
40	930RRM8A/40	Schraube	Screw	2
41	930RRM8A/41	Schraube	Screw	2
42	930RRM8A/42	Sicherungs Unterlage	Washer	2
43	930RRM8A/43	Schraube	Screw	1
44	930RRMA/44	Sicherungs Unterlage	Washer	5
45	930RRM8A/45	Stift	Pin	4
46	930RRM8A/46	Schraube	Screw	1
47	930RRM8A/47	Schraube	Screw	2
48	930RRM8A/48	Sicherungs Unterlage	Washer	1
49	930RRM8A/49	Schraube	Screw	1
50	930RRM8A/50	Gabeln	Fork	1
51	930RRM8A/51	Pneumatischer Dämpfer	Pneumatic shock absorber	1
63	930RRM8A/63	Dämpfer	Shock absorber	1
64	914P118	Zugkopf	Tow head	1

Bild 11 Fig 11

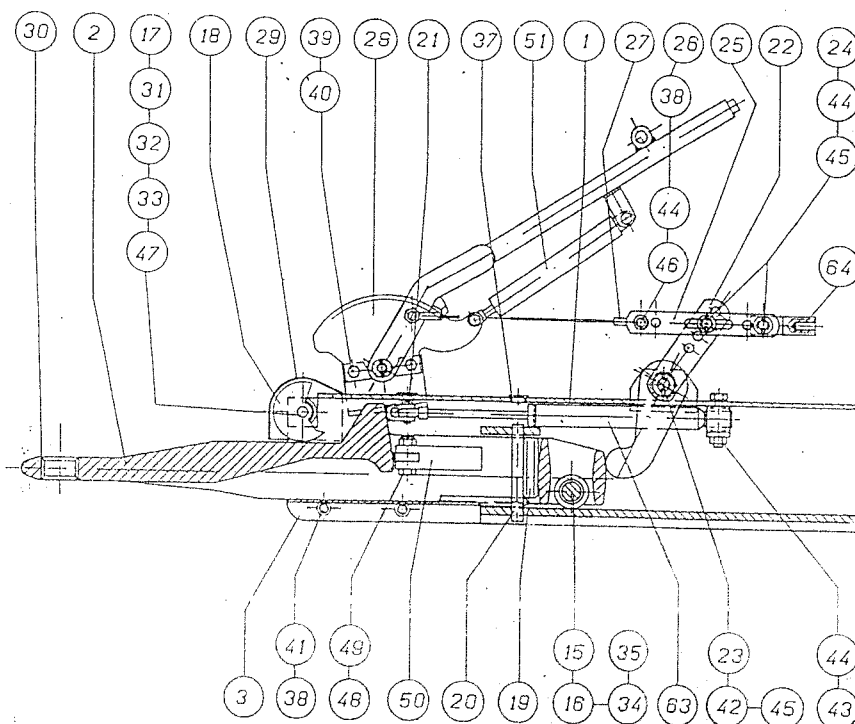

Numer anzechn. No.on the figure	Katalog nummer Catalogue no.	Benennung	Description	Stück Quantity
1	151304207-601.04.000.0	Anschlussstrebe	Hitch welded	1
2	151304706-601.04.010.0-op	Bewegliche Anschluss	Fkexible hitch	1
3	151075605-115.33.011.5	Bremshebe	Brake lever	1
4	151268700-600.11.001.0	Stahlstrick kpl.	Steel rope	1
4	154144107-627.00.010.0 - A	Drathstrick 5	Stel rope 5	1
5	151192202-115.33.007.5	Bremsl�rger kpl.	Brake holder	1
6	000206100	Schraube M16x75 8.8	Screew M16x75 8.8	2
7	000208901	Schraube M8x25 5.6	Screw M8x25 5.6	2
8	000221904	Mutter M16 5	Nut M16 5	2
9	000220601	Mutter M8 5	Nut	2
10	000228701	Unterlage B 16	Washer B16	2
11	000228104	Unterlage B8	Washer B8	2
12	150023307	Strickklammer	Clamp 6,5 Zn	2
12	150025001 - A	Strickklammer 6,5	Clamp	6
13	150025109	Locen A5	Handle A5	1
13	150025109 - A	Locen A5	Hande A5	2
14	000246601	Scniernipel A M8x1	Lubricator A M8x1	1

A = ORION 40R PRO
op = option

Bild 12 Fig 12

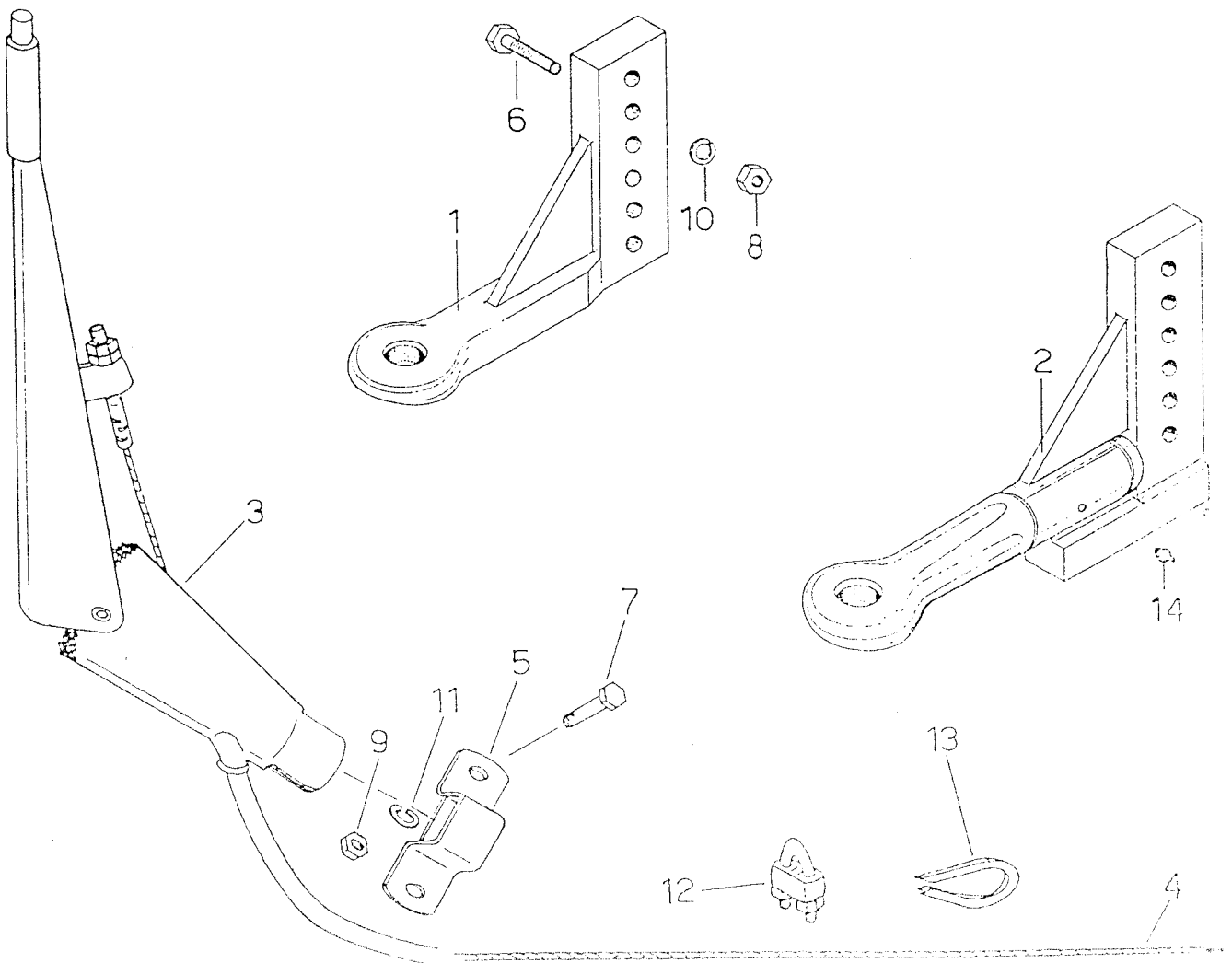

Numer anzechn. No.on the figure	Katalog nummer Catalogue no.	Benennung	Description	Stück Quantity
-	151268407-600.10.000.0	Stutzfus	Suport wheen	1
1	000241802	Niet 6x20	Rivet 6x20	1
2	151068604-11.23.048.5	Bedinungshebel	Handle	1
3	151068506-11.23.41a.6	Bolzen 13	Bolt 13	1
4	151069006-200.07.017.0	Platte	Plate	1
5	000246601	Schmiernipel A M8x1	Lubricator A M8x1	1
6	159447501	Schraube M14x30	Screw M14x30	4
7	000228907	Unterlage B14	Washer B14	4
8	000221806	Mutter M14 8	Nut M14 8	4
9	151268504-600.10.001.0	Führungsrohr	Tube	1
10	150013005	Kugl 8	Ball 8	14
11	151068702-11.23.030.7	Spindel	Splindle	1
12	000232607	Spannstift 5x32	Pin 5x32	2
13	151069505-11.23.050.8	Gleitrohr kpl.	Tube	1
14	151071100-11.23.046.7	Bolzen 14	Bolt 14	1
15	151027506-438.001	Drathsicherung 4	Wire safety clamp 4	1
16	151070600-215.03.007.7	Rad kpl.	Wheel	1
17	151071306-11.23.047.6	Bolzen 5	Bolt 5	1
18	000240705	Splint 6,3x40	Cotter 6,3x40	2

Bild 13 Fig 13

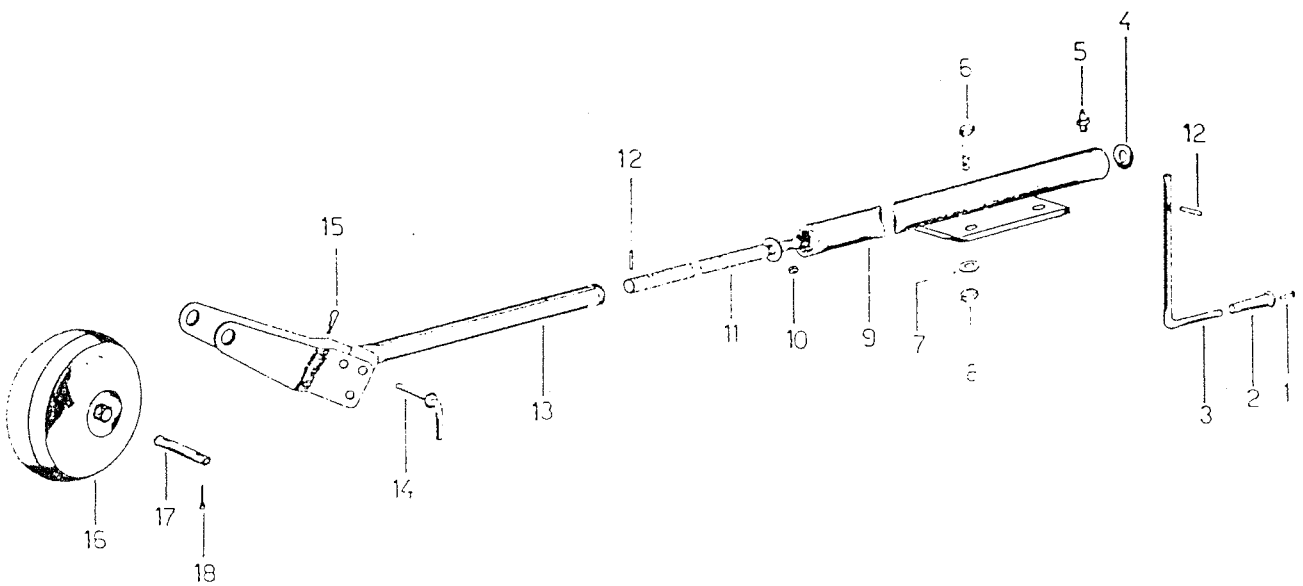

Gelenkwellenbauformen

PTO drive shaft designs

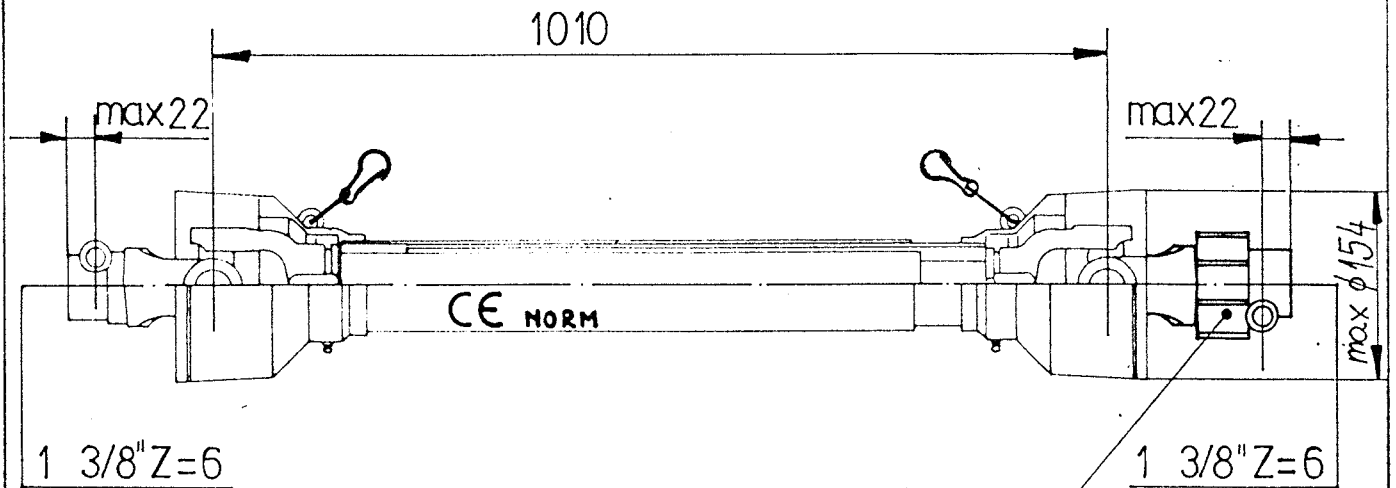

STERNRATCHE
RADIAL PIN CLUTCH R RECHTS
RIGHT

Moment 900 Nm

Bestelltext

Ordering details

Drehzahl
Speed 540 min⁻¹

Bondioli & Pavesi **103-101-N-007-136**

Walterscheid **W2200-1010-SD15-20.10.00-K33B**